

ALLOY INSTALLATION

Panel	Dimensions (HxWxD)	Type
A	2440mm x 1220mm x 4mm	Square Edged Panel
B	2440mm x 900mm x 4mm	Square Edged Panel
C	2440mm x 600mm x 4mm	Square Edged Panel

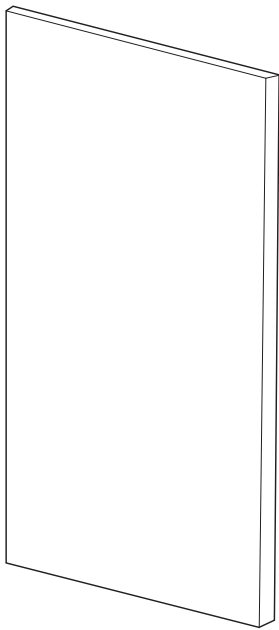

A

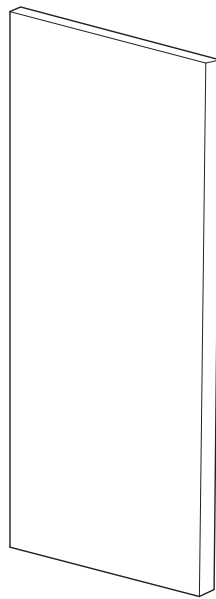

B

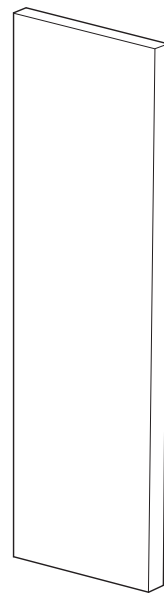

C

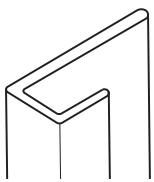

End Cap

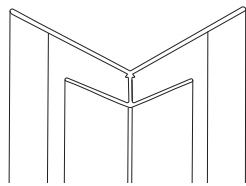

External Corner

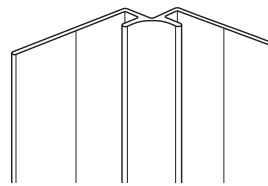

Internal Corner

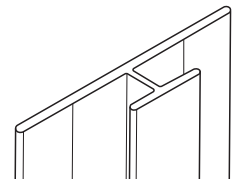

H-Joint

STORAGE



HANDLE
WITH CARE

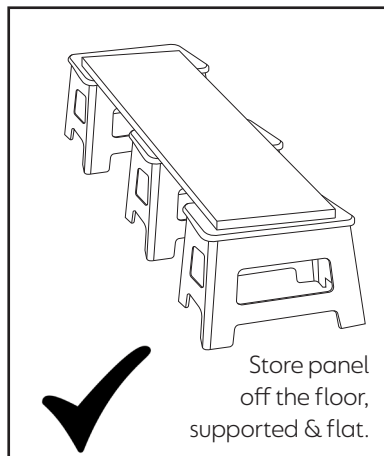
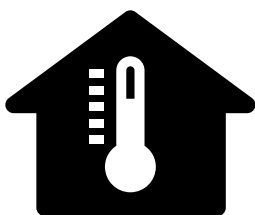

Store panel
off the floor,
supported & flat.

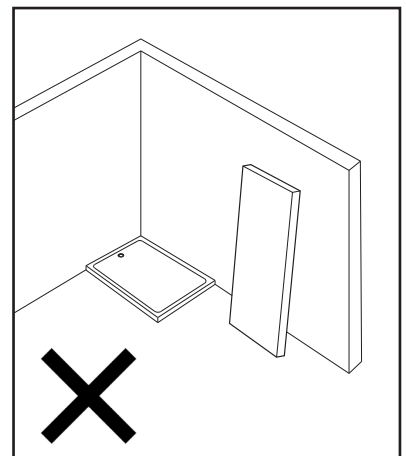

TOOLS

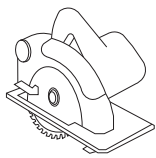

Circular Saw



Jig Saw

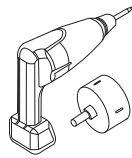

Drill

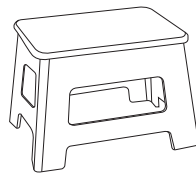

Stool/Tressle

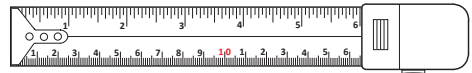
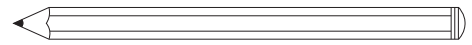

Measuring Tape & Spirit Level
Measuring Tape, Pencil & Spirit Level

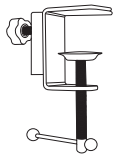

Clamp



Adhesive



Sealant

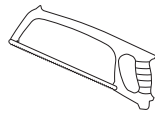

Hack Saw

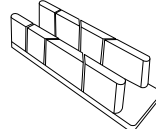

Cutting Block

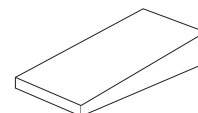

Spacers



Cleaning Wipes

SAFETY EQUIPMENT

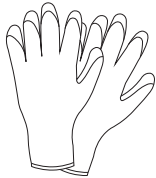

Gloves



Goggles



Boots



Dust Mask

Storage/Damages/Defects

Prior to installation condition all panels, adhesives and sealants to room temperature for at least 24 hours.

Always check for compatibility of colour and surface prior to installation as slight variations can occasionally occur. If a problem is identified, please contact your supplier immediately, who will be happy to deal with any issues. Once a panel is fitted or cut, it is deemed acceptance of product. Check the panels thoroughly for signs of damages or defects and NEVER begin installation until you are 100% happy. Claims for defects/damages can not be made after installation begins.

Installation Tips

- **We highly recommend performing a 'dry fit' of the install, for alignment purposes. Then remove the panels, clean the back with a damp clean cloth and allow to dry before undertaking the main install.**
- Panels must be thoroughly inspected upon receipt for damage or visible defects. The panels are supplied with a protective clear film to both the decorative face and the painted face, this should be peeled back to check for damage or discrepancies in colour where necessary then replaced to provide protection during installation. colour discrepancies should be checked from the face side only as the appearance of 'patching' on the rear face is normal during the painting. Some Alloy designs come double sided with different decors on each side these do not have a protective clear film.
- Use ONLY Wilsonart Complete adhesives and sealants to validate the Lifetime Guarantee.
- Wilsonart carry a Lifetime Guarantee; being whilst the original purchaser/homeowner owns the product and this is not transferable. Wilsonart will make good by repair and/or replacement (at its discretion) any Wilsonart product of its manufacture which can be shown to have failed by reason of defects in its manufacture, subject to fair wear and tear, provided the product has been installed and used in accordance with the manufacturer's instructions and that the products are used for their intended purpose/application. Proof of date and place of purchase is required. Installation to our guidelines and use of our sealants and adhesives are a condition of this guarantee.
- This guarantee is in addition to your statutory rights as a consumer and does not affect your rights in any way.
- Alloy panels can have extremely sharp edges and we advise that suitable gloves be worn for protection when handling and installing them. Extra care should be taken when handling, dry jointing and installing larger or shaped panels that have cut-outs in them as excessive flexing can cause cracking around the cut-outs.
- Position all joints vertically especially in wet areas.
- A 3mm - 4mm gap must be left between the bottom of the panel and top of the shower tray or bath, this can be achieved by using spacers when fixing panels. The gaps should then be sealed ensuring that the sealant is forced into the void.
- Fittings such as shower attachments, screens, towel rails, etc. can be fixed directly through the panels using suitable fixings. Heavy items will need solid fixing points behind the panels to provide the necessary support, these should be considered when planning your installation.
- When panels meet at the joints, remember designs are not intended to match across the joint. This is more obvious on large scale pattern/decors.
- Use white spirit and a clean wipe to remove excess adhesive.

WALL PREPARATION

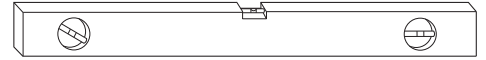

Ensure walls are level, dry, clean & damp free. Fixtures and Fittings **MUST** be secured to the wall behind the panel and pipework fed through. Panels must be fitted to a continuous surface such as plaster board, existing tiling, chipboard & plywood sheathing and tile backers providing the surface it is sound, plumb and level. Some surfaces do require pre-treatment before installation, tiles should be de-greased and fresh plaster should be sealed with a proprietary PVA sealer.

It is important to ensure that there are no areas of wall to be clad where there are distinct differences in shading such as tape lines in plaster boarding and grout lines in tiling as these can show through when installing lighter colours.

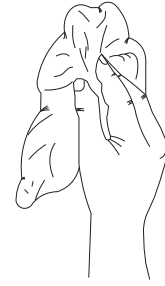

CUTTING THE PANELS

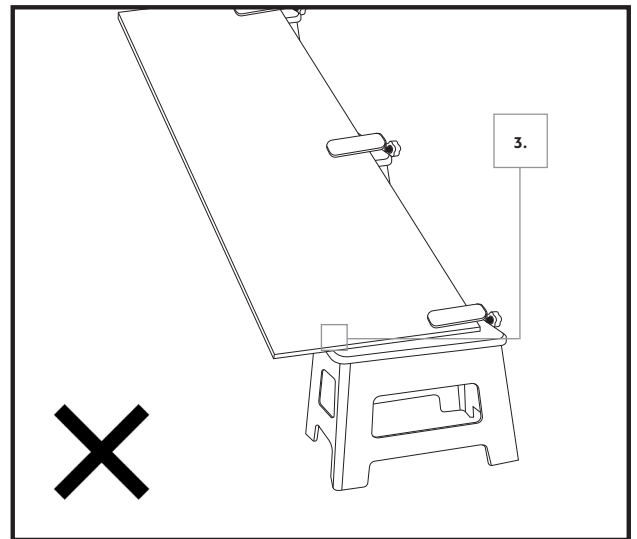
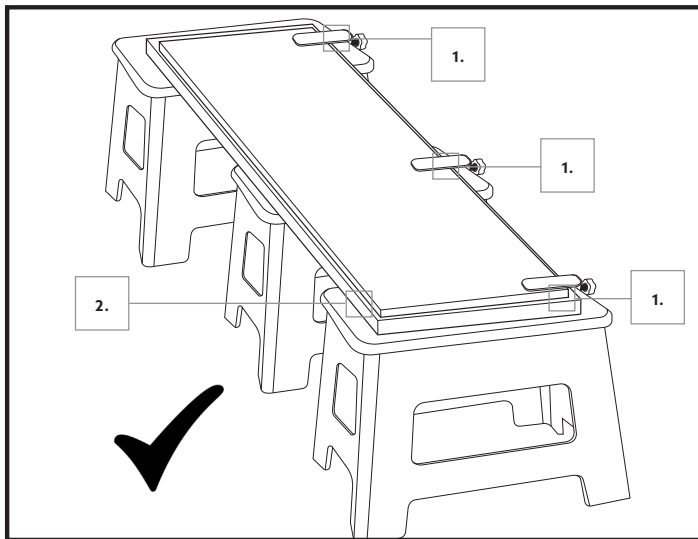

1. Fully Secure the panel

2. Cut into a supporting board (as the panel needs support due to it's thickness)

3. You can cut into the decorative face, or the reverse—either side is permissible.

Circular Saw

Tungsten Carbide Tipped (TCT) blades that are designed for metals or plastics should be used as these will be fine toothed and give the best finish, the following recommendations should be followed:

Jigsaw

Jigsaw blades that are specifically designed to cut aluminium should be used such as the Bosch T101A or Makita A-85721 B-21, if these are not available then a fine toothed blade such as those designed to cut metals should be used. A high speed should be selected and the rotary action switched off.

Drill Bit

HSS twist drills specifically made for metals and plastics can be used on Alloy panels. When drilling, a slow speed should be selected and the panel must be supported below.

Hole Saw

Hole saws can be used to cut the Alloy panels but must be the type designed to cut metal sheet. The panel must be supported from behind and clamped in position. Drill through the panel slowly. Edges of the hole should then be de-burred with 100 grit paper. Do not use a de-burring tool.

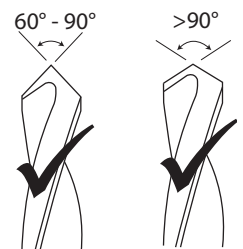

DRILLING THE PANELS

Drill bits specifically designed for aluminium should be used and TCT hole saws should be used at low speed and pressure. In both cases the Alloy must be flat, supported from underneath and secured in place with clamps.

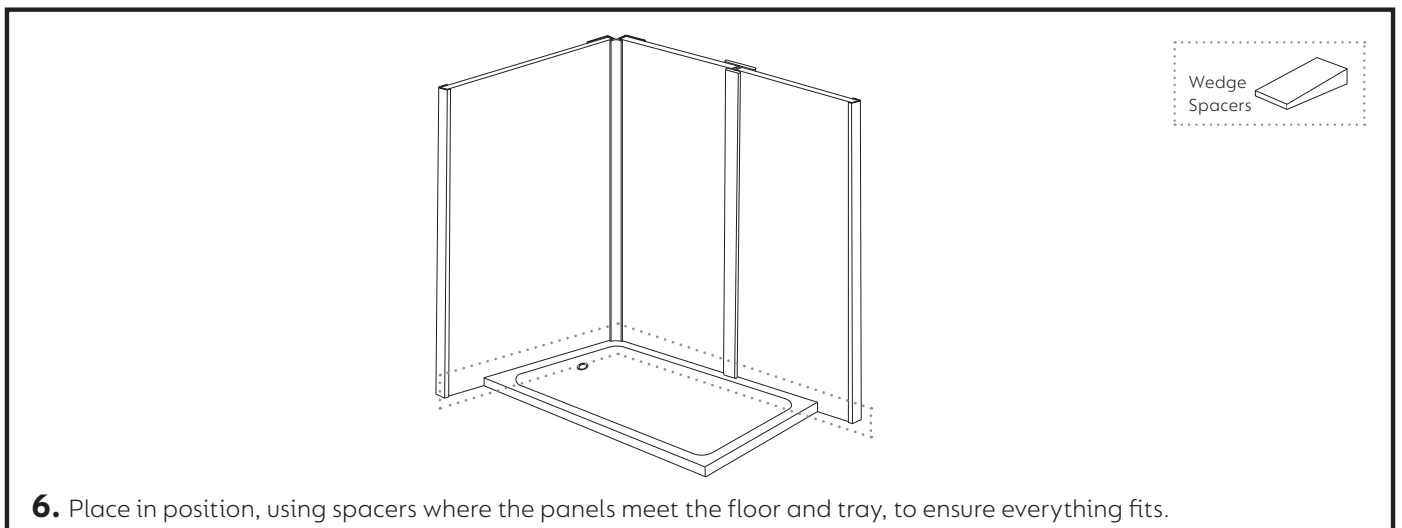
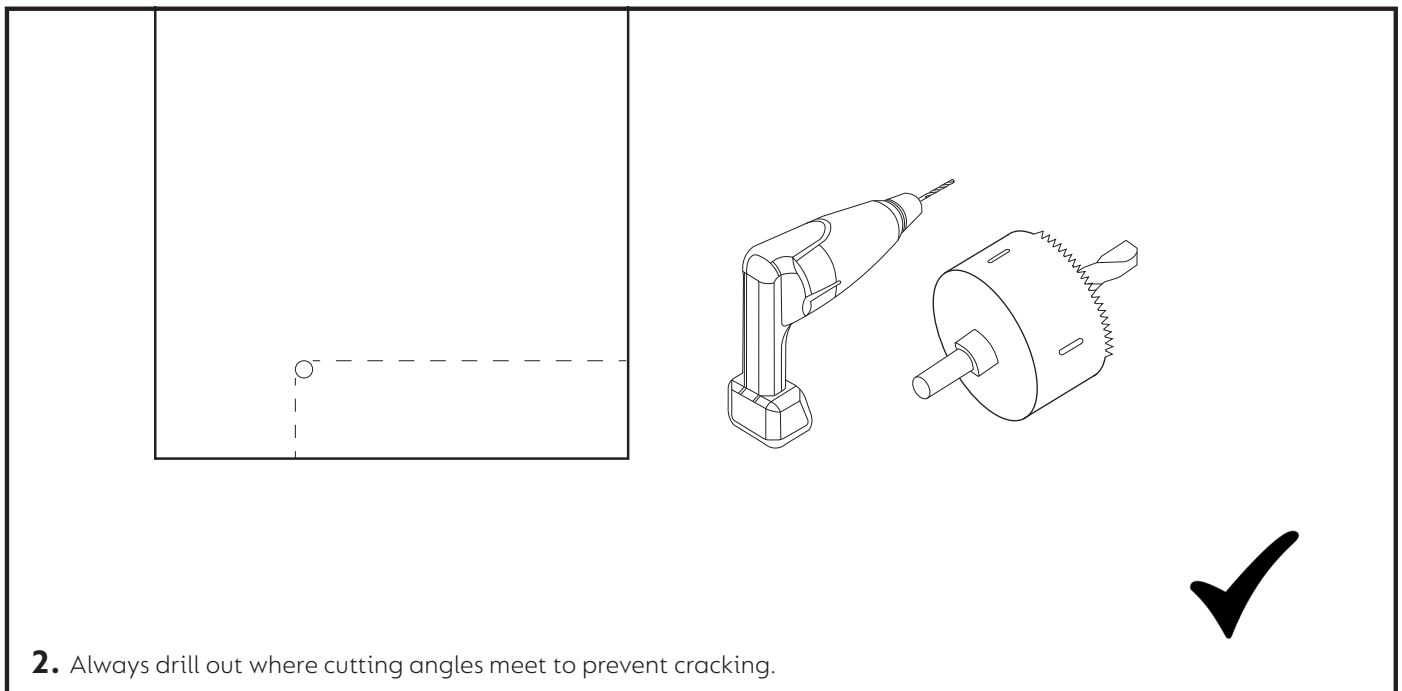
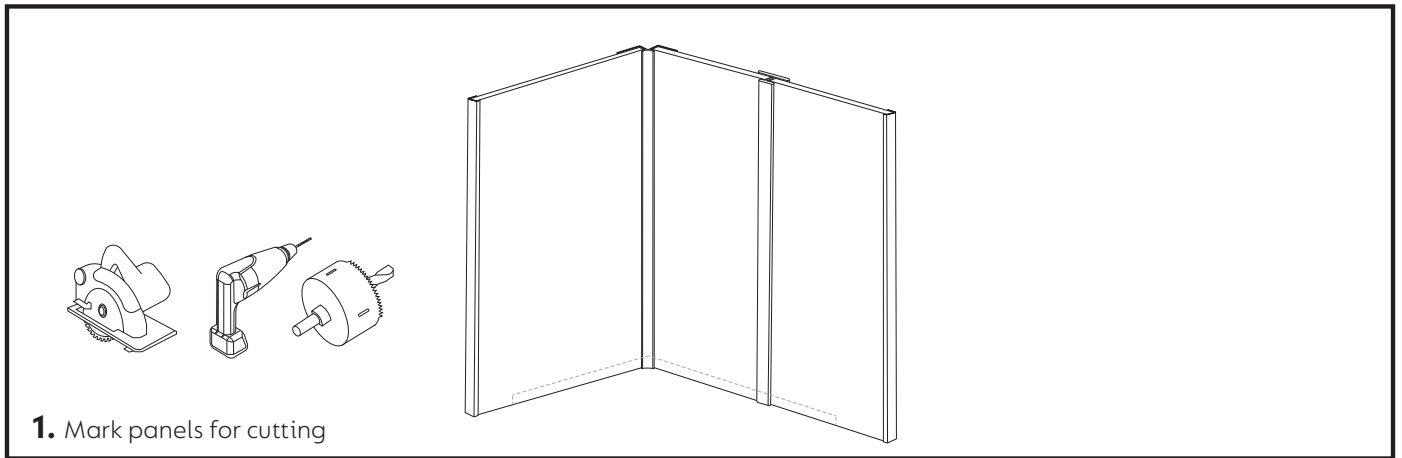

ADHESIVE APPLICATION

We highly recommend performing a **'dry fit'** of the install, for alignment purposes. Then remove the panels, clean the back with a damp clean cloth and allow to dry before undertaking the main install. Adhesive **MUST** be neutral cure.

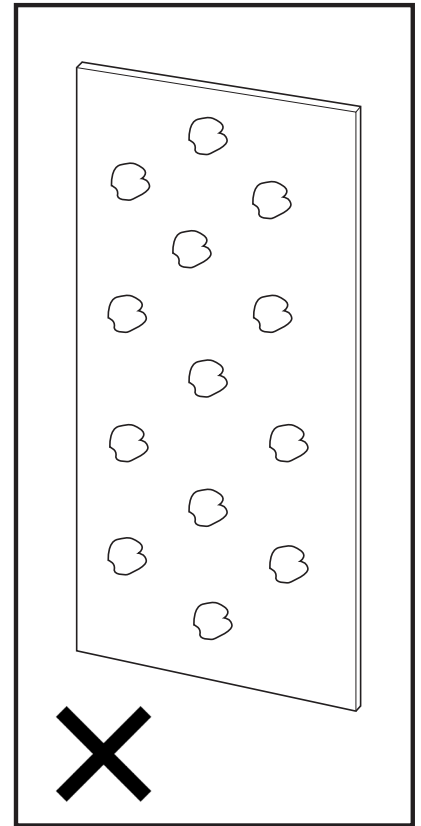
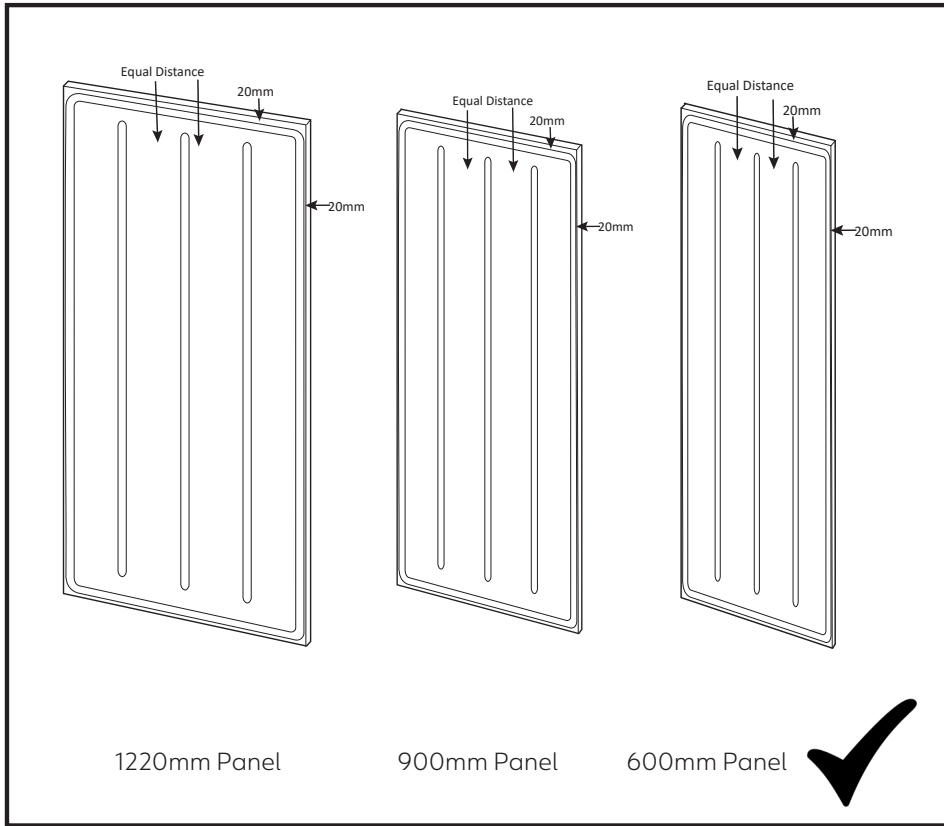

PANEL INSTALLATION

Apply adhesive before fitting each panel

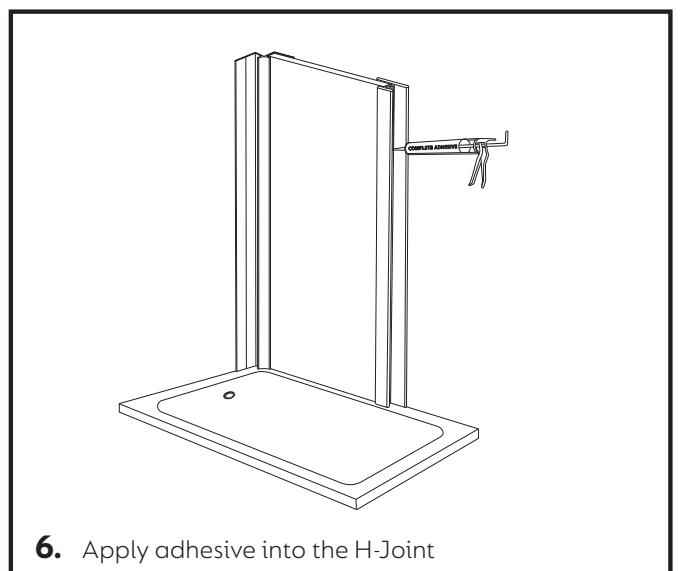
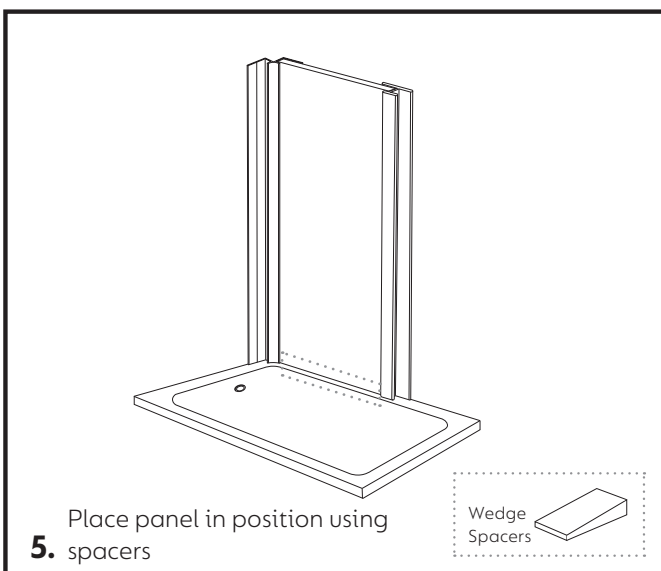
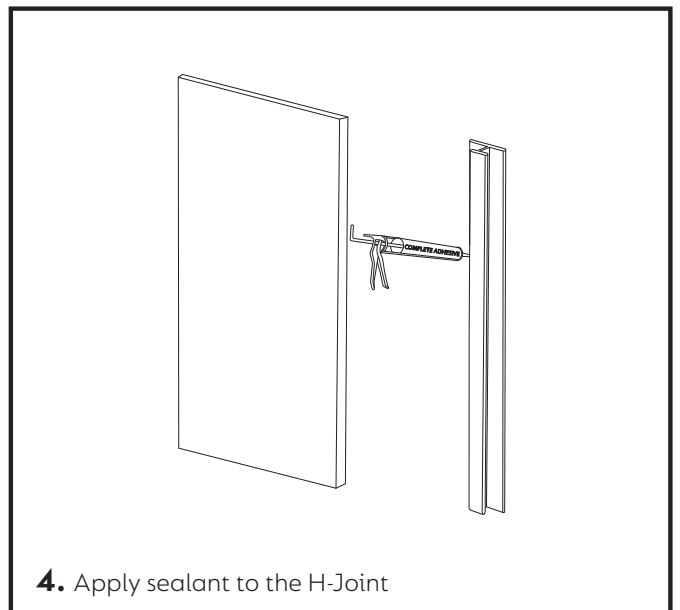
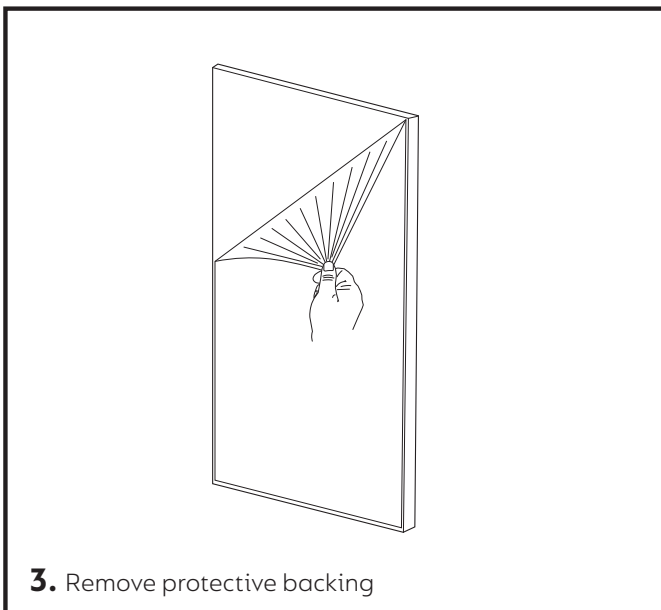
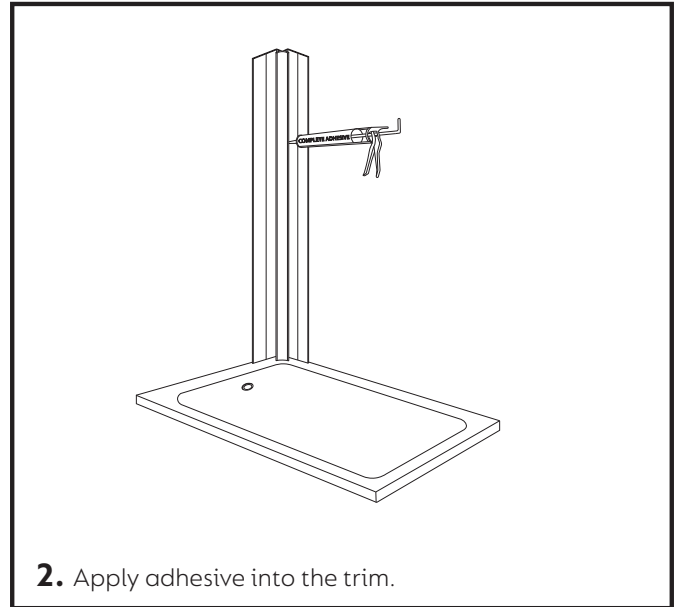
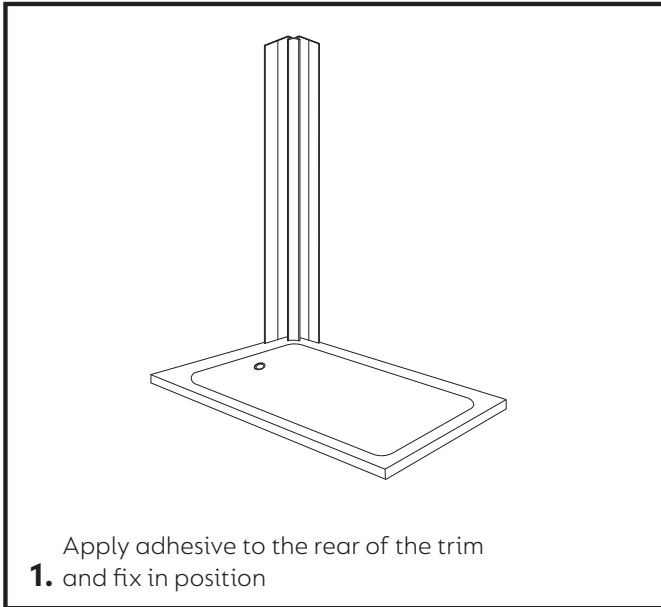

PANEL INSTALLATION

Apply adhesive before fitting each panel

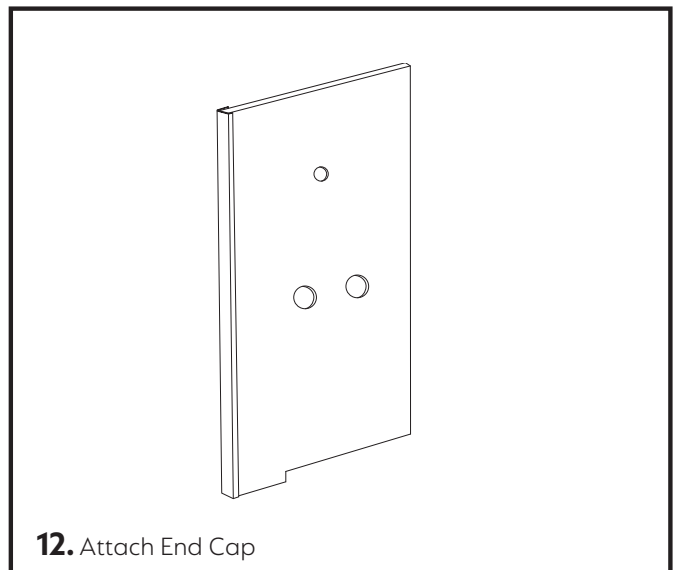
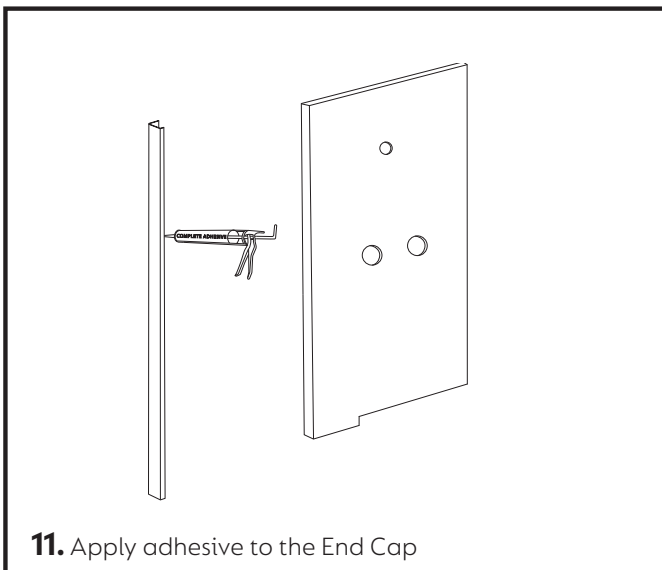
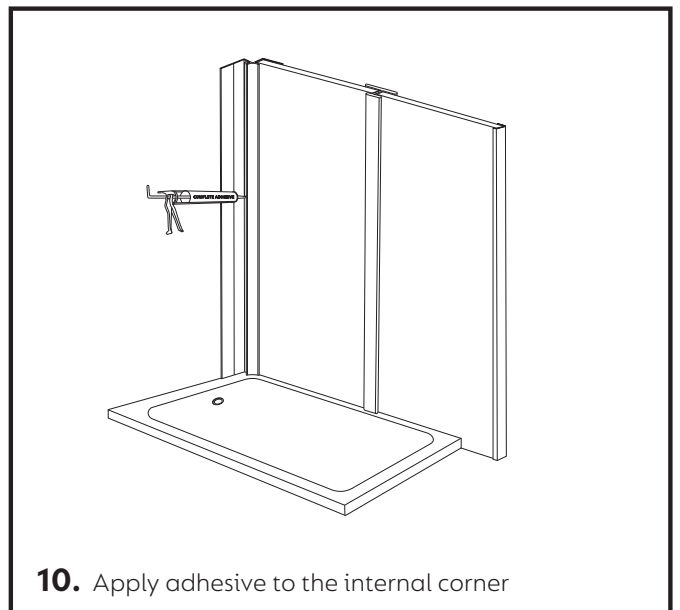
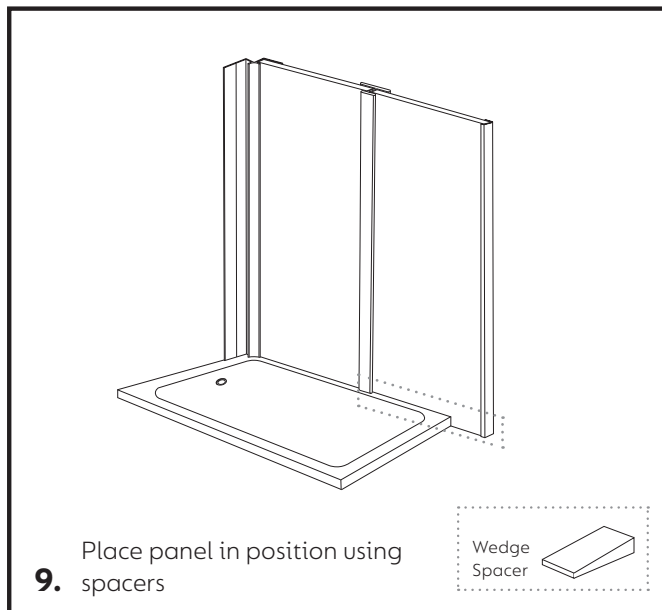
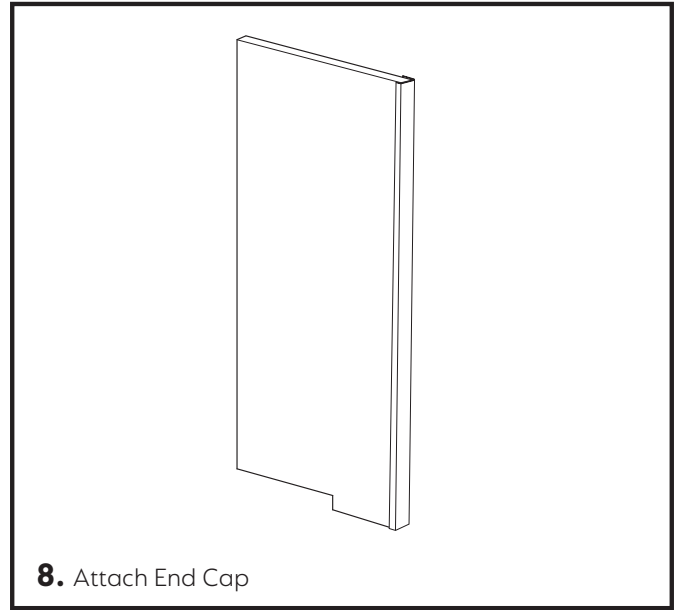
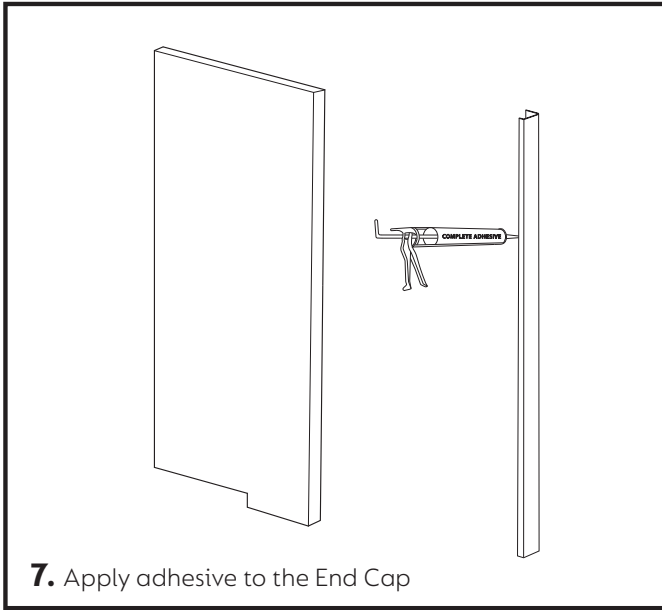

PANEL INSTALLATION

Apply adhesive before fitting each panel

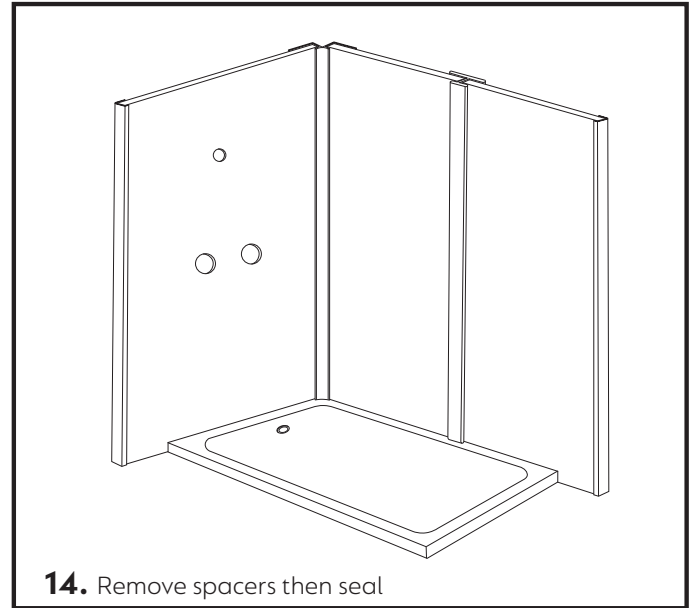
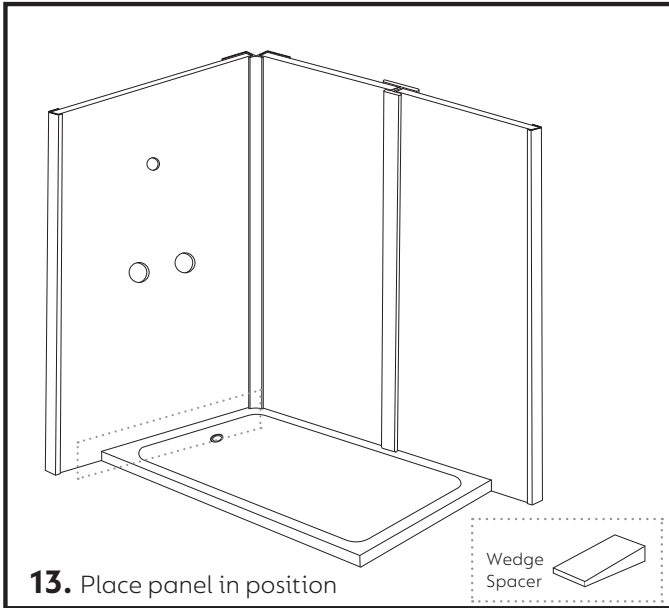

SEALING

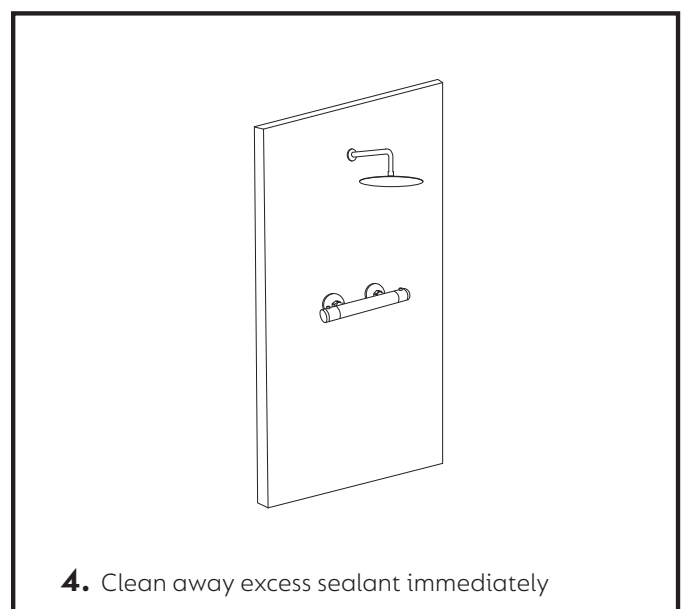
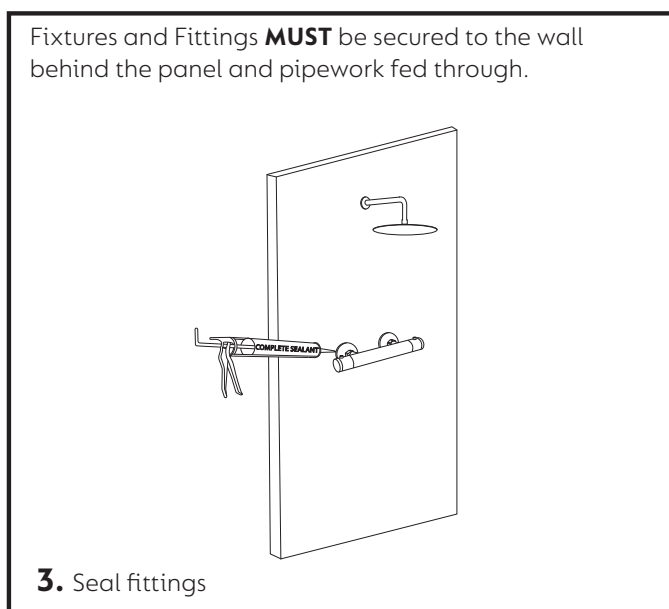
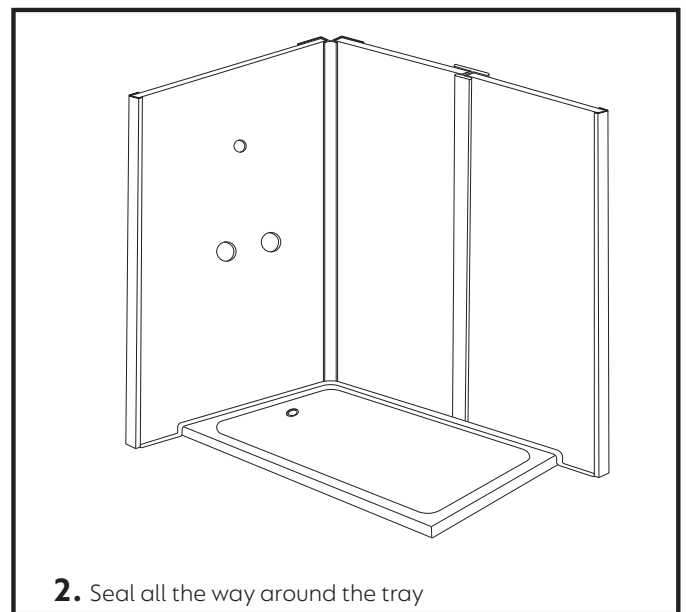
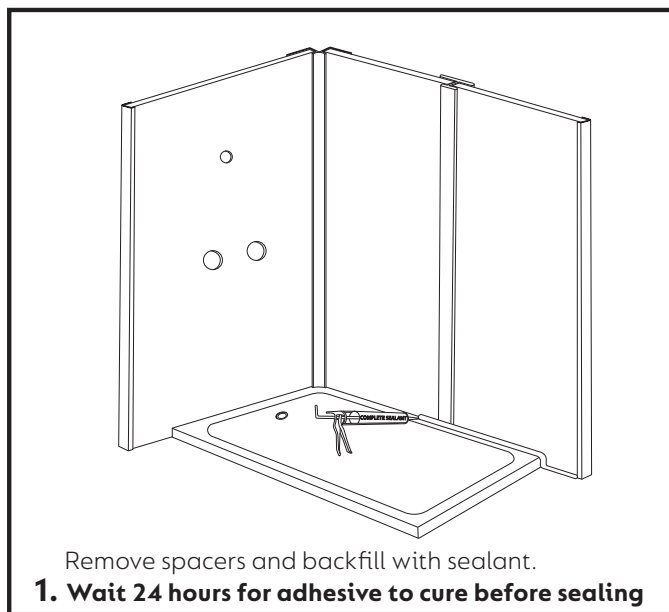

SEALING

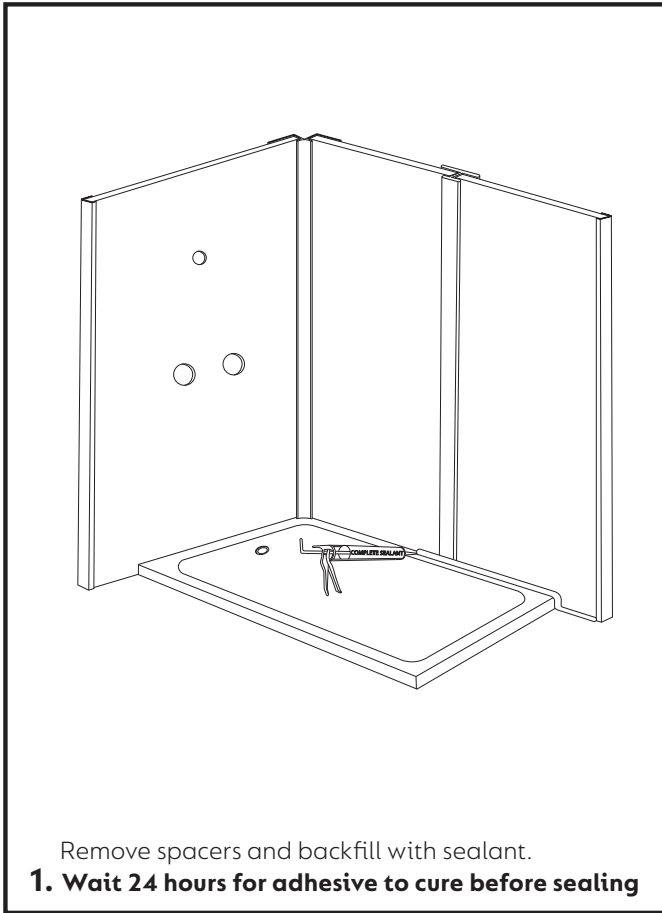

Remove spacers and backfill with sealant.
1. Wait 24 hours for adhesive to cure before sealing

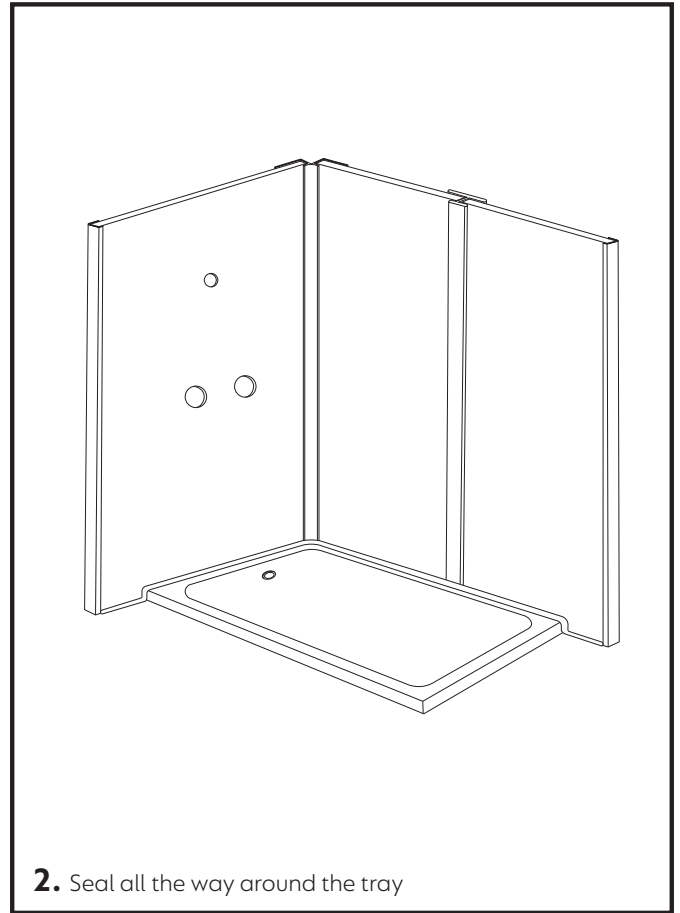

2. Seal all the way around the tray

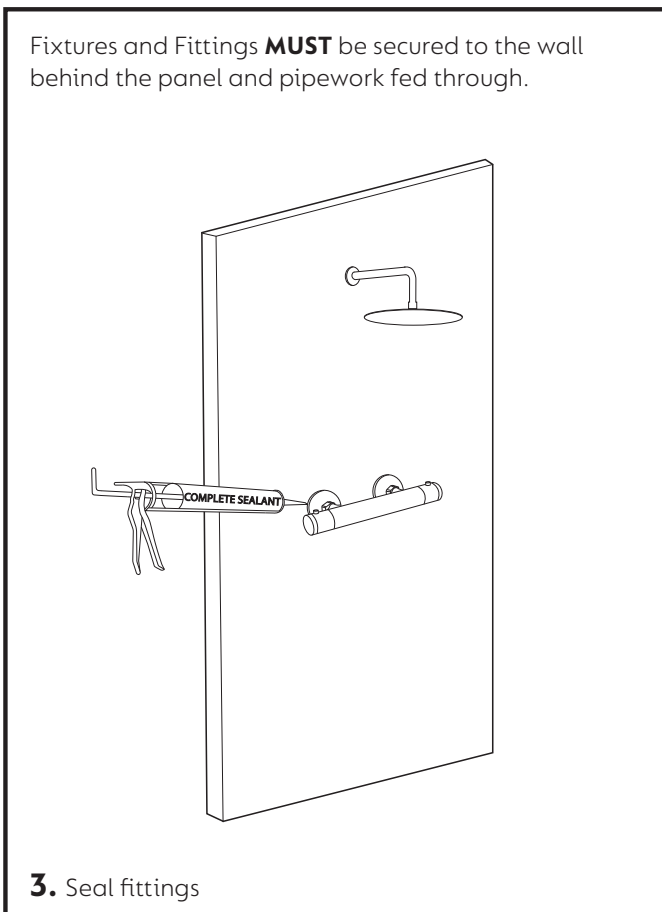

3. Seal fittings

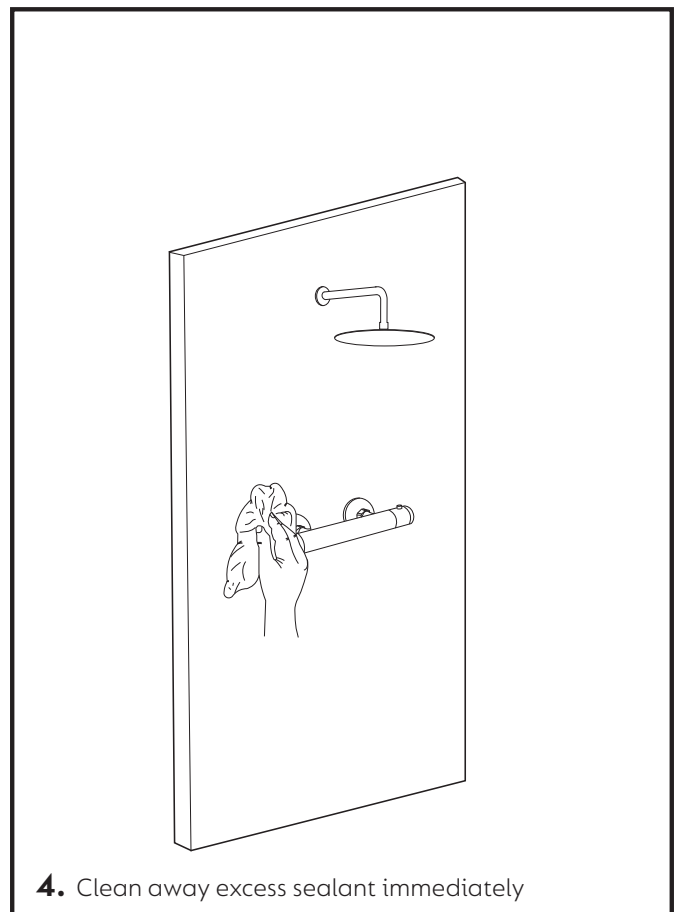

4. Clean away excess sealant immediately