



INSTRUCTIONS FOR
600W 230V
Mini Plunge Saw

Stock No.20979

Part No.MPS600

IMPORTANT: PLEASE READ THESE INSTRUCTIONS CAREFULLY TO ENSURE THE SAFE AND EFFECTIVE USE OF THIS PRODUCT.



DRAPER[®]

GENERAL INFORMATION

These instructions accompanying the product are the original instructions. This document is part of the product, keep it for the life of the product passing it on to any subsequent holder of the product. Read all these instructions before assembling, operating or maintaining this product.

This manual has been compiled by Draper Tools describing the purpose for which the product has been designed, and contains all the necessary information to ensure its correct and safe use. By following all the general safety instructions contained in this manual, it will ensure both product and operator safety, together with longer life of the product itself.

All photographs and drawings in this manual are supplied by Draper Tools to help illustrate the operation of the product.

Whilst every effort has been made to ensure the accuracy of information contained in this manual, the Draper Tools policy of continuous improvement determines the right to make modifications without prior warning.

1. TITLE PAGE

1.1 INTRODUCTION:

USER MANUAL FOR:

600W 230V MINI PLUNGE SAW

Stock no. 20979

Part no. MPS600

1.2 REVISIONS:

Date first published August 2016

Date first revised September 2016

As our user manuals are continually updated, users should make sure that they use the very latest version.

Downloads are available from: <http://www.drapertools.com/manuals>

DRAPER TOOLS LIMITED

HURSLEY ROAD

CHANDLER'S FORD

EASTLEIGH

HAMPSHIRE

SO53 1YF

UK

WEBSITE: drapertools.com

PRODUCT HELP LINE: +44 (0) 23 8049 4344

GENERAL FAX: +44 (0) 23 8026 0784

1.3 UNDERSTANDING THIS MANUALS SAFETY CONTENT:

WARNING! Information that draws attention to the risk of injury or death.

CAUTION! Information that draws attention to the risk of damage to the product or surroundings.

1.4 COPYRIGHT © NOTICE:

Copyright © Draper Tools Limited.

Permission is granted to reproduce this publication for personal & educational use only.

Commercial copying, redistribution, hiring or lending is prohibited.

No part of this publication may be stored in a retrieval system or transmitted in any other form or means without written permission from Draper Tools Limited.

In all cases this copyright notice must remain intact.

2. CONTENTS

2.1 CONTENTS

	<i>Page content</i>	<i>Page</i>
1	TITLE PAGE	
	1.1 INTRODUCTION	2
	1.2 REVISION HISTORY	2
	1.3 UNDERSTANDING THIS MANUAL	2
	1.4 COPYRIGHT NOTICE	2
2	CONTENTS	
	2.1 CONTENTS	3
3	GUARANTEE	
	3.1 GUARANTEE	4
4	INTRODUCTION	
	4.1 SCOPE	5
	4.2 SPECIFICATION	5
	4.3 HANDLING & STORAGE	5
5	HEALTH & SAFETY INFORMATION	
	5.1 GENERAL SAFETY INSTRUCTIONS FOR POWER TOOL USE	6 - 7
	5.2 ADDITIONAL SAFETY INSTRUCTIONS FOR ALL SAWS	7 - 8
	5.3 PENDULUM GUARDS	8 - 9
	5.4 ADDITIONAL SAFETY INSTRUCTIONS FOR MINI CIRCULAR SAW BLADES	9 - 10
	5.5 ADDITIONAL SAFETY INSTRUCTIONS FOR LASER PRODUCTS	10
	5.6 CONNECTION TO THE POWER SUPPLY	10
6	TECHNICAL DESCRIPTION	
	6.1 IDENTIFICATION	11
7	UNPACKING & CHECKING	
	7.1 PACKAGING	12
	7.2 WHAT'S IN THE BOX	12
8	ASSEMBLING THE MINI PLUNGE SAW	
	8.1 SETTING THE CUTTING DEPTH	13
	8.2 CHANGING THE SAW BLADE	13
9	OPERATING THE MINI PLUNGE SAW	
	9.1 SWITCHING ON THE PLUNGE SAW	14
	9.2 RELEASING THE PLUNGE STOP	14
	9.3 SETTING THE GUIDE FENCE	14
	9.4 LASER LINE GENERATOR	15
	9.5 LINE FOLLOWING	15
	9.6 DUST EXTRACTION	16
	9.7 CUTTING	17
	9.8 CUT-OUTS	18
	9.9 CUTTING TOUGH OR ABRASIVE MATERIALS	19
10	MAINTENANCE	
	10.1 MAINTENANCE	20
11	TROUBLESHOOTING	21
12	EXPLANATION OF SYMBOLS	
	12.1 EXPLANATION OF SYMBOLS	22
13	DISPOSAL	
	13.1 DISPOSAL	23
	DECLARATION OF CONFORMITY	ENCLOSED

3. GUARANTEE

3.1 GUARANTEE

Draper tools have been carefully tested and inspected before shipment and are guaranteed to be free from defective materials and workmanship.

Should the tool develop a fault, please return the complete tool to your nearest distributor or contact Draper Tools Limited, Chandler's Ford, Eastleigh, Hampshire, SO53 1YF. England.

Telephone Sales Desk: (023) 8049 4333 or Product Help Line (023) 8049 4344.

A proof of purchase must be provided with the tool.

If upon inspection it is found that the fault occurring is due to defective materials or workmanship, repairs will be carried out free of charge. This guarantee period covering parts/labour is 12 months from the date of purchase except where tools are hired out when the guarantee period is 90 days from the date of purchase. The guarantee is extended to 24 months for parts only. This guarantee does not apply to normal wear and tear, nor does it cover any damage caused by misuse, careless or unsafe handling, alterations, accidents, or repairs attempted or made by any personnel other than the authorised Draper warranty repair agent.

Note: If the tool is found not to be within the terms of warranty, repairs and carriage charges will be quoted and made accordingly.

This guarantee applies in lieu of any other guarantee expressed or implied and variations of its terms are not authorised.

Your Draper guarantee is not effective unless you can produce upon request a dated receipt or invoice to verify your proof of purchase within the guarantee period.

Please note that this guarantee is an additional benefit and does not affect your statutory rights.

Draper Tools Limited.

4. INTRODUCTION

4.1 SCOPE

Suitable for the sawing of solid wood, chipboard, plywood, aluminium, tiles and stone that are secured in a fixed position. It is intended for domestic and light commercial use only. Any other application is considered misuse.

NOTE: The blade initially installed within the plunge saw is intended for use with wood only.

4.2 SPECIFICATION

Stock No.....	20979
Part No.....	MPS600
Rated voltage	230V~50Hz
Rated input	600W
Saw blade:	
Diameter.....	89mm
Bore Ø.....	10mm
Maximum depth of cut 90°	28.5mm
Aluminium.....	3mm
Tile	8mm
Wood	28.5mm
Revolutions per minute (no load)	5,500min ⁻¹
Laser:	
Type.....	Class 2
Output power.....	1mW
Wavelength	650nm
Batteries.....	2 x 1.5V LR44 Button cells
Sound pressure level	93.78dB(A)
Sound power level	104.78dB(A)
Vibration level.....	3.356m/s ²
Weight (machine only)	2.3kg

4.3 HANDLING & STORAGE

Although this machine is small in size, care must still be taken when handling and lifting. Dropping this machine will have an effect on the accuracy and may also result in personal injury. This machine is not a toy and must be respected.

The environment will have a negative result on its operation if you are not careful. If the air is damp, components will rust. If the machine is unprotected from dust and debris; components will become clogged: And if not cleaned and maintained correctly or regularly the machine will not perform at its best.

5. HEALTH & SAFETY INFORMATION

5.1 GENERAL SAFETY INSTRUCTIONS

General Power Tools Safety Warnings

WARNING: Read all instructions. Failure to follow all instructions listed below may result in electric shock, fire and/or serious injury.

Save all warnings and instructions for future reference.

The term “power tool” in the warnings refers to your mains operated (corded) power tool or battery operated (cordless) power tool.

1) Work area safety

- a) **Keep work area clean and well lit.** Cluttered or dark areas invite accidents.
- b) **Do not operate power tools in explosive atmospheres, such as in the presence of flammable liquids, gases or dust.** Power tools create sparks which may ignite the dust or fumes.
- c) **Keep children and bystanders away while operating a power tool.** Distractions can cause you to lose control.

2) Electrical Safety

- a) **Power tool plugs must match the outlet.** Never modify the plug in any way. Do not use any adapter plugs with earthed (grounded) power tools. Unmodified plugs and matching outlets will reduce risk of electrical shock.
- b) **Avoid body contact with earthed or grounded surfaces such as pipes, radiators, ranges and refrigerators.** There is an increased risk of electric shock if your body is earthed or grounded.
- c) **Do not expose power tools to rain or wet conditions.** Water entering a power tool will increase the risk of electric shock.
- d) **Do not abuse the cord. Never use the cord for carrying, pulling or unplugging the power tool.** Keep cord away from heat, oil, sharp edges or moving parts. Damaged or entangled cords increase the risk of electric shock.
- e) **When operating a power tool outdoors, use an extension cord suitable for outdoor use.** Use of a cord suitable for outdoor use reduces the risk of electric shock.
- f) **If operating a power tool in a damp location is unavoidable, use a residual current device (RCD) protected supply.** Use of an RCD reduces the risk of electric shock.

3) Personal Safety

- a) **Stay alert, watch what you are doing and use common sense when operating a power tool. Do not use a power tool while you are tired or under the influence of drugs, alcohol or medication.** A moment of inattention while operating power tools may result in serious personal injury.
- b) **Use personal protective equipment. Always wear eye protection.** Protective equipment such as dust mask, nonskid safety shoes, hard hat, or hearing protection used for appropriate conditions will reduce personal injuries.
- c) **Prevent unintentional starting. Ensure the switch is in the off position before connecting to power source and/or battery pack, picking up or carrying the tool.** Carrying power tools with your finger on the switch or energising power tools that have the switch on invites accidents.
- d) **Remove any adjusting key or wrench before turning the power tool on.** A wrench or a key left attached to a rotating part of the power tool may result in personal injury.
- e) **Do not overreach. Keep proper footing and balance at all times.** This enables better control of the power tool in unexpected situations.
- f) **Dress properly. Do not wear loose clothing or jewellery. Keep your hair, clothing and gloves away from moving parts.** Loose clothes, jewellery or long hair can be caught in moving parts.

5. HEALTH & SAFETY INFORMATION

- g) If devices are provided for the connection of dust extraction and collection facilities, ensure these are connected and properly used. Use of dust collection can reduce dust related hazards.
- 4) **Power Tool Use And Care**
- a) **Do not force the power tool. Use the correct power tool for your application.** The correct power tool will do the job better and safer at the rate for which it was designed.
- b) **Do not use the power tool if the switch does not turn it on and off.** Any power tool that cannot be controlled with the switch is dangerous and must be repaired.
- c) **Disconnect the plug from the power source and/or the battery pack from the power tool before making any adjustments, changing accessories, or storing power tools.** Such preventive safety measures reduce the risk of starting the power tool accidentally.
- d) **Store idle power tools out of the reach of children and do not allow persons unfamiliar with the power tool or these instructions to operate the power tool.** Power tools are dangerous in the hands of untrained users.
- e) **Maintain power tools. Check for misalignment or binding of moving parts, breakage of parts and any other condition that may affect the power tools operation. If damaged, have the power tool repaired before use.** Many accidents are caused by poorly maintained power tools.
- f) **Keep cutting tools sharp and clean.** Properly maintained cutting tools with sharp cutting edges are less likely to bind and are easier to control.
- g) **Use the power tool, accessories and tool bits etc., in accordance with these instructions, taking into account the working conditions and the work to be performed.** Use of the power tool for operations different from intended could result in a hazardous situation.
- 5) **Service**
- a. **Have your power tool serviced by a qualified repair person using only identical replacement parts.** This will ensure that the safety of the power tool is maintained.

5.2 **ADDITIONAL SAFETY INSTRUCTIONS FOR ALL SAWS**

DANGER:

- a) Keep hands away from cutting area and the blade. Keep your second hand on the auxiliary handle, or motor housing. If both hands are holding the saw, they cannot be cut by the blade.
- b) Do not reach underneath the workpiece. The guard cannot protect you from the blade below the workpiece.
- c) Adjust the cutting depth to the thickness of the workpiece. Less than a full tooth of the blade teeth should be visible below the workpiece.
- d) Never hold piece being cut in your hands or across your leg. Secure the workpiece to a stable platform. It is important to support the work properly to minimise body exposure, blade binding or loss of control.
- e) Hold power tool by insulated gripping surfaces when performing an operation where the cutting tool may contact hidden wiring or its own cord. Contact with a "live" wire will also make exposed metal parts of the power tool "live" and shock the operator.
- f) When ripping always use a rip fence or straight edge guide. This improves the accuracy of cut and reduces chance of blade binding.

- g) Always use blade with correct size and shape (diamond versus round) of arbour holes. Blades that do not match the mounting hardware of the saw will run eccentrically, causing loss of control.
- h) Never use damaged or incorrect blade washers or bolt. The blade washers and bolt were specially designed for your saw, for optimum performance and safety of operation.

Causes and operator prevention of kickback:

- kickback is a sudden reaction to a pinched, bound or misaligned saw blade, causing an uncontrolled saw to lift up and out of the workpiece towards the operator.
- when the blade is pinched or bound tightly by the kerf closing down, the blade stalls and the motor reaction drives the unit rapidly back towards the operator.
- if the blade becomes twisted or misaligned in the cut, the teeth at the back edge of the blade can dig into the top surface of the wood causing the blade to climb out of the kerf and jump back toward the operator.

Kickback is the result of saw misuse and/or incorrect operating procedures or conditions and can be avoided by taking proper precautions as given below.

- a) Maintain a firm grip with both hands on the saw and position your arms to resist kickback forces. Position your body to either side of the blade, but not in line with the blade. Kickback could cause the saw to jump backwards, but kickback forces can be controlled by the operator, if proper precautions are taken.
- b) When blade is binding, or when interrupting a cut for any reason, release the trigger and hold the saw motionless in the material until the blade comes to a complete stop. Never attempt to remove the saw from the work or pull the saw backward while the blade is in motion or kickback may occur. Investigate and take corrective actions to eliminate the cause of blade binding.
- c) When restarting a saw in the workpiece, centre the saw blade in the kerf and check that saw teeth are not engaged into the material. If saw blade is binding, it may walk up or kickback from the workpiece as the saw is restarted.
- d) Support large panels to minimise the risk of blade pinching and kickback. Large panels tend to sag under their own weight. Supports must be placed under the panel on both sides, near the line of cut and near the edge of the panel.
- e) Do not use dull or damaged blades. Unsharpened or improperly set blades produce narrow kerf causing excessive friction, blade binding and kickback.
- f) Blade depth and bevel adjusting locking levers must be tight and secure before making cut. If blade adjustment shifts while cutting, it may cause binding and kickback.
- g) Use extra caution when making a "plunge cut" into existing walls or other blind areas. The protruding blade may cut objects that can cause kickback.

5.3 PENDULUM GUARDS

- a) Check lower guard for proper closing before each use. Do not operate the saw if lower guard does not move freely and close instantly. Never clamp or tie the lower guard into the open position. If saw is accidentally dropped, lower guard may be bent. Raise the lower guard with the retracting handle and make sure it moves freely and does not touch the blade or any other part, in all angles and depths of cut.
- b) Check the operation of the lower guard spring. If the guard and spring are not operating properly, they must be serviced before use. Lower guard may operate sluggishly due to damaged parts, gummy deposits, or a build up of debris.
- c) Lower guard should be retracted manually only for special cuts such as "plunge cuts" and "compound cuts". Raise lower guard by retracting handle and as soon as the blade enters the material, the lower guard must be released. For all other sawing, the lower guard should operate automatically.

5. HEALTH & SAFETY INFORMATION

- d) Always observe that the lower guard is covering the blade before placing saw down on bench or floor. An unprotected, coasting blade will cause the saw to walk backwards, cutting whatever is in its path. Be aware of the time it takes for the blade to stop after the switch is released.

5.4 ADDITIONAL SAFETY INSTRUCTIONS FOR MINI CIRCULAR SAW BLADES

Safe Working Practice

Maximum speed

- The maximum speed marked on the tool shall not be exceeded. Where stated, the speed range shall be adhered to.

Circular saw blades

- Circular saw blades, the bodies of which are cracked, shall be scrapped (repairing is not permitted).
- Composite (tipped) circular saw blades, where the tip dimension is reduced to less than 1mm, shall be taken out of service.

One piece tools

- Clamping screws shall be tightened according to instructions provided by the manufacturer. Where instructions are not provided, clamping screws shall be tightened in sequence from the centre outwards.
- Use of loose rings or bushes to "make up" bore sizes on circular saw blades shall not be permitted.
- Use of fixed rings, e.g. pressed or held by adhesive fixing, in circular saw blades or flanged bushes for other tools shall be permitted if made to the manufacturers specification.
- Resin shall only be removed from light alloys with solvents that do not affect the mechanical characteristics of these materials.

Repair of tools

- Repair of tools is only allowed according to the tool manufacturers instructions. Particular attention is drawn to the following.
- The design of composite (tipped) tools shall not be changed in the process of repair.
- Composite tools shall be repaired by a competent person, i.e. a person of training and experience, who has knowledge of the design requirements and understands the levels of safety to be achieved.

5. HEALTH & SAFETY INFORMATION

- Repair shall therefore include, e.g. use of spare parts which are in accordance with the specification of the original parts provided by the manufacturer.
- Tolerances which ensure correct clamping shall be maintained.
- For one piece tools care shall be taken that regrinding of the cutting edge will not cause weakening of the hub and the connection of the cutting edge to the hub.

5.5 ADDITIONAL SAFETY INSTRUCTIONS FOR LASER PRODUCTS

- Laser radiation. Do NOT stare into beam. Class 2 laser product.
- Viewing the laser output with certain optical instruments (for example, eye loupes, magnifiers and microscopes) with a distance of 100mm may pose an eye hazard.
- Viewing the laser output with certain optical instruments designed for use at a distance (for example, telescopes and binoculars) may pose an eye hazard.
- CAUTION: Use of controls or adjustments or performance of procedures other than those specified herein may result in hazardous radiation exposure.
- Do NOT direct the beam towards a person's eyes.
- Avoid positioning the laser such that it may lead to unintentional eye exposure to any potential passing pedestrians/traffic.
- Do NOT direct the beam towards animals.
- Do NOT use in the vicinity of children.
- Do NOT direct the beam onto reflective surfaces.
- Always switch off when not in use and do not leave unattended. Remove the batteries before storing the Mini Plunge Saw away.
- This laser product has no serviceable parts. Do not attempt to disassemble or repair.

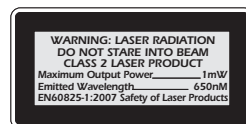

NOTE: Laser is powered by 2 x 1.5V LR44 button cells. Access to these, should they need to be replaced is achieved by removing the plastic laser housing after removing the screw that holds it in place.

5.6 CONNECTION TO THE POWER SUPPLY

Make sure the power supply information on the machine's rating plate are compatible with the power supply you intend to connect it to.

This product comes supplied with a UK standard 3 pin plug fitted. It is designed for connection to a domestic power supply rated at 230V AC.

This appliance is Class II† and is designed for connection to a power supply matching that detailed on the rating label and compatible with the plug fitted.

If an extension lead is required, use an approved and compatible lead rated for this appliance. Follow all the instruction supplied with the extension lead.

†Double insulated : This product requires no earth connection as supplementary insulation is applied to the basic insulation to protect against electric shock in the event of failure of the basic insulation.

Apart from replacing the fuse in the plug, no other electrical work is recommended on this machine.

6. TECHNICAL DESCRIPTION

6.1 IDENTIFICATION

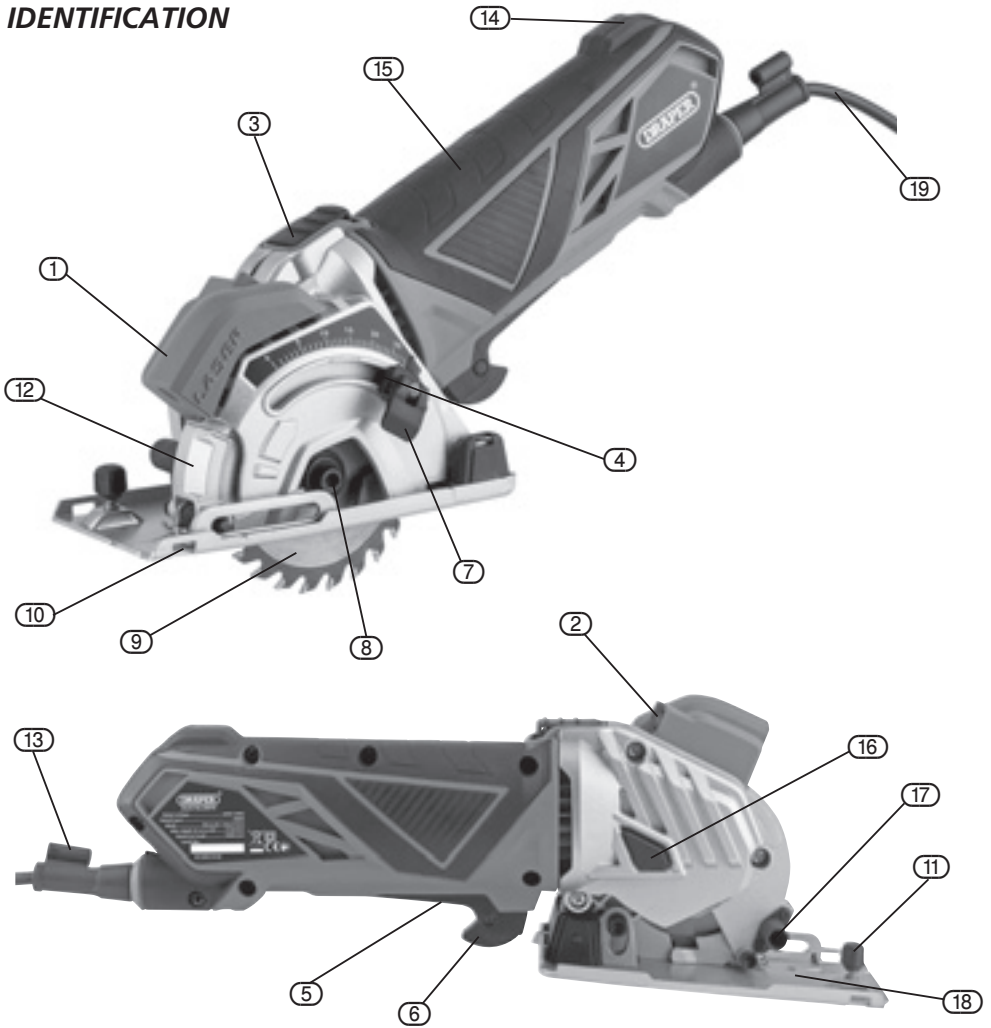

- ① Laser beam aperture
- ② Laser On/off switch
- ③ Safety lock button
- ④ Cutting depth gauge
- ⑤ ON/OFF switch trigger
- ⑥ Lock-off button
- ⑦ Cutting depth adjustment & lock.
- ⑧ Saw blade locking flange bolt
- ⑨ Saw blade
- ⑩ Parallel guide slot

- ⑪ Parallel guide locking screw
- ⑫ Removable protecting cover
- ⑬ Hex key holder
- ⑭ LED power indicator
- ⑮ Handle
- ⑯ Spindle lock button
- ⑰ Dust extraction outlet
- ⑱ Base plate
- ⑲ Power cable

7. UNPACKING & CHECKING

7.1 PACKAGING

Carefully remove the plunge saw from the packaging and examine it for any sign of damage that may have happened during shipping. Lay the contents out and check them against the parts shown below. If any part is damaged or missing; please contact the Draper Help Line (the telephone number appears on the Title page) and do not attempt to use the plunge saw.

The packaging material should be retained at least during the guarantee period: in case the machine needs to be returned for repair.

Warning! Some of the packaging materials used may be harmful to children. Do not leave any of these materials in the reach of children.

If any of the packaging is to be thrown away, make sure they are disposed of correctly; according to local regulations.

7.2 WHAT'S IN THE BOX?

As well as the plunge saw; there are several parts not fitted or attached to it.

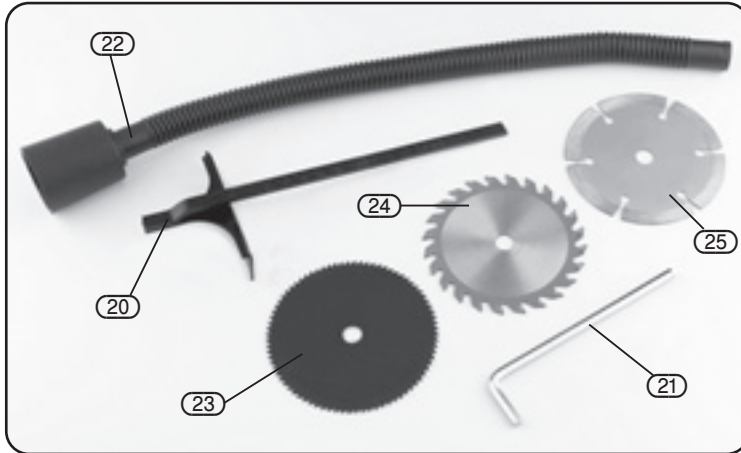

- (20) Parallel guide
- (21) Hex. key
- (22) Dust extraction hose
- (23) HSS saw blade for brass, copper, lead, aluminium
- (24) TCT blade for softwood, hardwood, boards of all types
- (25) Diamond saw blade for ceramics, tiles, slate

8. ASSEMBLING THE MINI PLUNGE SAW

NOTE: Remove the plug from the socket before carrying out adjustment, servicing or maintenance.

WARNING: It is recommended that the cutting depth is set approximately 2mm deeper than the thickness of the material that is being cut. This should ensure a cleaner cut.

8.1 SETTING THE CUTTING DEPTH - FIG. 1

Release the locking lever of the cutting depth adjustment (7), set to the required cutting depth via the cutting depth gauge (4) and re-clamp the locking lever.

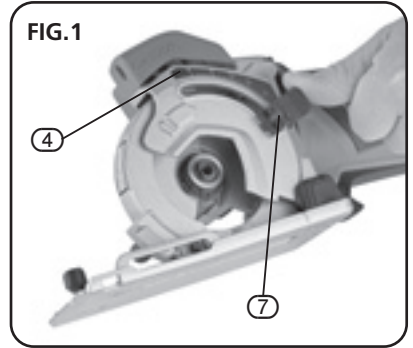

8.2 CHANGING THE SAW BLADE- FIGS. 2-3

WARNING: Incorrect positioning of the saw blade can permanently damage the plunge saw.

- Ensure the saw is unplugged from the mains supply.
- Press and hold the spindle lock button (16) and release the saw blade locking flange bolt (8) by using the supplied hex. key (21) (turn clockwise to release). Remove the saw blade locking flange bolt (8) (Figs 2 & 3).
- Set the cutting depth to the maximum. (See "8.1-Setting the cutting depth").
- Plunge the base plate (18) to expose the saw blade.
- Remove the saw blade.
- The installation of the blade is carried out in the reverse order.
- Press the spindle lock button (16) (until it engages) and tighten the saw blade locking flange bolt (8) securely.

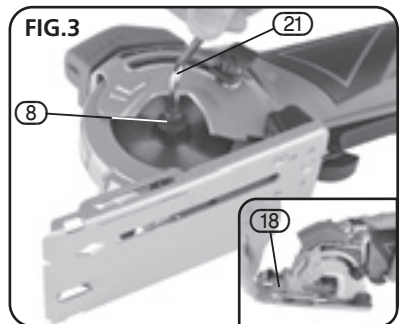
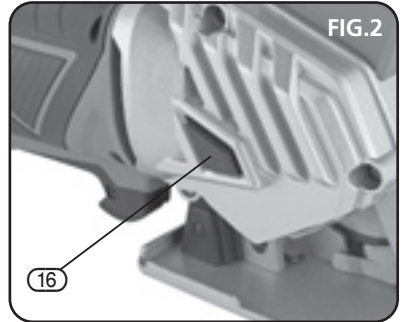

NOTE: The directional arrow on the saw blade must be the same with the arrow showing the direction of rotation (running direction shown on the tool).

9. OPERATING THE MINI PLUNGE SAW

NOTE: Remove the plug from the socket before carrying out adjustment, servicing or maintenance.

9.1 SWITCHING ON THE PLUNGE SAW - FIG. 4

WARNING: Before switching the machine on, check that the saw blade is properly fitted, operates efficiently and that the saw blade locking flange bolt (8) is securely tightened.

Push the lock-off button (6) forward (Fig 4), depress On/Off switch trigger (5) inwards and keep it pressed at the same time.

When you release the trigger, the main switch returns automatically to it's initial position and will turn the machine off.

WARNING: The saw blade will continue to rotate for a few moments even after the saw has been switched off.

WARNING: Always cut in a forward direction NEVER draw the tool backwards.

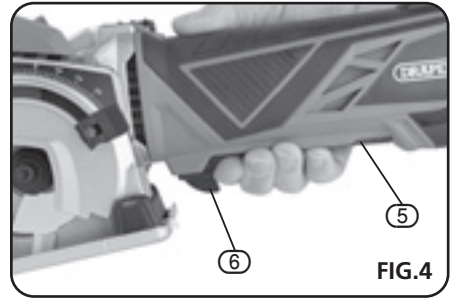

9.2 RELEASING THE PLUNGE STOP - FIG.5

Press the back of the safety lock button (3) down and hold.

NOTE: Pressing down the safety lock button (3) unlocks the plunge cutting mechanism so that the motor can be moved downwards. The saw blade will then emerge from below the base plate (18).

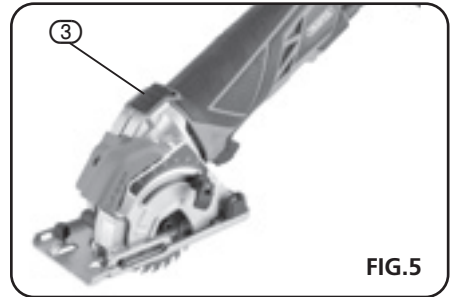

9.3 SETTING THE PARALLEL GUIDE FENCE - FIG.6

Release the parallel guide locking screw (11) on the base plate (18) and set the guide fence into the guide fence slot (10). Set to the required width and retighten the parallel guide locking screw (11).

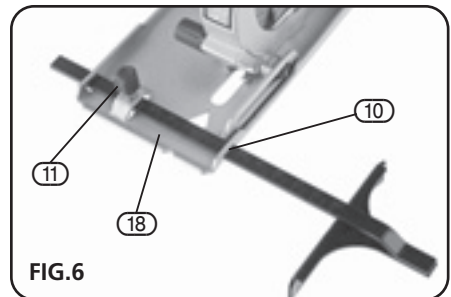

9. BASIC CIRCULAR SAW OPERATIONS

9.4 LASER LINE GENERATOR - FIG. 7

WARNING: Laser radiation. Do not stare into beam. Class 2 laser product.

The laser on/off switch (2) is located in front of the safety lock button (3) for the mechanical plunge stop. To turn on the laser, switch the on/off switch (2) to the "I" position, the laser beam aperture (1) will now operate.

To turn off the laser, press the on/off switch (2) to the "O" position.

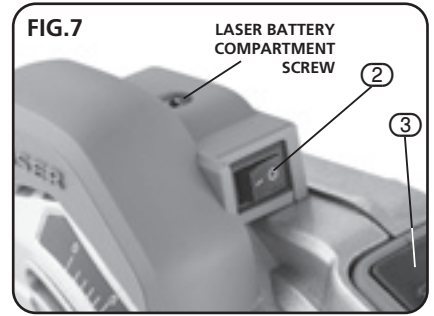

To use the laser before making the cut;

- 1) Make sure the line of the cut is on the workpiece.
- 2) Adjust the depth of cut as required.
- 3) Plug the machine into the mains supply and switch it on.
- 4) Switch on the laser beam aperture (1) using the laser on/off switch (2).
- 5) When the saw blade is at the maximum speed (approx. 5 seconds), place the saw on the workpiece.
- 6) Align the beam with the mark on the workpiece and slowly plunge the saw blade into the work piece. Push the saw forward using both hands, keeping the red light beam on the mark. When the cut is finished, raise the saw and switch off.
- 7) Switch off the laser.

NOTE: Laser is powered by 2 x 1.5V LR44 button cells. Access to these, should they need to be replaced is achieved by removing the plastic laser housing after removing the screw that holds it in place.

9.5 LINE FOLLOWING- FIG. 8

A V-shaped pointer is located at the front and a pointer at the rear position of the base plate (18) to indicate where a line can be followed when cutting using the saw blade.

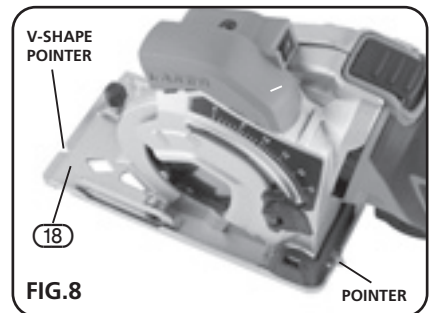

9. BASIC CIRCULAR SAW OPERATIONS

9.6 DUST EXTRACTION - FIG. 9

WARNING: As the plunge saw has a fully enclosed blade, forced dust extraction can be particularly prominent. Dust extraction should be used for all but small trimming jobs.

To connect the hose to the dust extraction outlet;

- 1) Push the connection hose (22) onto the dust extraction outlet (17).
- 2) Connect a vacuum device approved for the extraction of the material being cut to the connection hose.

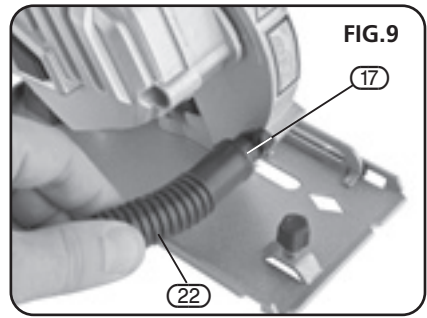

Ensure that the vacuum to be used is recommended for use with the plunge saw. Powered dust extraction is recommended when a lot of cutting is required as fewer stoppages are needed for cleaning the plunge saw and surrounding work area.

Powered dust extraction should always be used in the process of cutting hazardous materials i.e, hardwoods, MDF or ceramics.

NOTE: Wearing of a FFP2 mask is recommended.

NOTE: Only use a vacuum cleaner or dust extractor specifically designed for the job being done. Many extractors will accommodate wood dust extraction but not all will accommodate metal swarf and fillings.

9. BASIC CIRCULAR SAW OPERATIONS

9.7 CUTTING - FIG. 10

WARNING: Before using the machine, check the removable protection cover (12) is secured and can function correctly.

Always cut in a forward direction. Never draw the saw backwards. If you are unfamiliar with the functionality of the saw then test it first by cutting some thin wood until proficient.

- a) Check the specifications to ensure that the material to be cut is suitable.
- b) Fit the correct saw blade ensuring it is sharp, undamaged and fit for purpose.
- c) Set the depth of the cut (see page 13).
- d) Place the material to be cut onto a flat surface such as a workbench, table or floor. The material needs to be held firm in a fixed position.

WARNING: Be careful not to damage blade or supporting surface beneath material being cut.

- e) Plug the plunge saw into a mains supply and switch laser (1) on (if required).
- f) Grip the tool firmly (see "switching on the plunge saw" page 14) and rest its base plate onto the surface of the material to be cut when plunge cutting. Do not plunge the saw blade into the material.
- g) Turn on the tool and allow the blade to run up to speed. Then depress the safety lock button (3) and plunge the blade into the material gently. Push the tool forwards along the line to be cut.
- h) Slight force should be used when guiding the tool along the cut line. Any excessive force will cause fatigue to the operator and wear to the blade and tool. Excessive force is also likely to cause the machine temperature cut-out to trip, resulting in the saw not being operational (until it cools down).
- i) Make sure that the base plate (18) is always held flat on top of the material that is being cut. This is particularly important at the start or finish of a cut or if thin strips are being cut where the base plate is not fully supported.
- j) Once the cut is finished, lift the tool from the work surface before switching off. If excessive dust is present after operation, keep the tool switched on for a few additional seconds to allow the dust to clear from within the tool via the dust extraction outlet (17).

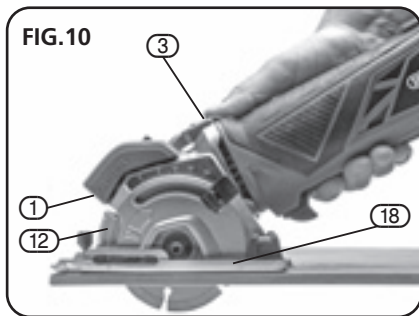

9. BASIC CIRCULAR SAW OPERATIONS

9.8 CUT-OUTS- FIG. 11

NOTE: Plunge cutting may not be possible in some harder materials.

Always cut in a forward direction. Never draw the saw backwards. If you are unfamiliar with the functionality of the saw then test it first by cutting some thin wood until proficient.

- a) Firstly, choose the correct saw blade for appropriate material and set the depth of the cut. Plug into the mains supply and place the metal base plate (18) flat and level onto the work surface prior to cutting. Make sure that the front indication pointer on the base plate aligns with the start line of the cut (see page 15).
- b) Turn on the tool and allow the blade to run up to speed. When ready, plunge the saw blade into the material firmly but slowly. Push the saw forwards along the cut line (never draw the saw backwards during cutting).
- c) Once you have completed the cut along the cut line, lift the tool from the surface before turning it off. If there is a large amount of excess dust created, keep the saw switched on for a few extra seconds to allow the dust to clear from the saw.
- d) Cutting out tips;
 - If the cut is to be covered, i.e. by a vent cover, the corners can be overlapped to ensure that the waste material is completely detached.
 - If the cut is to be seen, do not overlap the corners. As the cutting blade is circular, the waste material will not be fully detached. The corners will require finishing with a knife or square file. If the material is thin and the back surface unimportant, the waste material can just be pushed out.
 - Where there is access to the back surface of the material that is being cut, the cut out can be marked out with an over cutting allowance. The cut can then be made from the back surface thus ensuring perfect corners on the front surface.

NOTE: The blade depth of plunge, the thickness of the material being cut and the blade diameter need to be considered if accurate cutting is required. Never pull the saw backwards. Complete several practise cuts before attempting final cut.

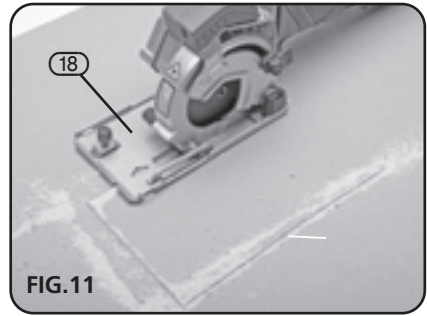

FIG. 11

9. BASIC CIRCULAR SAW OPERATIONS

9.9 CUTTING TOUGH OR ABRASIVE MATERIALS - FIG. 12

WARNING: Never cut materials that produce toxic fumes or dust such as PTFE and asbestos.

NOTE: When cutting tougher materials such as metals, more force will be required to hold the workpiece and additional clamping may be required.

a) Sheet metal (HSS Blade).

Always set the depth adjustment to at least 1mm deeper than the actual material thickness to avoid the saw blade riding up over the surface.

Remove burr and rust as this will hinder the feed across the material to be cut.

Polish applied to the base plate of the tool, or to the surface of material being cut, allows more efficient cutting.

The saw is only suitable for cutting brass, copper, lead, aluminium or galvanised mild steel. (3mm max.).



b) Ceramic tiles, slates etc (Diamond Blade).

Only use a correct blade suitable for cutting this type of material.

Always use with a suitable vacuum cleaner or dust extractor connected to the tool as the dust can be hazardous to the user and prevent the guard operating correctly (8mm max.).

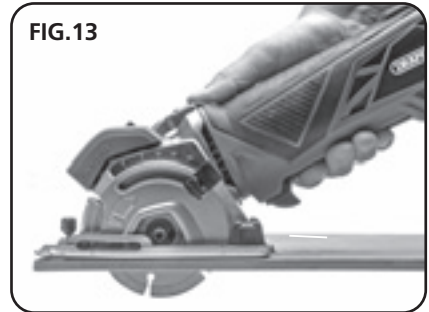

c) Wood (T.C.T. Blade).

Only use a correct blade suitable for cutting this type of material.

Always use with suitable vacuum cleaner or dust extractor connected to the tool as the dust can be hazardous to the user and prevent the guard from operating correctly. (28.5mm max.).

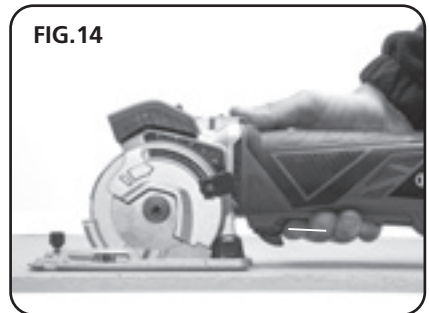

10. MAINTENANCE

10.1 MAINTENANCE

Regular inspection and cleaning reduces the necessity for maintenance operations and will keep your tool in good working condition.

The motor must be correctly ventilated during tool operation. For this reason avoid blocking the air inlets. After use disconnect the tool from the power supply and vacuum the ventilation slots.

If the replacement of the supply cord is necessary, this has to be done by the manufacturer or his agent in order to avoid a safety hazard.

NOTE: Remove the plug from the socket before carrying out adjustment, servicing or maintenance.

Blades

- Always use a sharp blade.
- If the saw does not cut as well as expected or overheats the most common cause is a blunt blade.
- It is difficult to tell whether a saw blade is blunt. If it isn't working efficiently then replace with a new blade.
- Blades are consumable items.
- Be cautious when changing a blade as it can become hot especially after usage. Before replacing the blade, allow it to cool.

11. TROUBLESHOOTING

- **NOTE:**

Remove the plug from the socket before carrying out adjustment, servicing or maintenance.

PROBLEM	CAUSE	REMEDY
Machine does not start.	<ol style="list-style-type: none">1. Fuse.2. Brushes worn.3. Other.	<ol style="list-style-type: none">1. Replace time delay fuse or reset circuit breaker.2. Have brushes replaced by an authorised service centre.3. Contact an authorised service centre.
Poor cutting performance.	<ol style="list-style-type: none">1. Saw blade blunt.2. Saw blade incorrectly mounted.3. Incorrect saw blade selection.	<ol style="list-style-type: none">1. Replace saw blade.2. Remove & refit saw blade as per instructions.3. Seek advice on suitable saw blades.
Saw vibrates.	<ol style="list-style-type: none">1. Saw blade distorted.2. Saw blade incorrectly mounted.	<ol style="list-style-type: none">1. Stop machine immediately & replace blade.2. Stop machine immediately. Remove & refit saw blade as per instructions.
Laser doesn't work	<ol style="list-style-type: none">1. Batteries.2. Other.	<ol style="list-style-type: none">1. Replace batteries (2 x LR44).2. Check for damage, contact authorised service centre.

12. EXPLANATION OF SYMBOLS

12.1 EXPLANATION OF SYMBOLS



Warning!
Wear dust mask.



Warning!
Read the instruction manual



Warning!
Wear suitable eye/face
protection.



Warning!
Wear ear defenders.



WEEE
Do not dispose of Waste Electrical
& Electronic Equipment in with
domestic rubbish



Class II construction
(Double insulated).

13. DISPOSAL

13.1 DISPOSAL

- At the end of the machine's working life, or when it can no longer be repaired, ensure that it is disposed of according to national regulations.
- Contact your local authority for details of collection schemes in your area.

In all circumstances:

- Do not dispose of power tools with domestic waste.
- Do not incinerate.
- Do not abandon in the environment.
- Do not dispose of WEEE* as unsorted municipal waste.



* Waste Electrical & Electronic Equipment.

- **DRAPER TOOLS LIMITED,**
Hursley Road, Chandler's Ford,
Eastleigh, Hampshire. SO53 1YF. U.K.
- **Help Line:** (023) 8049 4344
- **Sales Desk:** (023) 8049 4333
- **General Enquiries:** (023) 8026 6355
- **Service/Warranty Repair Agent**
For aftersales servicing or warranty repairs, please
contact the Draper Tools Help Line for details of an
agent in your local area.

YOUR DRAPER STOCKIST

RDMC0916

