

Double Panel Designer Radiator - Colour: White - Size: 1800*236*78

Product Specification:

Code:	RAD03
Barcode:	5215000301001
Product Weight (KG):	21.4
Standards:	BS EN 442-1:1996
Construction Material:	Low Carbon Steel
Installation Type:	Wall Mounted
Colour / Finish:	White
Certification (WRAS, TMV etc):	No
BTU:	2695
Watts:	790
Hang Type:	Vertical
Rails:	n/a
Columns:	4
Pipe Centres (mm):	60 or 306
Wall to Face (mm):	105
Central heating installation:	Yes
Electrical element installation:	No
Bar Type:	Double
Panel Type:	Round



Dimensions:

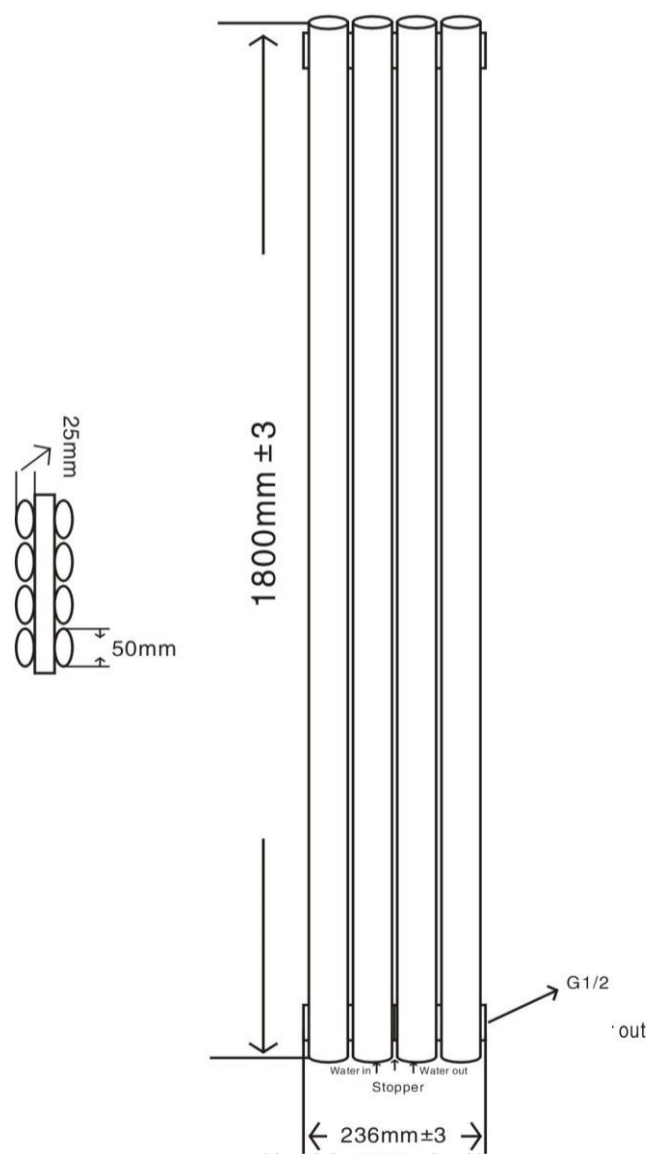

Packaging Dimensions:

Single SKU Box	Length (mm)	Width (mm)	Hight (mm)	G.W (Kg)
	1860	315	115	24.1

The information contained on this page was correct at date of issue. Fitting dimensions are provided as a guide only. Some variation may occur due to manufacturing tolerances. Cassellie Ltd peruses a policy of continuing improvement in design and performance of its products and so reserves the right to change specifications without prior notice