

BAUKER 

PDI750G

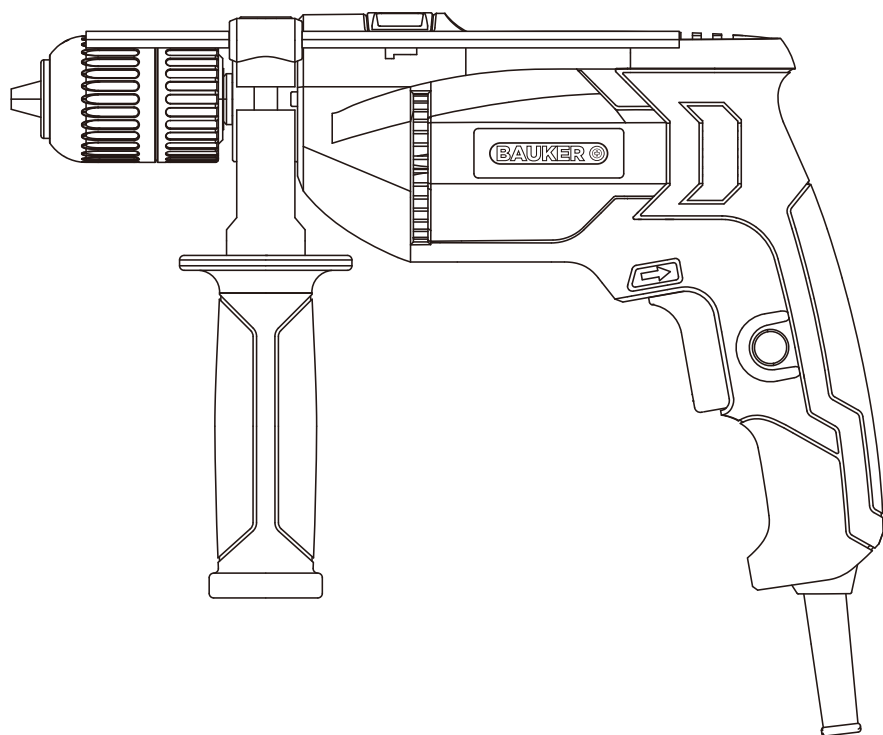

**750W 13MM IMPACT DRILL
ORIGINAL INSTRUCTION MANUAL**

GENERAL POWER TOOL SAFETY WARNINGS

 **WARNING! Read all safety warnings and all instructions.** Failure to follow the warnings and instructions may result in electric shock, fire and/or serious injury.

Save all warnings and instructions for future reference.

The term "power tool" in the warnings refers to your mains-operated (corded) power tool or battery-operated (cordless) power tool.

1) Work area safety

- a) Keep work area clean and well lit.** Cluttered or dark areas invite accidents.
- b) Do not operate power tools in explosive atmospheres, such as in the presence of flammable liquids, gases or dust.** Power tools create sparks which may ignite the dust or fumes.
- c) Keep children and bystanders away while operating a power tool.** Distractions can cause you to lose control.

2) Electrical safety

- a) Power tool plugs must match the outlet. Never modify the plug in any way. Do not use any adapter plugs with earthed (grounded) power tools.** Unmodified plugs and matching outlets will reduce risk of electric shock.
- b) Avoid body contact with earthed or grounded surfaces, such as pipes, radiators, ranges and refrigerators.** There is an increased risk of electric shock if your body is earthed or grounded.
- c) Do not expose power tools to rain or wet conditions.** Water entering a power tool will increase the risk of electric shock.
- d) Do not abuse the cord. Never use the cord for carrying, pulling or unplugging the power tool. Keep cord away from heat, oil, sharp edges or moving parts.** Damaged or entangled cords increase the risk of electric shock.
- e) When operating a power tool outdoors, use an extension cord suitable for outdoor use.** Use of a cord suitable for outdoor use reduces the risk of electric shock.
- f) If operating a power tool in a damp location is unavoidable, use a residual current device (RCD)**

protected supply. Use of an RCD reduces the risk of electric shock.

3) Personal safety

- a) **Stay alert, watch what you are doing and use common sense when operating a power tool. Do not use a power tool while you are tired or under the influence of drugs, alcohol or medication.** A moment of inattention while operating power tools may result in serious personal injury.
- b) **Use personal protective equipment. Always wear eye protection.** Protective equipment such as dust mask, non-skid safety shoes, hard hat, or hearing protection used for appropriate conditions will reduce personal injuries.
- c) **Prevent unintentional starting. Ensure the switch is in the off-position before connecting to power source and/or battery pack, picking up or carrying the tool.** Carrying power tools with your finger on the switch or energising power tools that have the switch on invites accidents.
- d) **Remove any adjusting key or wrench before turning the power tool on.** A wrench or a key left attached to a rotating part of the power tool may result in personal injury.
- e) **Do not overreach. Keep proper footing and balance at all times.** This enables better control of the power tool in unexpected situations.
- f) **Dress properly. Do not wear loose clothing or jewellery. Keep your hair, clothing and gloves away from moving parts.** Loose clothes, jewellery or long hair can be caught in moving parts.
- g) **If devices are provided for the connection of dust extraction and collection facilities, ensure these are connected and properly used.** Use of dust collection can reduce dust-related hazards.

4) Power tool use and care

- a) **Do not force the power tool. Use the correct power tool for your application.** The correct power tool will do the job better and safer at the rate for which it was designed.
- b) **Do not use the power tool if the switch does not turn it on and off.** Any power tool that cannot be controlled with the switch is dangerous and must be repaired.

- c) **Disconnect the plug from the power source and/or the battery pack from the power tool before making any adjustments, changing accessories, or storing power tools.** Such preventive safety measures reduce the risk of starting the power tool accidentally.
 - d) **Store idle power tools out of the reach of children and do not allow persons unfamiliar with the power tool or these instructions to operate the power tool.** Power tools are dangerous in the hands of untrained users.
 - e) **Maintain power tools. Check for misalignment or binding of moving parts, breakage of parts and any other condition that may affect the power tool's operation. If damaged, have the power tool repaired before use.** Many accidents are caused by poorly maintained power tools.
 - f) **Keep cutting tools sharp and clean.** Properly maintained cutting tools with sharp cutting edges are less likely to bind and are easier to control.
 - g) **Use the power tool, accessories and tool bits etc. in accordance with these instructions, taking into account the working conditions and the work to be performed.** Use of the power tool for operations different from those intended could result in a hazardous situation.
- 5) **Service**
- a) **Have your power tool serviced by a qualified repair person using only identical replacement parts.** This will ensure that the safety of the power tool is maintained.

HAMMER SAFETY WARNINGS

- 1. **Wear ear protectors.** Exposure to noise can cause hearing loss.
- 2. **Use auxiliary handle(s), if supplied with the tool.** Loss of control can cause personal injury.
- 3. **Hold power tool by insulated gripping surfaces, when performing an operation where the cutting accessory may contact hidden wiring or its own cord.** Cutting accessory contacting a "live" wire may make exposed metal parts of the power tool "live" and could give the operator an electric shock.

SYMBOL



To reduce the risk of injury, user must read instruction manual



Wear eye protection



Wear ear protection



Wear dust mask



Double insulation



Waste electrical products must not be disposed of with household waste. Please recycle where facilities exist. Check with your local authorities or retailer for recycling advice.

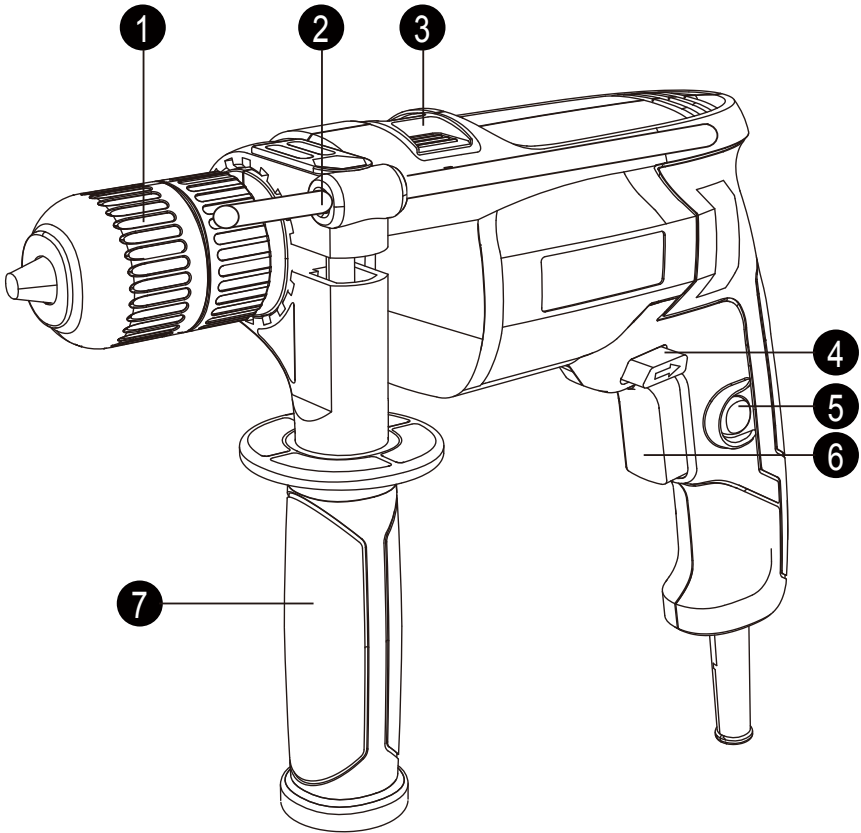

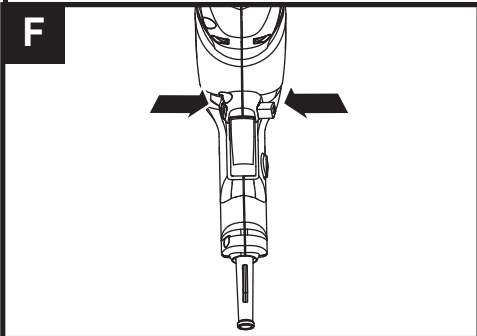
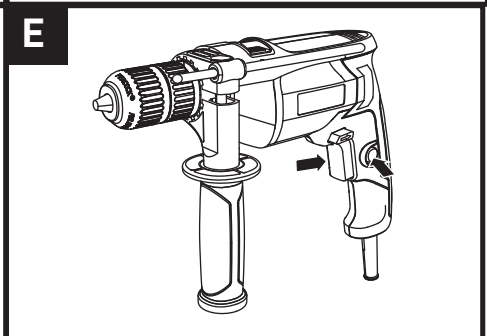
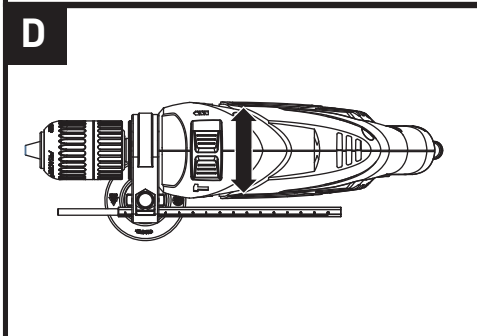
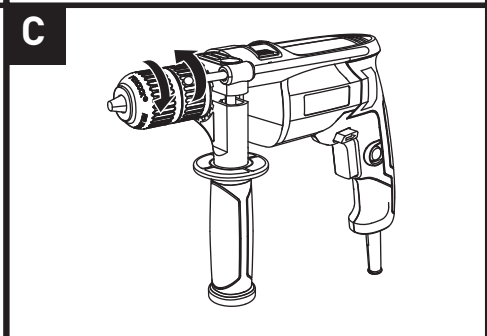
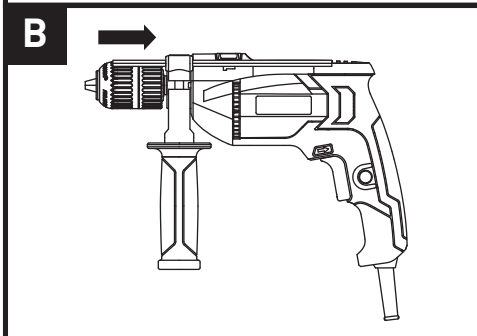
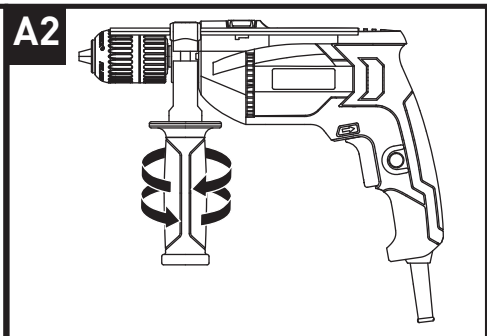
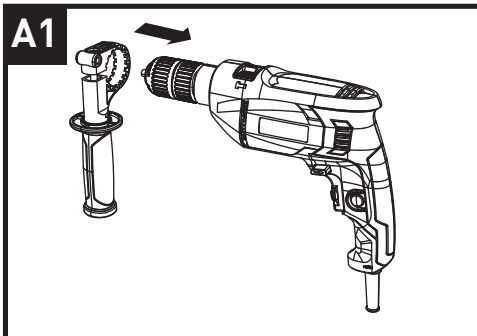

COMPONENT LIST

1. KEYLESS CHUCK
 2. DEPTH GAUGE
 3. DRILL/IMPACT ACTION SELECTOR SWITCH
 4. FORWARD/REVERSE SELECTOR SWITCH
 5. SWITCH LOCK-ON BUTTON
 6. ON/OFF SWITCH
 7. AUXILIARY HANDLE
-

Not all the accessories illustrated or described are included in standard delivery.

TECHNICAL DATA

Type PDI750G / PDI750G.1 (PDI-designation of machinery, representative of Impact Drill)

Rated voltage	230 -240V~ 50 Hz
Rated power	750 W
Rated no load speed	0-3000 /min
Impact rate	0- 48000 /min
Chuck capacity max	13 mm
Drilling capacity :	
Steel	13 mm
Masonry	16mm
Wood	30 mm
Protection class	 /II
Weight	1.81 kg

ACCESSORIES

Auxiliary handle	1
Depth gauge	1

We recommend that you purchase your accessories from the same store that sold you the tool. Use good quality accessories marked with a well-known brand name. Choose the type according to the work you intend to undertake. Refer to the accessory packaging for further details. Store personnel can assist you and offer advice.

NOISE INFORMATION

A weighted sound pressure

$$L_{pA} = 92\text{dB(A)}$$

$$K_{pA} = 3\text{dB(A)}$$

A weighted sound power

$$L_{WA} = 103\text{dB(A)}$$

$$K_{WA} = 3\text{dB(A)}$$

Wear ear protection.



VIBRATION INFORMATION

Vibration total values (triax vector sum) determined according to EN 60745;

Impact drilling into concrete:	Vibration emission value $a_{h,1D} =$ 6.66 m/s ²	Uncertainty K = 1.5 m/s ²
Drilling into metal:	Vibration emission value $a_{h,D} =$ 2.62 m/s ²	Uncertainty K = 1.5 m/s ²

The declared vibration total value may be used for comparing one tool with another, and may also be used in a preliminary assessment of exposure.

 **WARNING!** The vibration emission value during actual use of the power tool can differ from the declared value depending on the ways in which the tool is used dependant on the following examples and other variations on how the tool is used:

How the tool is used and the materials being cut or drilled.

The tool being in good condition and well maintained

The use the correct accessory for the tool and ensuring it is sharp and in good condition.

The tightness of the grip on the handles and if any anti vibration accessories are used.

And the tool is being used as intended by its design and these instructions.

This tool may cause hand-arm vibration syndrome if its use is not adequately managed

 **WARNING!** To be accurate, an estimation of exposure level in the actual conditions of use should also take account of all parts of the operating cycle such as the times when the tool is switched off and when it is running idle but not actually doing the job. This may significantly reduce the exposure level over the total working period.

Helping to minimize your vibration exposure risk.

ALWAYS use sharp chisels, drills and blades.

Maintain this tool in accordance with these instructions and keep well lubricated (where appropriate).

If the tool is to be used regularly then invest in anti vibration accessories.

Plan your work schedule to spread any high vibration tool use across a number of days.

OPERATING INSTRUCTIONS



NOTE: Before using the tool, read the instruction book carefully.

Intended Use

The machine is intended for impact drilling in brick, concrete and stone as well as for drilling in wood, metal and plastic.

1. AUXILIARY HANDLE (SEE FIG. A1, A2)

Slide the handle onto the drill and rotate to the desired working position. Make sure that the teeth on the grip fit in the protrusions on the handle collar. To clamp the auxiliary handle, rotate the handgrip clockwise. To loosen the auxiliary handle, rotate the hand grip anti-clockwise. Always use the auxiliary handle.



WARNING: Always check and rotate the handle tightly before using to avoid any accident.

2. INSTALLING THE DEPTH GAUGE (SEE FIG. B)

The depth gauge can be used to set a constant depth to drill. To use the depth gauge, loosen the handle by rotating the bottom section of handle anti-clockwise. Insert the depth gauge through hole in handle. Slide the depth gauge to required depth and tighten fully.

3. INSERTING A TOOL INTO THE CHUCK (SEE FIG. C)



WARNING: Remove the plug from the socket before carrying out any adjustment, servicing or maintenance.

To open the chuck jaws rotate the front section of the chuck while holding the rear section. Insert the drill bit between the chuck jaws and rotate the front section in the opposite direction while holding the rear section. Ensure that the drill bit is in the center of the chuck jaws. Finally, firmly rotate the two separate chuck sections in opposite directions. Your drill bit is now locked in the chuck.

4. HAMMER OR DRILLING CHANGE (SEE FIG. D)

When drilling masonry and concrete, choose the hammer position “”.

When drilling in wood, metal and plastic, choose the drill position. “”.

5. ON/OFF SWITCH

Depress the switch to start the tool and release it to stop your tool.

6. SWITCH LOCK-ON BUTTON (SEE FIG. E)

Depress on/off switch then lock-on button, release on/off switch first and lock-on button second. Your switch is now locked on for continuous use. To switch off your tool just depress and release the on/off switch.

7. VARIABLE SPEED CONTROL

The on/off switch is also a variable speed switch that delivers higher speed and torque with increased trigger pressure. Speed is controlled by the amount of switch trigger depression.

8. FORWARD AND REVERSE ROTATION CONTROL (SEE FIG. F)

To change the rotational direction, push the forward/reverse selector switch to the right position (as viewed from the front of the drill). The rotation will now be forward rotation. Push the forward/reverse selector switch to the left position. The rotation will be backward rotation.



Warning: Never change the direction of rotation when the tool is rotating, wait until it has stopped.

WORKING HINTS FOR YOUR IMPACT DRILL

1. Drilling masonry and concrete

Select the drill/impact action selector switch to the “hammer symbol” position. Tungsten carbide drill bits should always be used for drilling masonry, concrete etc with a high speed.

2. Drilling steel

Select the drill/impact action selector switch to the “drill symbol” position. HSS drill bits should always be used for drilling steel with a lower speed.

3. Pilot holes

When drilling a large hole in tough material (i.e. steel), we recommend drilling a small pilot hole first before using a large drill bit.

4. Drilling tiles

Select the drill/impact action selector switch to the “drill symbol” position to drill the tile. When tile has been penetrated, switch over to “hammer symbol” position.

5. Cool the motor

If your power tool becomes too hot, set the speed to maximum and run no load for 2-3 minutes to cool the motor.

MAINTENANCE

Remove the plug from the socket before carrying out any adjustment, servicing or maintenance.

Your power tool requires no additional lubrication or maintenance. There are no user serviceable parts in your power tool.

Never use water or chemical cleaners to clean your power tool. Wipe clean with a dry cloth.

Always store your power tool in a dry place. Keep the motor ventilation slots clean.

Keep all working controls free of dust.

Occasionally you may see sparks through the ventilation slots. This is normal and will not damage your power tool.

If the supply cord is damaged, it must be replaced by the manufacturer, its service agent or similarly qualified persons in order to avoid a hazard.

TROUBLESHOOTING

1. If your power tool does not start, check the plug on the power supply first.
2. If the drill doesn't work properly, check the drill bit for sharpness, replace drill bit if worn. Check that the drill is set to forward rotation for normal use.
3. If a fault can not be rectified, return the tool to an authorized dealer for repair.

ENVIRONMENTAL PROTECTION



Waste electrical products should not be disposed of with household waste. Please recycle where facilities exist. Check with your local authorities or retailer for recycling advice.

PLUG REPLACEMENT (ONLY FOR REWIRABLE PLUG OF UK & IRELAND)

If you need to replace the fitted plug then follow the instructions below.

IMPORTANT

The wires in the mains lead are colored in accordance with the following code:

BLUE – NEUTRAL

BROWN – LIVE

As the colors of the wires in the mains lead of this appliance may not correspond with the coloured markings identifying the terminals in your plug, proceed as follows. The wire which is coloured blue must be connected to the terminal which is marked with N. The wire which is coloured brown must be connected to the terminal which is marked with L.



WARNING:

Never connect live or neutral wires to the earth terminal of the plug. Only fit an approved BS1363/A plug and the correct rated fuse.

NOTE: If a moulded plug is fitted and has to be removed take great care in disposing of the plug and severed cable, it must be destroyed to prevent engaging into a socket.

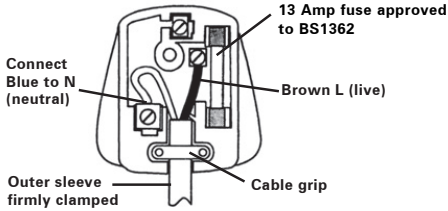

DECLARATION OF CONFORMITY

We,
Positec Power Tools (Europe) Ltd,
PO Box 6242, Newbury, RG14 9LT, UK

Declare that the product
Description **Impact Drill**
Type designation **PDI750G (PDI-designation of machinery, representative of Impact Drill)**
Function **Boring holes in various materials**

Complies with the following Directives:
2006/42/EC, 2011/65/EU, 2014/30/EU

Standards conform to
EN 60745-1, EN 60745-2-1, EN 55014-1, EN 55014-2, EN 61000-3-2, EN 61000-3-3

The person authorized to compile the technical file,
Name **Jim Kirkwood**
Address **Positec Power Tools (Europe) Ltd,
PO Box 6242, Newbury, RG14 9LT, UK**



2018/01/26
Allen Ding
Deputy Chief Engineer, Testing & Certification
Positec Technology (China) Co., Ltd
18, Dongwang Road, Suzhou Industrial
Park, Jiangsu 215123, P. R. China

