

FLO-RES-KIT

Flow restrictor kit for AccuBoost



salamanderpumps.co.uk

Description

The flow restrictor kit (FLO-RES-KIT) – allows the flowrate from a tank to be adjusted. To increase the flow for a shorter period of time, a higher value flow restrictor should be used. To reduce the flow for a longer period of time, a lower value flow restrictor should be used. A selection of flow restrictors is provided to allow the best balance of flow and time to be achieved.

Kit Contents

- 2x Non-Return Valves (NRV)
- 1x 2 L/min flow restrictor (Green)
- 1x 4 L/min flow restrictor (Pink)
- 1x 6 L/min flow restrictor (Grey)
- 1x 8 L/min flow restrictor (White)
- 1x 10 L/min flow restrictor (Yellow)
- 1x 12 L/min flow restrictor (Brown)
- 1x 18 L/min flow restrictor (Pink)

Step 4

Place the brass inlet/outlet connector onto a flat surface - with the large female threads down.

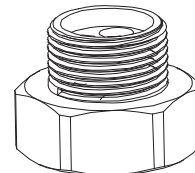

Step 5

Using a blunt object, such as a flat headed screwdriver, push out the existing flow restrictor (Refer to image in Step 6). Note, 450 models will not contain a flow restrictor or non-return valves.

Step 8

Ensure that the brass inlet/outlet connector contains 2x non-return valves, in the correct orientation shown. To insert these, push into the correct holes by hand and then fully push them home with a blunt tool until you hear a click.

Step 9

Ensure the brass inlet/outlet connector contains the washer and reconnect it to the tank

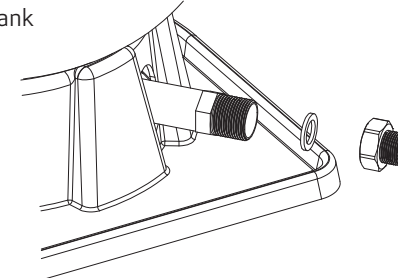

Step 1

Disconnect electrical supply to the pump (on pumped versions). Turn off water supply to the AccuBoost unit and completely empty the tank of water by opening outlets, such as a tap.

Step 2

Remove the tank connector hose.

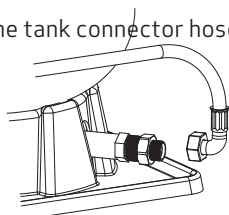

Step 3

Remove the brass inlet/outlet connection from the tank.

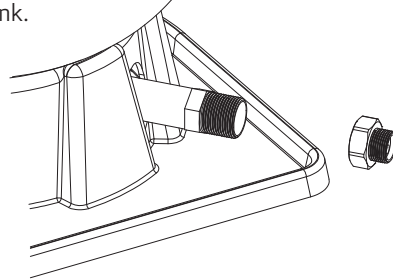

Step 6

Turn the brass inlet/outlet connector over so that the small male threads are supported on the flat surface.

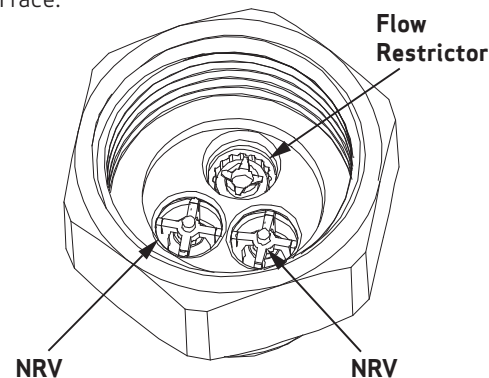

Step 7

Select the desired flow restrictor and place into the flow restrictor hole, observing the correct orientation. Push it fully home with a blunt object.

Step 10

Reconnect the tank hose

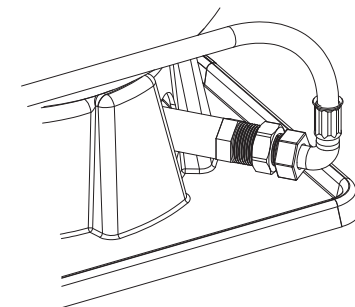

Step 11

Continue to follow the installation guide supplied with the AccuBoost unit. A copy of the AccuBoost installation guide can be downloaded from our website:

www.salamanderpumps.co.uk