

The Astro Range of Boilers

the ultimate solution for central heating & hot water

INSTALLATION & TECHNICAL MANUAL



If you require any further assistance:

Telephone: 01698 820533

Fax: 01698 825697

E-mail: info@electric-heatingcompany.co.uk
or visit our website www.electric-heatingcompany.co.uk

CONTENT

1. SAFETY	Page 1
1.1 SYMBOL KEY	Page 1
1.2 SAFETY PRECAUTIONS	Page 1
1.3 GENERAL EXPLANATIONS	Page 2
1.4 INSTRUCTIONS AND BUILDING REGULATIONS	Page 2
1.5 C.O.S.H.H	Page 3
1.6 PREPARATION	Page 3
1.6.1 Load Check	Page 3
1.6.2 Boiler Location	Page 3
1.6.3 Central Heating Installation	Page 3
2. INTRODUCTION	Page 3
2.1 APPERANCE AND EXTERNAL DIMENSIONS	Page 3
2.2 COMPONENTS OF THE BOILER	Page 4
2.3 MAIN FEATURES OF THE BOILER	Page 5
3. MOUNTING AND INSTALLATION	Page 6
3.1 OPENING THE BOX	Page 6
3.2 MOUNTING INSTRUCTIONS	Page 6
3.3 MINIMUM SPACES FOR INSTALLATION	Page 7
3.4 WALL MOUNTING	Page 7
3.5 HEATING AND DHW SYSTEM INSTALLATION CONNECTIONS	Page 8/9
3.5.1 BOILER INSTALLATION SCHEMATICS	Page 10
3.5.2 CIRCULATION PUMP IMFORMATION	Page 11
3.6 ELECTRICAL CONNECTIONS	Page 12
3.6.1 Electricity Connection Precautions	Page 13
3.6.2 Removing the Front Boiler Cover	Page 14
3.6.3 Electricity Supply Connection	Page 14
3.6.4 Electrical Connection Diagram 230V (Single Phase)	Page 15
3.6.5 Electrical Connection Diagram 400V (3-phase)	Page 16
3.7 MAIN PCB DIP SWITCHES	Page 17
3.7.1 Switches 1	Page 18
3.7.2 Switches 2	Page 18
3.8 ROOM THERMOSTAT CONNECTION	Page 19
3.9 ELECTRICITY CONNECTION PARAMETERS	Page 19

4. COMMISSIONING	Page 20
4.1 FILLING WATER TO THE SYSTEM	Page 20
4.2 STARTING UP	Page 21
5. USER INSTRUCTIONS	Page 22
5.1 CONTROL PANEL	Page 22
5.2 ERROR CODES	Page 23
5.3 TROUBLE SHOOTING	Page 24
6. PRODUCT SAFETY	Page 25
6.1 BUILT-IN RCD DEVICE (SHORT CIRCUIT RELAY)	Page 25
6.2 HEATING TANK FLOAT LEVEL SENSOR (H6)	Page 25
6.3 LOW WATER PRESSURE	Page 25
6.4 OVERHEAT LIMIT THERMOSTAT	Page 25
6.5 SHORT CIRCUIT THERMOSTAT	Page 25
6.6 FROST PROTECTION	Page 26
6.7 DOMESTIC HOT WATER NTC SENSOR	Page 26
6.8 CENTRAL HEATING NTC SENSOR	Page 26
6.9 HIGH WATER PRESSURE PROTECTION	Page 26
6.10 ANTI PUMP LOCKING	Page 26
6.11 3-WAY VALVE ACTUATOR MOTOR SAFETY	Page 26
6.12 AUTOMATIC BY-PASS	Page 26
7. TECHNICAL TABLE	Page 27
8. MAINTENANCE	Page 28
9. GUARANTEE CONDITIONS	Page 28
10. EXPLODED VIEW	Page 29
10.1 MAIN HEAT EXCHANGER GROUP DETAIL	Page 30
10.2 HYDROLIC GROUP DETAIL	Page 31
10.3 RELAY BOARD GROUP DETAIL	Page 32
10.4 EXPLODED VIEW PARTS LIST	Page 33



This appliance is not intended for use by persons (including children) with reduced physical, sensory or mental capabilities or lack of experience and knowledge unless they have been given supervision or instruction concerning the use of the appliance by a person responsible for their safety.

Children should be supervised to ensure that they do not play with the appliance.



1. SAFETY



1.1 SYMBOL KEY

This symbol expresses the risk of serious personal injury or death.

This symbol expresses the risks which can cause minor injury or harm to the environment and goods.



1.2 SAFETY PRECAUTIONS



Isolate the Main Power Supply to the boiler before removing the cover.

Failing to isolate the device could result in electric shock.

Personal injury from Hot surfaces or Sharp edges within the boiler.



Protection of Main Power Cables.

A result of electric shock or a fire risk could be possible if power cables are damaged or incorrectly installed



Do not store objects on top of the device.



Injury resulting from falling objects from the device due to vibration.



Damage to surrounding objects, people or pets resulting from falling objects.

Internal damage to the device if objects fall into the unit.



Do not Stand on the device.

Personal injury as a result of falling or damaging boilers fixings and fixtures that may result in catastrophic failure.



Installation.

The installation must be performed by fully qualified engineers in accordance with current regulations at the time of installation.



Cleaning.

Make sure to isolate the main power supply to the boiler before cleaning. Clean the outer case with a damp cloth, Do not use chemical cleaners or abrasive compounds as this may damage the surface.

1.3 GENERAL EXPLANATION

The Astro Electric Boiler range provides space heating and Instantaneous hot water for domestic or light commercial use.

The installation must be performed in accordance with current IEE Wiring Regulations, Building Regulations, Water Fitting Regulations (England & Wales) or Water By-laws (Scotland) and all relevant British Standards.

EHC will not be responsible for damages caused from improper installation and incorrect use of the appliance.

Make sure the boiler is operated as intended. Any use which does not comply with the boiler's intended purpose may cause serious injury, death or harm to the environment and the appliance.

ATTENTION; Only Qualified Engineers & Approved Service Engineers are recommended for installation and service of the product. Unqualified personnel and the use of non standard parts can be dangerous and will invalidate the manufactures warranty.

1.4 INSTRUCTIONS and BUILDING REGULATIONS

This appliance must be installed in accordance with the following instructions.

The Local Building Regulations

The Building Regulations

The Building Standards, (Scotland-consolidated) Regulations.
Local water bylaws & British Standarts - code of practice.

BS EN 12828

Heating system in buildings design for water-based heating systems.

BS EN 12831

Heating system in buildings method for calculation of the design heat load.

BS EN 14336

Heating system in buildings installation and commissioning of water based heating systems.

BS7671

Requirements for electrical installations. IEE Wiring Regulations.

BS EN 13831

Closed expansion vessels with built-in diaphragm for installation in water.

1.5 C.O.S.H.H

Materials used in the manufacture of this appliance are non-hazardous and no special precautions are required when fitting or servicing this appliance.

1.6 PREPARATION

1.6.1 Load Check

A load check should be taken into consideration when installing high output boilers.

1.6.2 Boiler Location

The boiler must be installed onto a wall that will provide an adequate fixing and within an area that is not subject to frost or damp conditions.

1.6.3 Central Heating Installation

Detailed recommendations are given in BS EN 12828, BS6700 and CP 342-2

Pipes forming part of the useful heating surface should be insulated to prevent any potential heat loss or frost damage (BS 6700).

Drain valves should be fitted at the lowest point of the system pipe work in an accessible position.

Drain valves should be in accordance with BS 2879 and copper tube to BS EN 1057 is recommended.

2. INTRODUCTION

2.1 APPEARANCE AND EXTERNAL DIMENSIONS

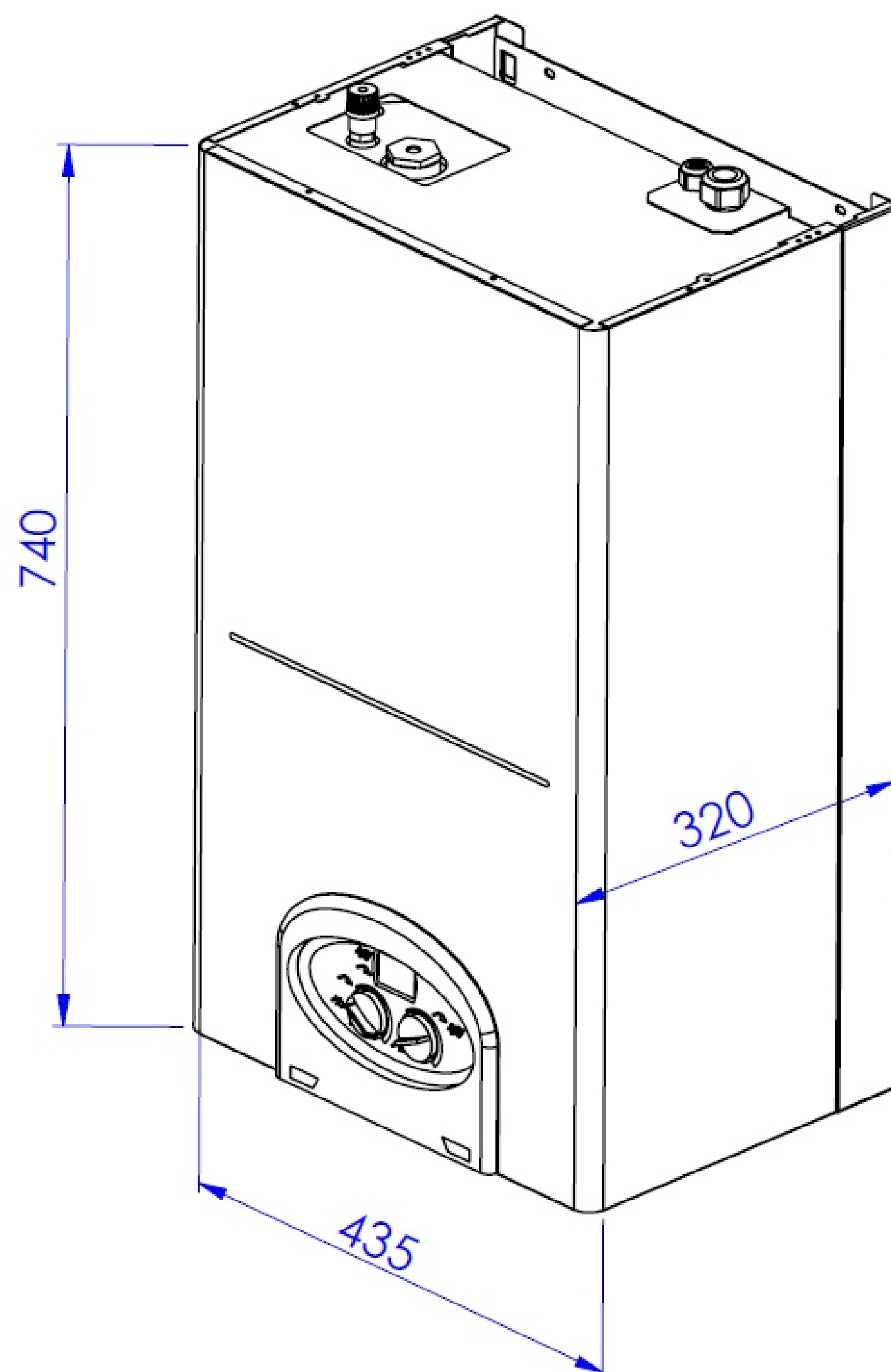

2.2 BOILER COMPONENTS

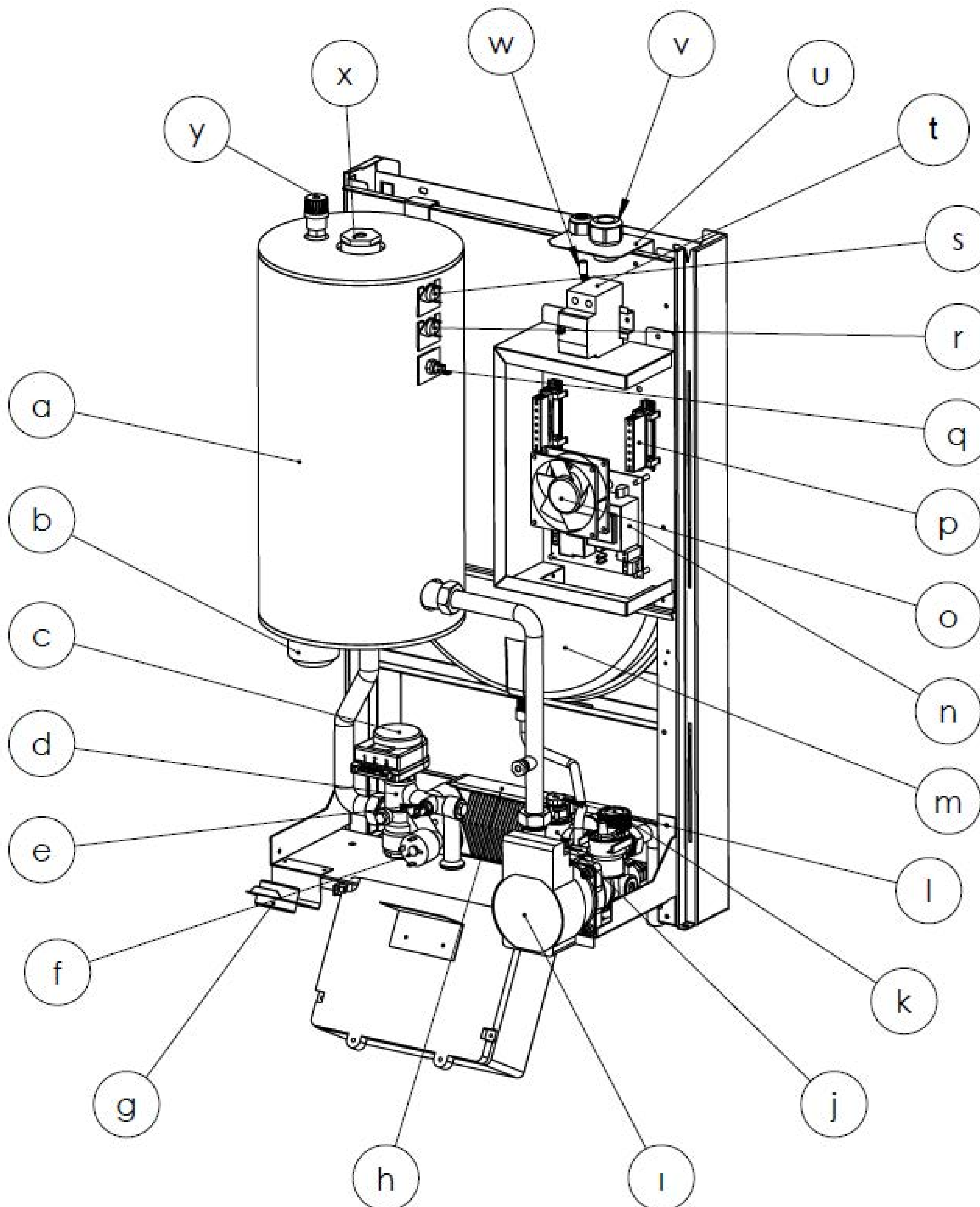

- | | |
|-------------------------------|-----------------------------|
| a. Main heat exchanger | n. PCB Control board |
| b. Heating elements | o. Cooling fan |
| c. Actuator Valve | p. Electric terminal |
| d. Flow manifold | q. CH - NTC sensor |
| e. DHW temperature NTC sensor | r. Short-circuit thermostat |
| f. Pressure switch | s. Limit thermostat |
| g. Pressure gauge | t. RCD device |
| h. Plate heat exchanger | u. Cable gland fixing plate |
| i. Circulation pump | v. Cable gland |
| j. Return manifold | w. Earth connection |
| k. 3bar safety valve | x. Float level sensor |
| l. Electronic flow sensor | y. Manual air vent |
| m. Expansion vessel | |

2.3 MAIN FEATURES OF THE BOILER

EHC Fusion Astro electric combination boilers provide central heating by connecting to panel radiators or underfloor heating systems. The primary circuit is heated via the main heat exchanger within the boiler and circulated throughout the system by the smart modulating pump. Fusion Astro boilers provide instantaneous domestic hot water to supply sinks, wash hand basins & showers within the property.

The DHW is supplied via the boilers plate heat exchanger. When there is a demand for DHW, the 3 - Way valve is activated firing the system to provide instant Hot Water to the outlets. In Winter mode, DHW supply is always prioritized.

Note: Due to lower flow rates produced from electric combination boilers, we do not recommend lower outputs boilers to fill baths. We also recommend the use of low flow tap outlets that will in turn save water and energy. Flow rates are shown in the table on page 27.

- EHC Fusion Astro electric combi boiler uses electricity as fuel.
- The device is equipped with many safety functions to provide risk free operation.
- Efficiency 100%
- Eco-friendly, Zero emissions
- Quiet operation
- Digital control system
- Error code system
- 3 Bar Internal safety valve.
- Pressure Gauge
- Energy efficient ErP Smart pump.
- S/Steel Plate DHW heat exchanger
- Low pressure protection (min 0.7 bar)
- Built-in RCD (short circuit relay) provides electrical protection.
- Internal automatic by-pass system.
- Volt Free Programmer / Thermostat connection.
- NTC Electronic water temperature control system.
- Overheat Limit Thermostat
- Short-Circuit thermostat for increased protection.
- Pump Protection -Anti- Seizure system will operate the pump every 24 hours to prevent it from sticking when not used for long periods.
- Frost protection.
- Boiler outputs: 12,15,18 & 24kW

3.MOUNTING AND INSTALLATION

3.1 OPENING THE BOX

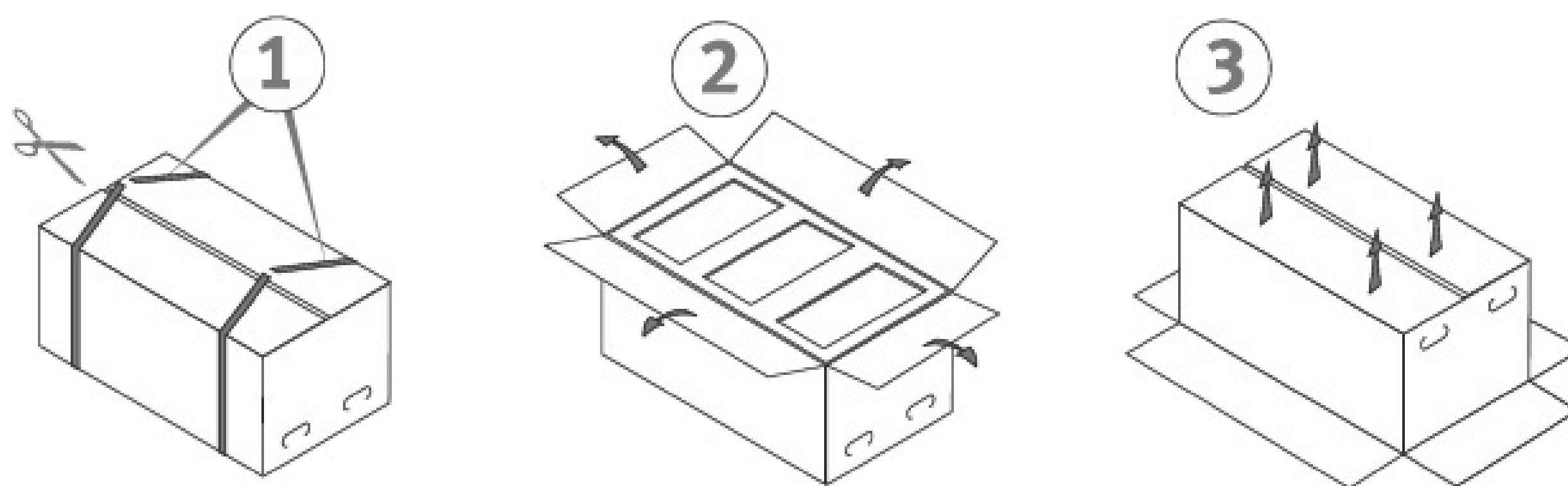

Open the box as shown above . Cut the cord or remove the staples, fold the box lids backward and turn the box upside down onto a protected surface. Pull the box upwards and remove.

QTY	DESCRIPTION
1	Electrical Combi Boiler
1	Wall Mounting Plate
1	Documents Pack
4	10x50 Wall Plug
4	M7x50 Screw

Note: Care must be taken when opening and removing the boiler from its packaging to prevent any damage.

Handling:

It is advised that two people carry and mount the boiler onto the wall using all relevant safety precautions and protective clothing, foot wear,gloves and goggles must be worn when appropriate.

3.2 MOUNTING INSTRUCTIONS

The Boiler must not be installed in Humid/Damp areas such as bathrooms or buildings that are open to the atmosphere. The location should be clean and dry with no presence of gases,explosives,flammable materials or chemicals of any kind.

The boiler must be mounted on a wall capable of carrying the boilers full weight when fully commissioned (42kg). When the boiler is fixed onto Masonry walls, use the supplied screws and plugs. When the boiler is fixed onto other wall types e.g. plasterboard walls, it is recommended that the boiler is secured onto the timber studs to provide a secure fixing. You can use the supplied screws and disregard the wall plugs for this type of installation.

Take care when mounting the boiler that you leave the recommended clearances shown below. This is important for any future maintenance of the unit and required ventilation.

3.3 MINIMUM CLEARANCES

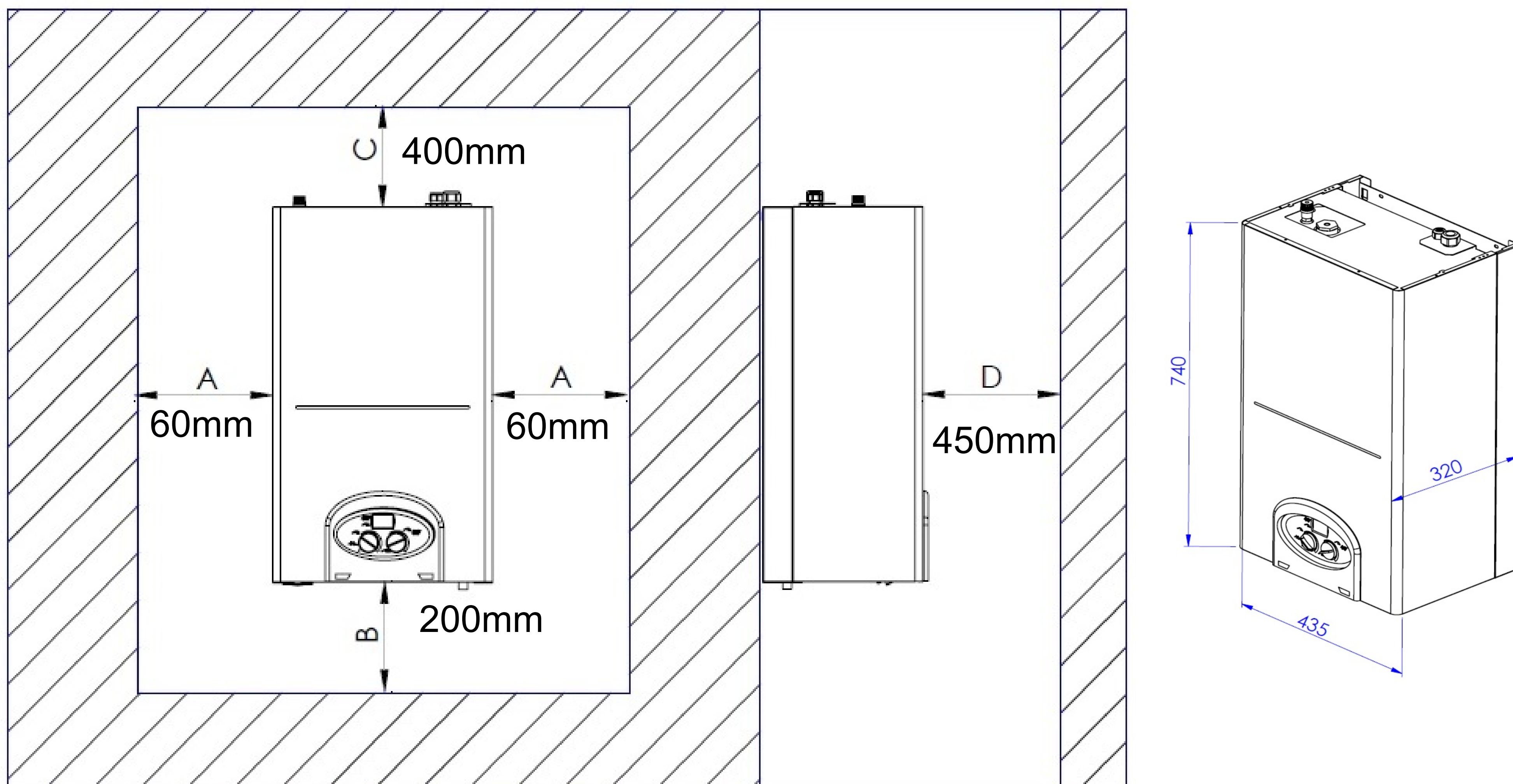

3.4 WALL MOUNTING

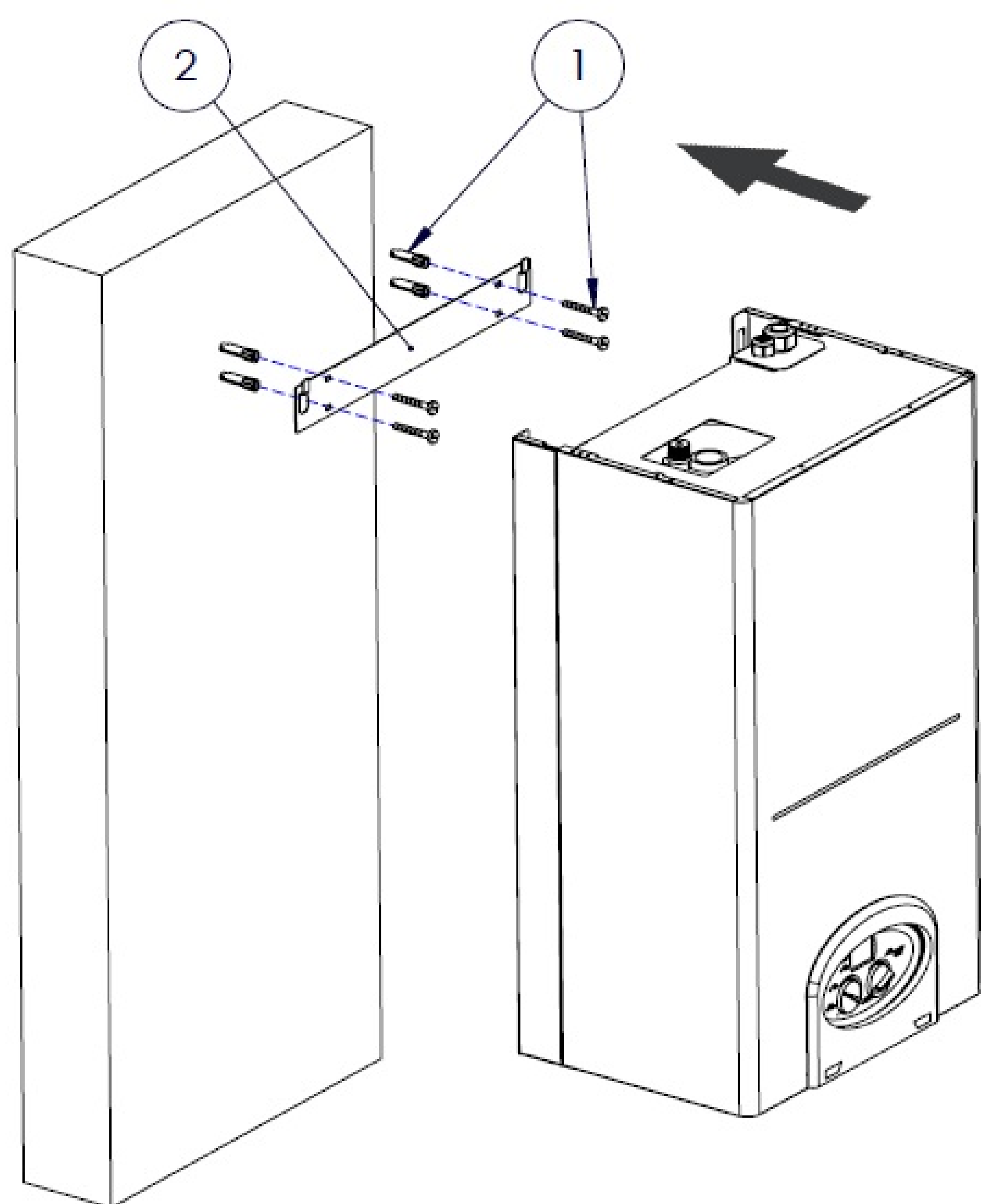

1. Hold the mounting plate against the wall at your chosen height parallel to the floor taking into consideration the minimum required clearances and level with a spirit level.
2. Mark the holes.
3. Drill and insert the provided wall plugs.
4. Now fix the mounting plate using the screws and plugs provided.
5. Hang the boiler on the mounting plate.

Note:

The boiler will be approximately 12mm higher than the mounting plate when installed. If the boiler is to be mounted onto a plasterboard wall the plate must be fixed directly onto the timber frame behind the plasterboard to ensure the unit has a secure fixing.

3.5 HEATING AND HOT WATER CONNECTIONS

- **Cold & Hot Water Connections.**

The cold water inlet and hot water outlet connections are G 1/2" male thread connections. Use 2 x 1/2" female to 15mm pipe adapters with an isolation valve fitted to the cold supply connection. Make sure that the pressure of the mains water does not exceed 6 Bar. If the Mains Water pressure is more than 6 Bar a pressure reduction valve must be fitted. The minimum required pressure is 0,8 Bar. For hard water areas a water softener must be used. Salt softeners must not be used to fill the heating system.

Note:

Set the correct flow rate for the boiler output as shown in the table on page 27. If the flow rate is set to high the Hot Water outlet temperature will not be achieved.

- **Flow & Return Connections.**

Flow & Return connections are G 3/4" male thread. Use 2 x 3/4" female to 22mm pipe adapters along with 2 x full bore isolation valves to provide good system circulation. A minimum of 1m of copper pipe must be used on all connections from the boiler. The boilers are fitted with Wilo smart pumps that can be adjusted if required. Refer to the pump section below. An external magnetic filter must be used on all installations.

- **PRV.**

The boilers are fitted with a 3bar pressure relief valve that will automatically activate if the system pressure is ever increased above 3 bar. The PRV should never be used as a drain point as this could cause the device to leak.

- **Bypass.**

When thermostatic valves are used and close due to the room temperatures being achieved the boilers internal bypass will operate. The automatic by-pass system will provide the minimum circulation requirement for the heat exchanger.

- **Insulation.**

We recommend that all pipe-work is insulated where practical. Especially the primary pipe-work with in a boiler cupboard. This will reduce heat loss and protect the cupboard from high temperatures.

- **System Filling.**

A WRAS approved filling loop must be used and installed in such a way that it never becomes a permanent connection to the mains water and the heating system itself. The heating system should be filled to 1.5 bar when cold and topped up accordingly during commissioning and general system maintenance.

- **Connections**

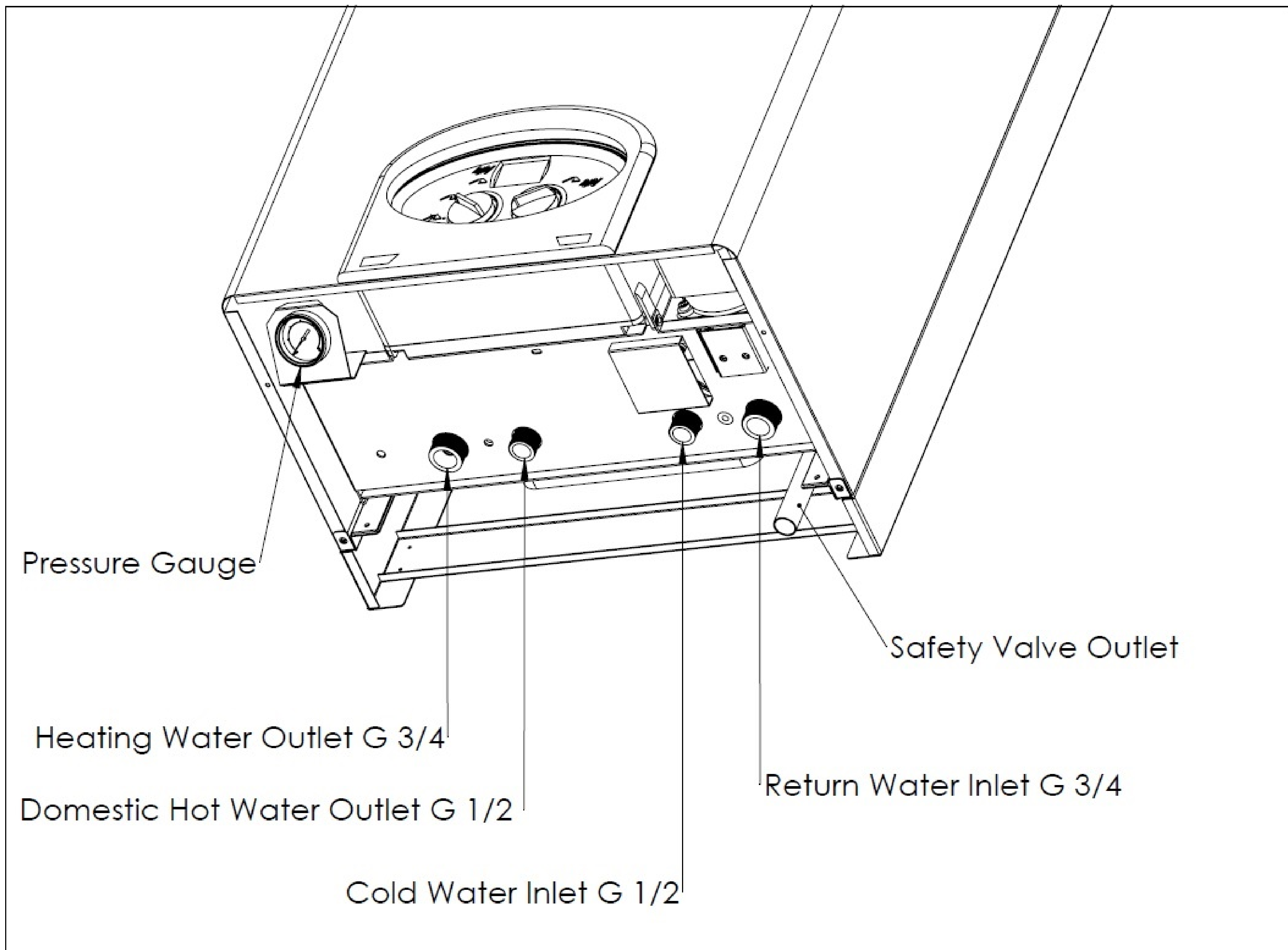

- **Flushing.**

- The primary circuit must be flushed in accordance to BS 7593. The system must be flushed to within 10% off mains water PPM to ensure that no debris is trapped in the system.
- Failure to do so may lead to boiler failure which will not be covered by manufacturer's warranty.
- Where existing radiators and pipe-work are used, a power flush must be carried out and a magnetic filter installed.

- As per the instruction, use F1 Protector and F3 Cleaner for our systems.
- We recommend F1 Protector and F3 Cleaner for our systems.



If you require further assistance, please contact our technical support team on 03301007750 or Technical 0870 870 0362.

3.5.1 BOILER INSTALLATION SCHEMATICS

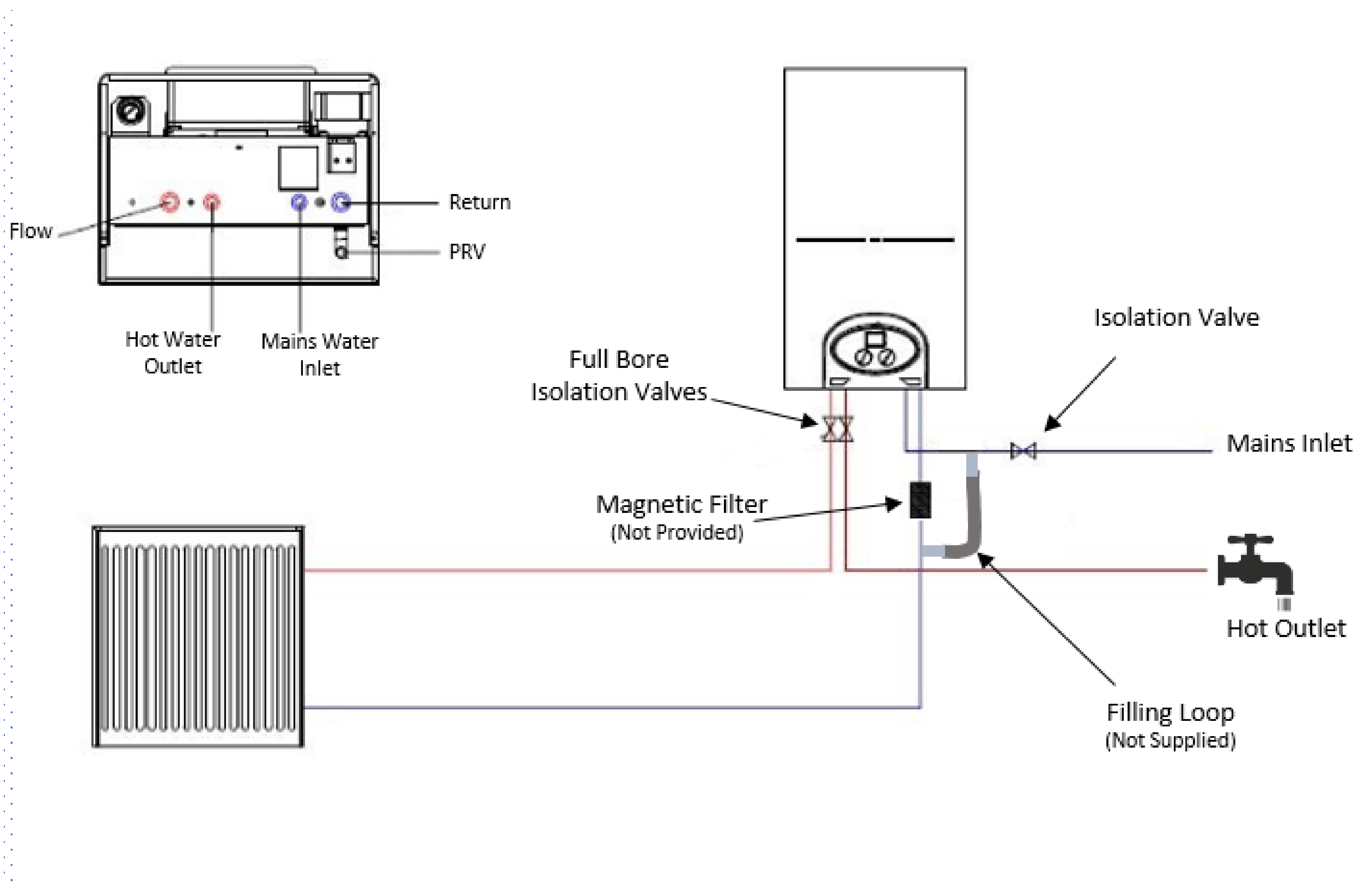

3.5.2 CIRCULATION PUMP INFORMATION

Indicator Lights (Leds)

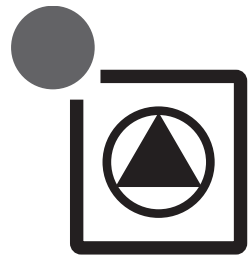

- Signal display
- LED is lit up in green in normal operation
- LED lights up/flashes in case of fault

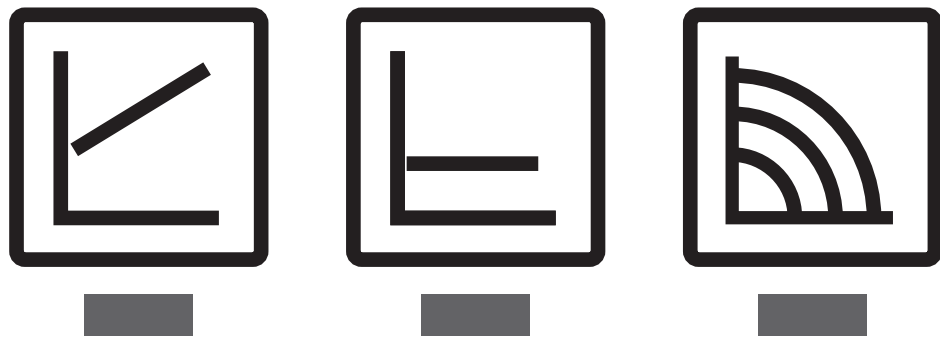

- Display of selected control mode p-v, p-c and constant speed

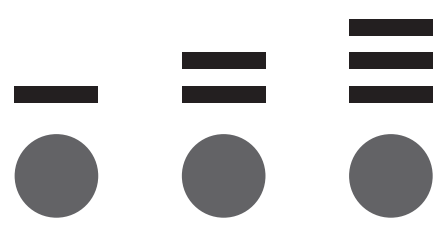

- Display of selected pump curve (I, II, III) within the control mode



- LED indicator combinations during pump venting function, manual restart and key lock

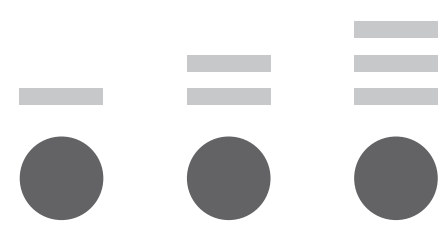

Operating button

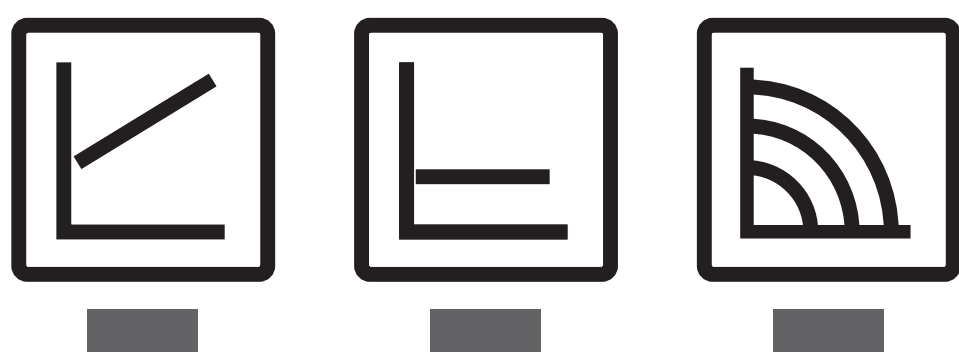

Press Button

Select control mode

Select pump curve (I, II, III) within the control mode

Press and hold

Activate the pump venting function

(press for 3 seconds)

Activate manual restart (press for 5 seconds)

Lock/unlock button (press for 8 seconds)

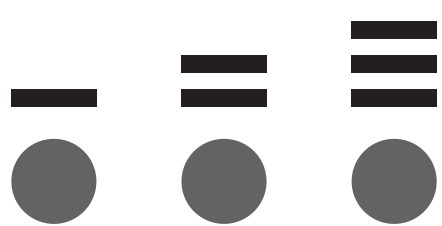
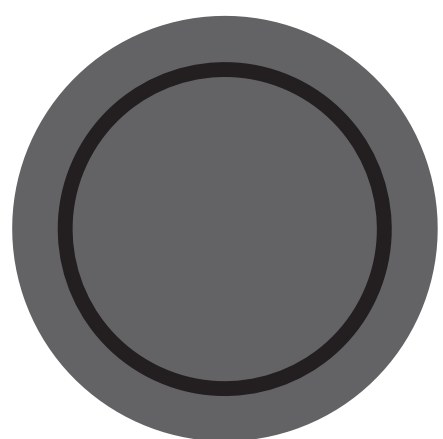

Control modes and functions

Variable differential pressure $\Delta p-v$ (I, II, III)

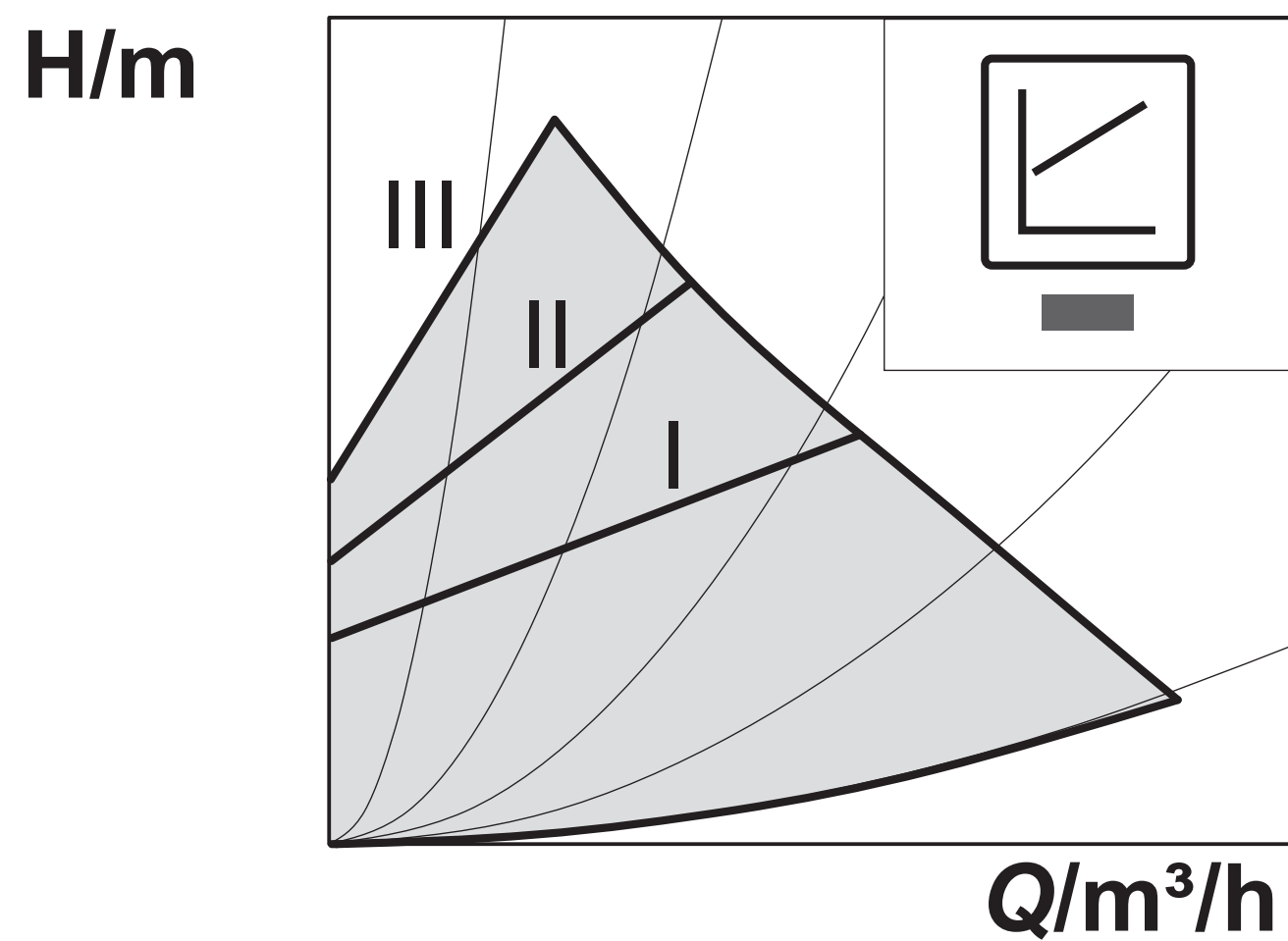

Recommended for two-pipe heating systems with radiators to reduce the flow noise at thermostatic valves.

The pump reduces the delivery head to half in the case of decreasing volume flow in the pipe network. Electrical energy saving by adjusting the delivery head to the volume flow requirement and lower flow rates. There are three pre-defined pump curves (I, II, III) to choose from.

Constant differential pressure $\Delta p-c$ (I, II, III)

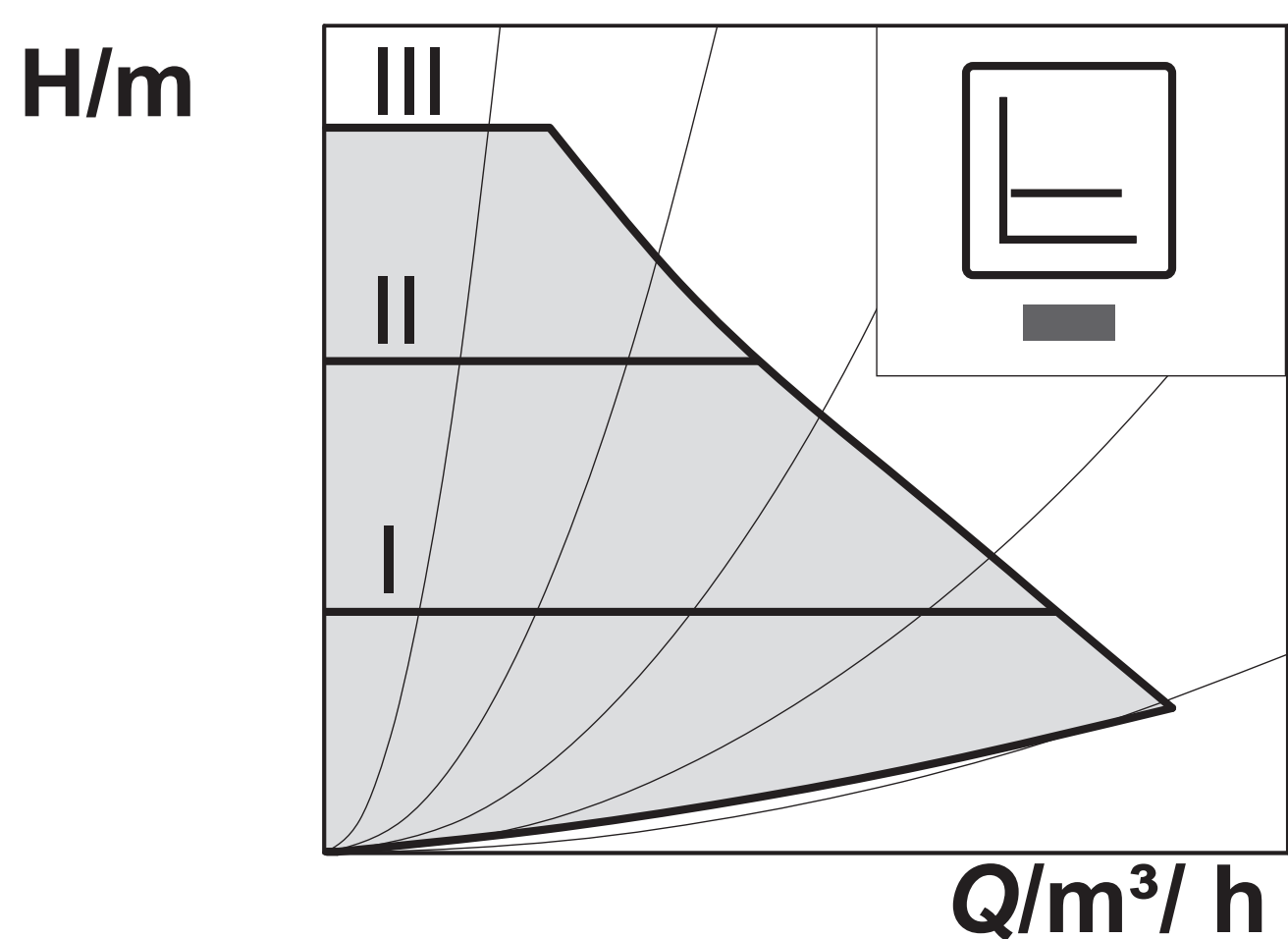

Recommended for underfloor heating or for large-sized pipes, applications without a variable pipe network curve (e.g. storage charge pumps) or single-pipe heating systems with radiators.

The control keeps the set delivery head constant irrespective of the pumped volume flow. There are three pre-defined pump curves (I, II, III) to choose from.

Constant speed (I, II, III)

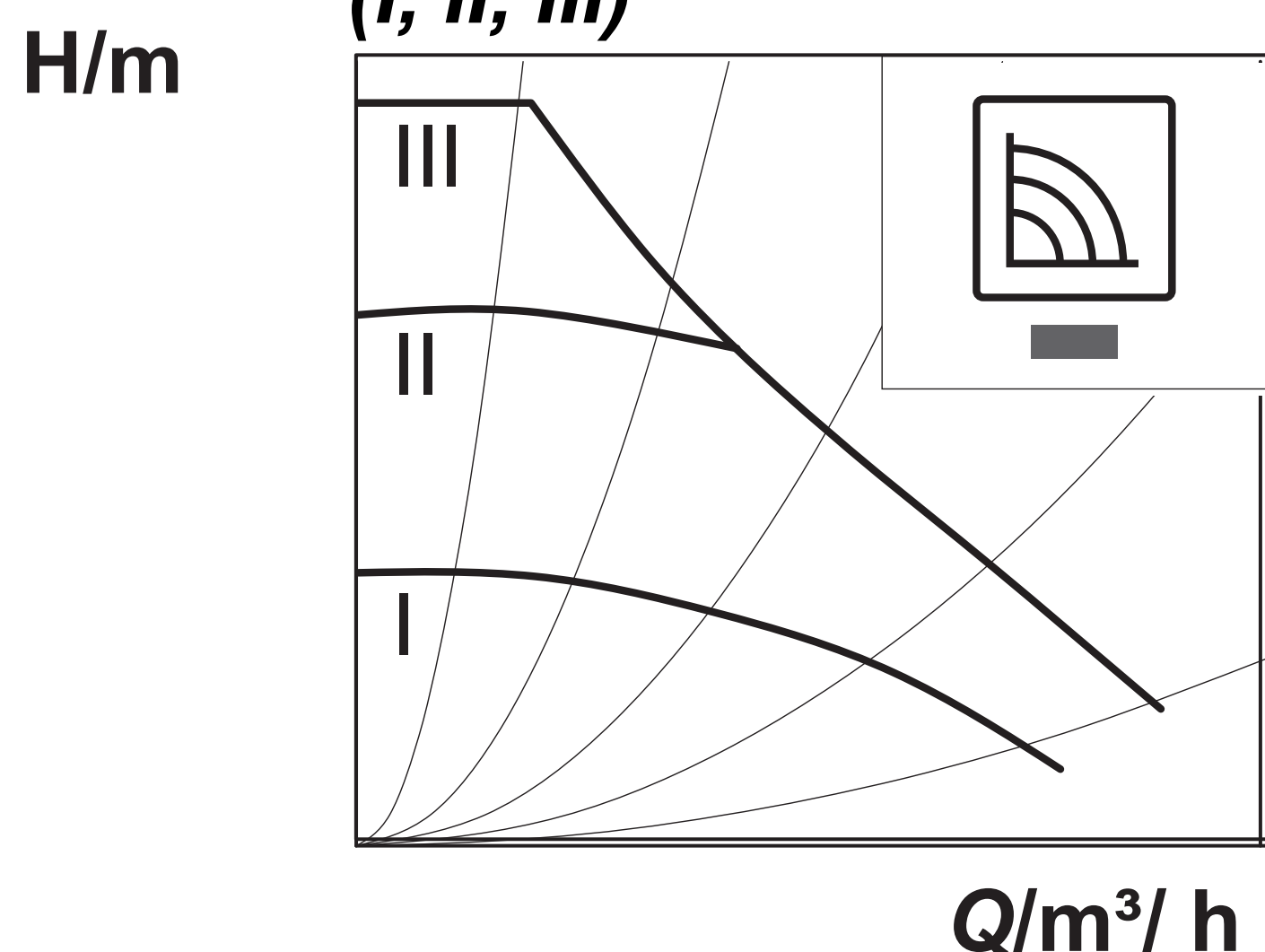

Recommended for systems with fixed system resistance requiring a constant volume flow. The pump runs in three prescribed fixed speed stages (I, II, III).

Control modes and functions

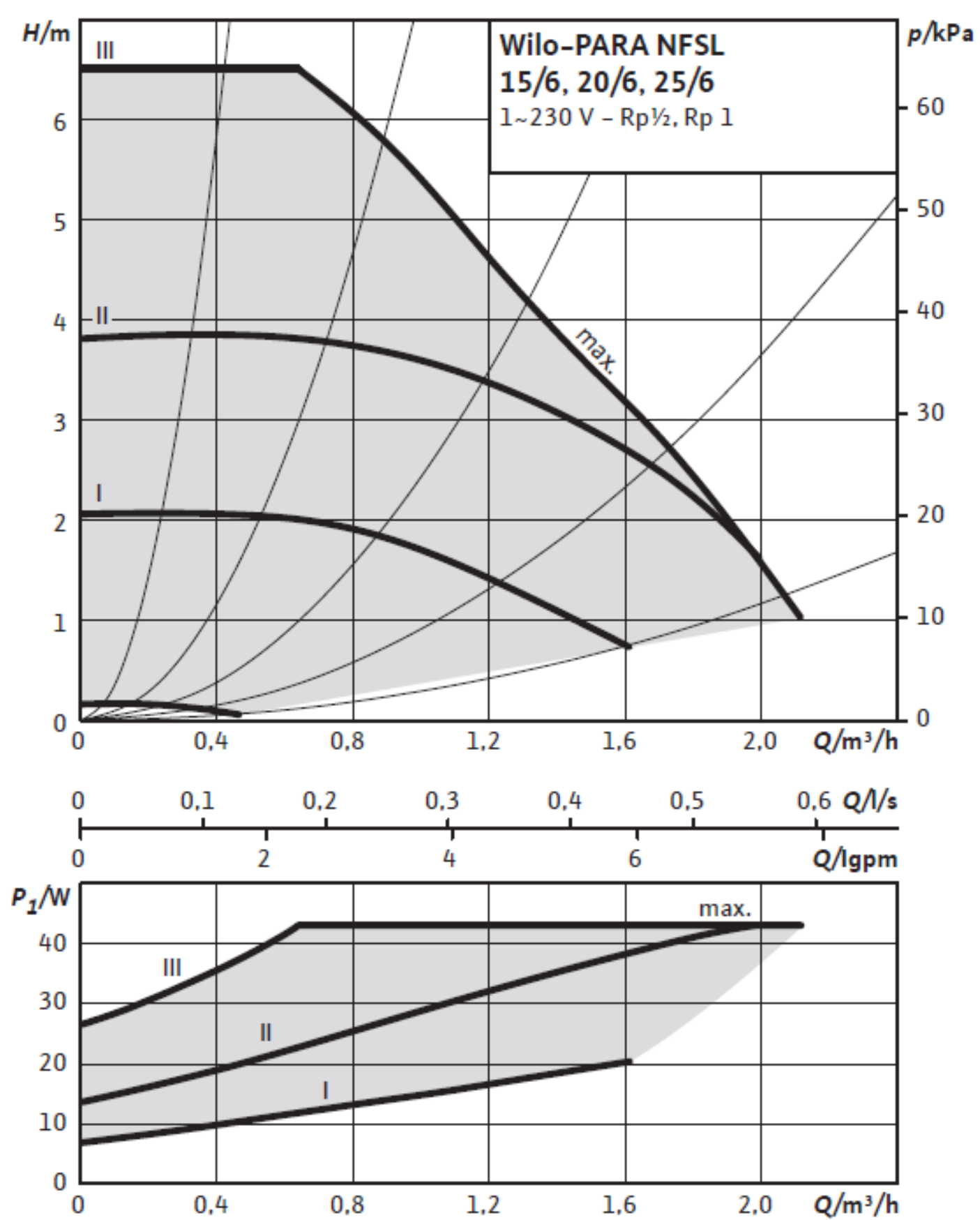
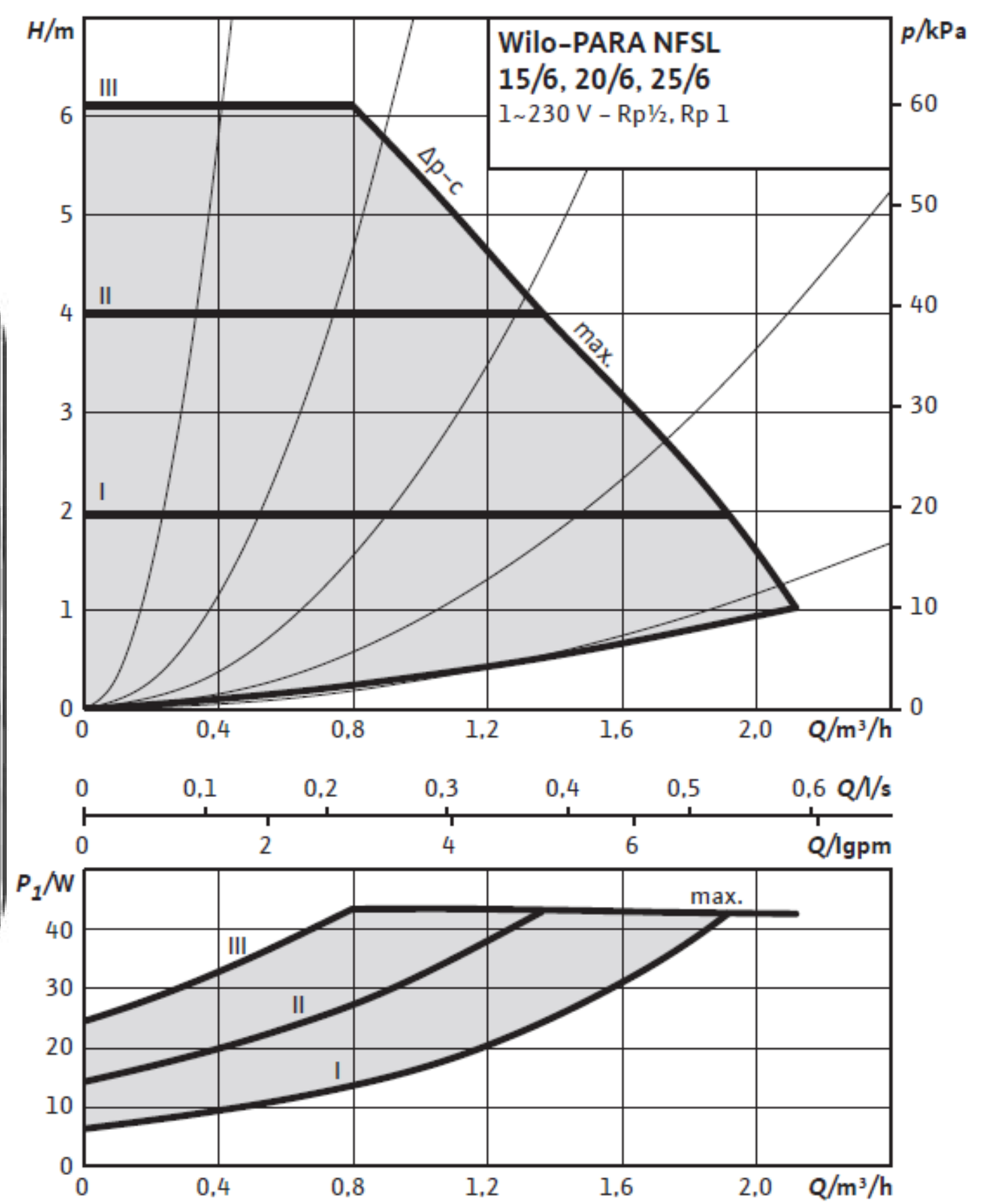
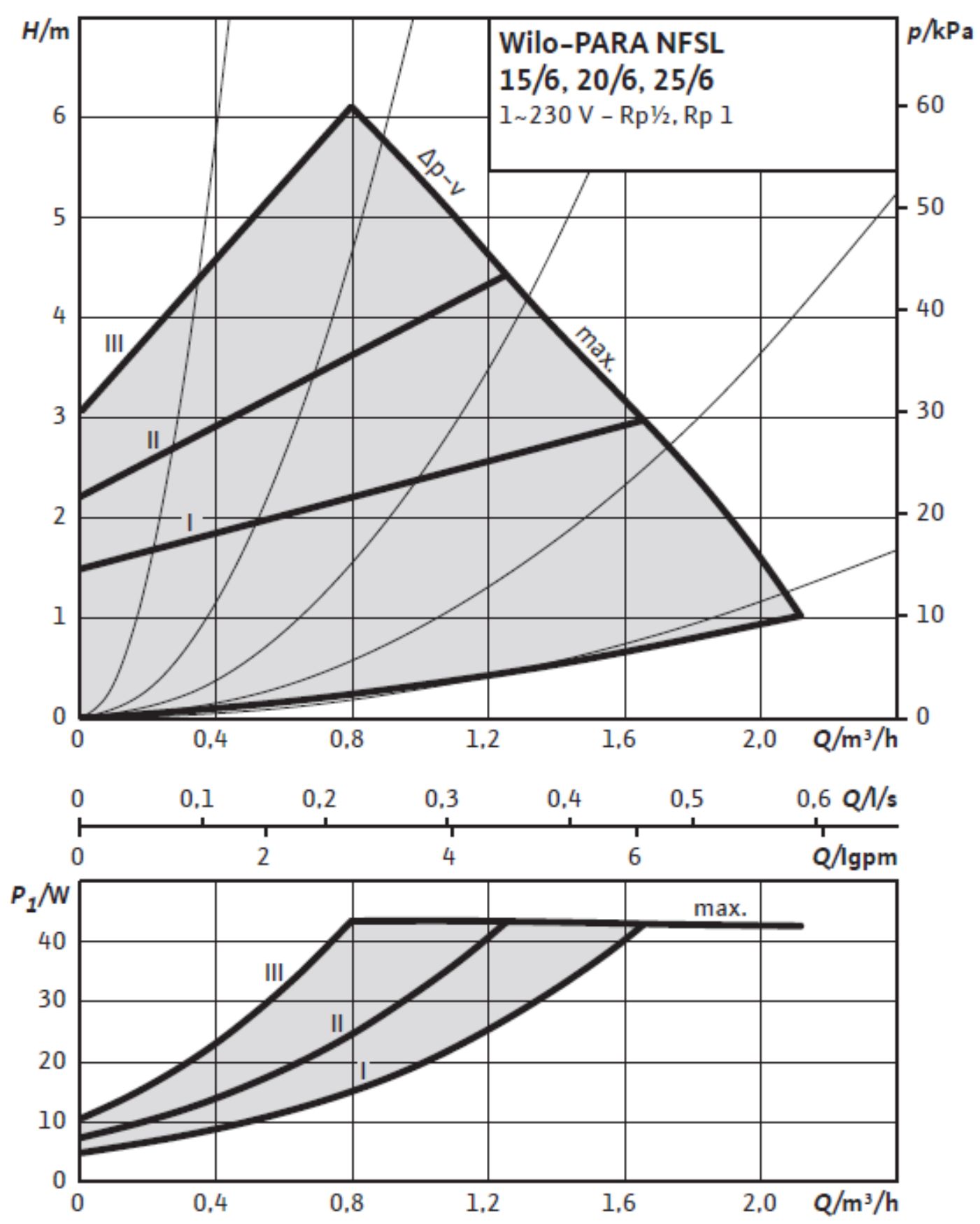

3.6 ELECTRICAL CONNECTIONS

All electricity connections to the boiler must be made by a fully qualified electrician. Improper electric connections made by unqualified people may cause failure of critical components of the boiler and will invalidate the warranty.

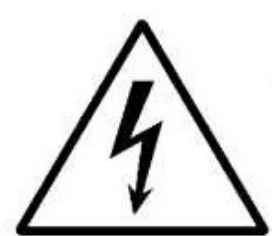

DANGER ! Electric Shock Risk

- Make sure to isolate the main power supply before starting work on the boiler.
- Secure the main energy supply to prevent from turning on while working on the boiler.

3.6.1 Electricity Connection Precautions

- We recommend that a load check is carried out when installing high power boilers.
- All electrical connections must be made by a fully qualified electrician.
- All wiring must be carried out in accordance with current IEE BS7671 wiring regulations.
- An upgrade to the main fuse of the property may be required.
- This appliance requires supplementary earth bonding across all pipes connected to the boiler and the main earth terminal within the boiler.
- Surge protection devices should be installed within the installation in-line with regulation 443 of BS7671.

3.6.2 Removing the Front Boiler Cover

To make electrical connections remove the front cover as shown below.

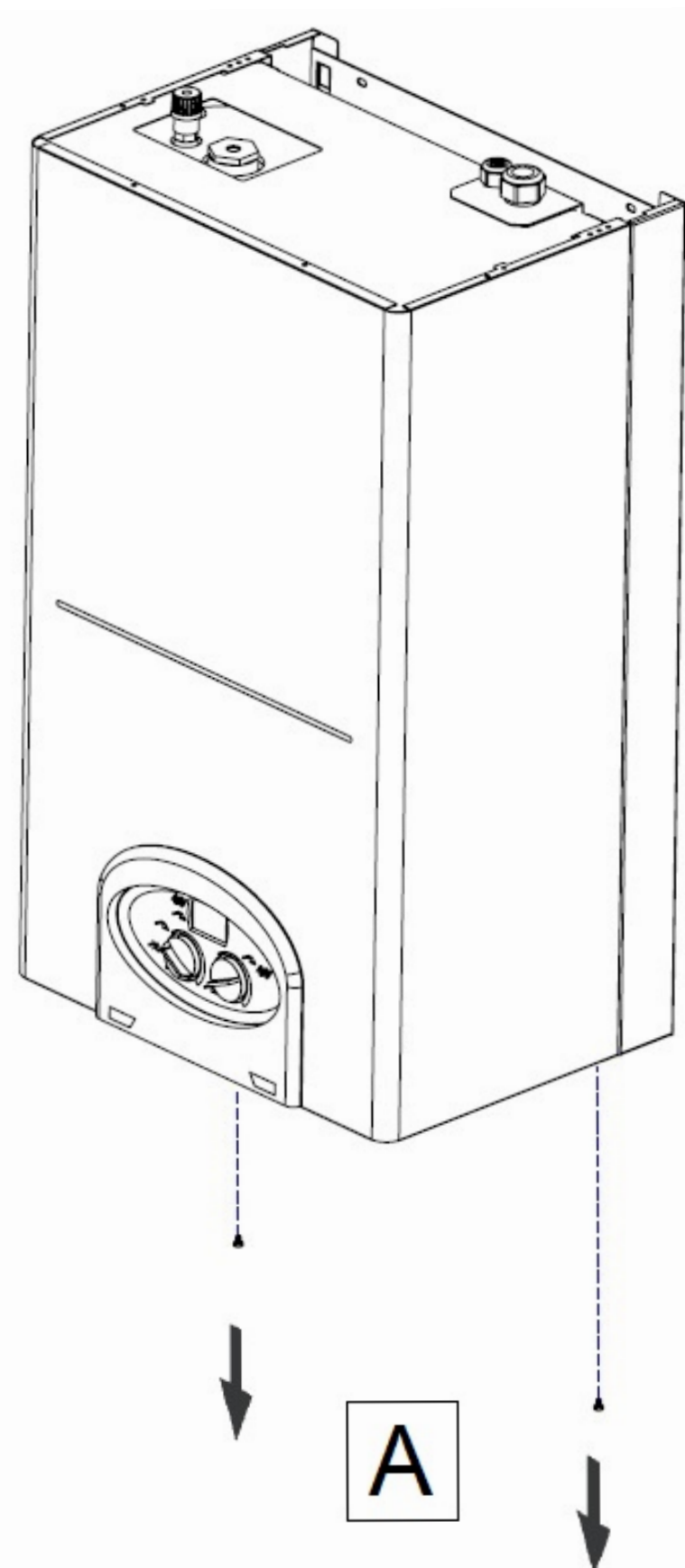

- A) Remove the 2 bottom screws of the front boiler cover.
B) Slide the boiler cover upwards until its released from the boiler chassis.
C) Pull the front boiler cover towards you to disassemble.

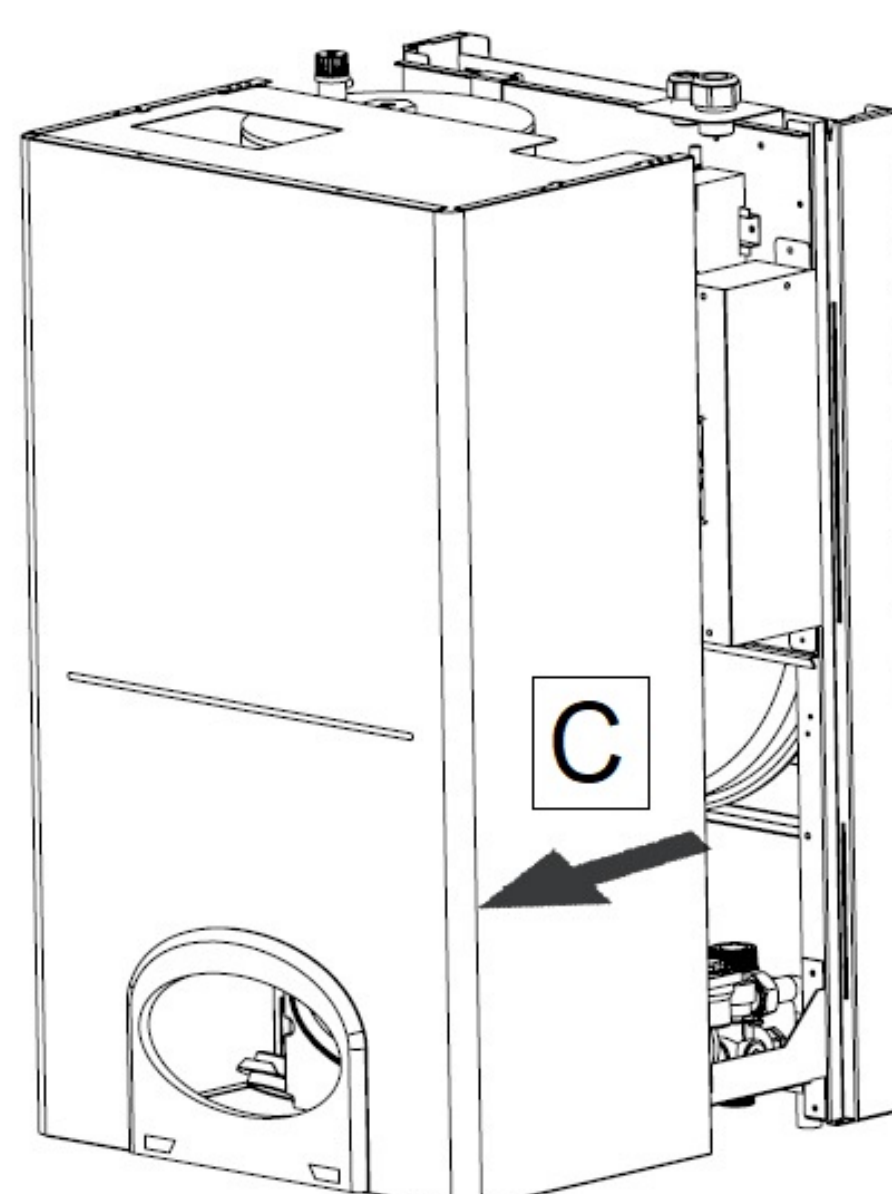
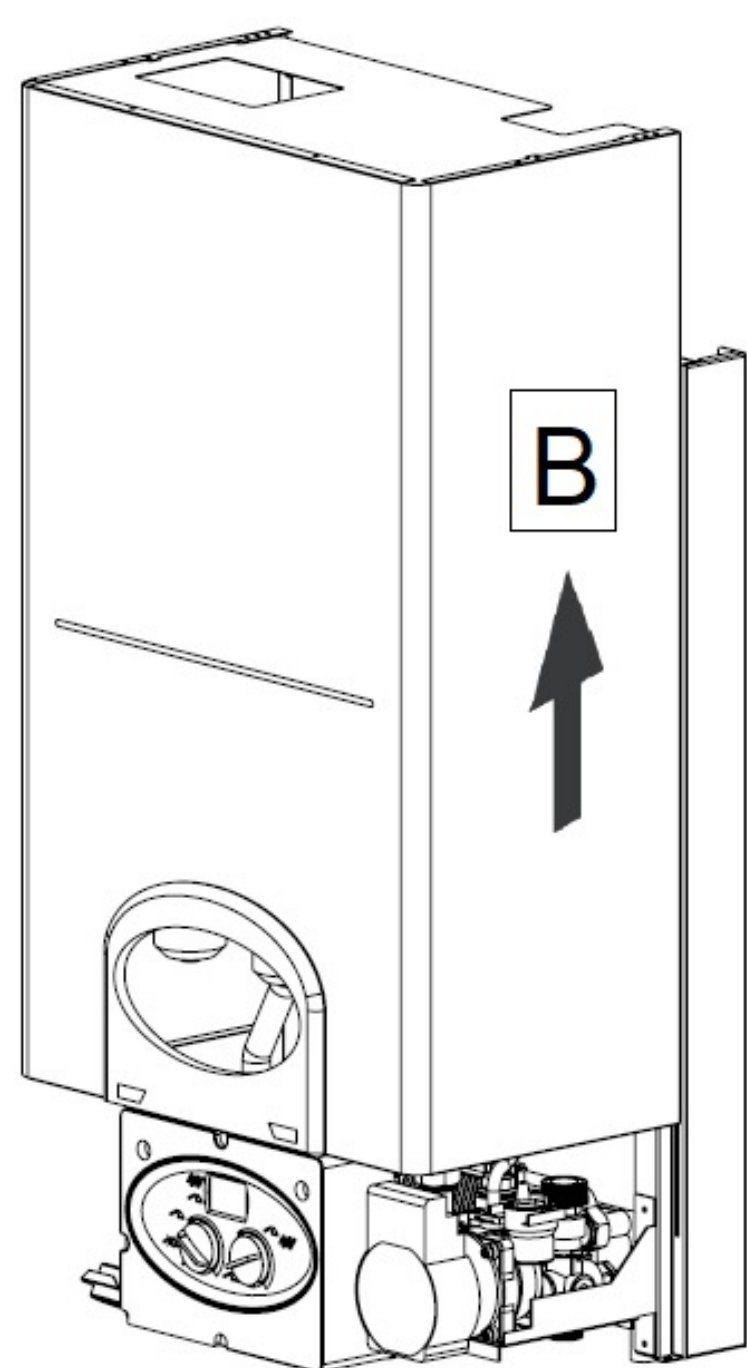

Always isolate the main power to the unit before removing the front cover..

3.6.3 Electrical Supply Connections

The main electricity supply connection must be made according to the minimum cable sizes indicated on the boiler technical label.

The connections are made to the RCD device according to the diagram below.

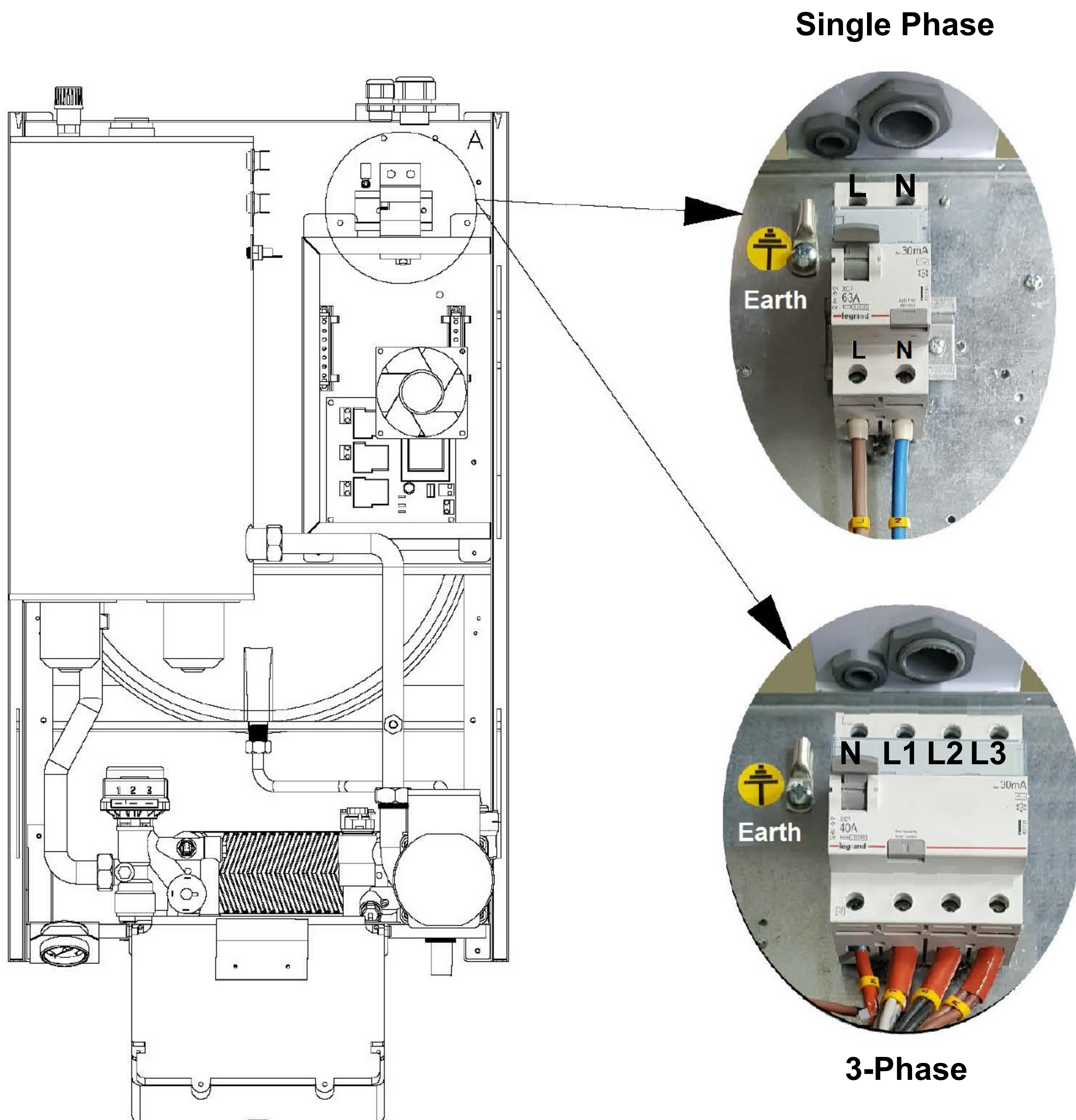

The cable connections are clearly marked on the cables connected to the RCD device.

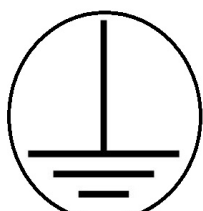
- Single Phase L N
- 3-phase N L1 L2 L3
- Earth connection is marked with 



WARNING

- Make sure that the power supply cables are tightened between 2.8 -3.5 Nm torque onto the RCD device. Loose connections are dangerous and can cause fire.
- Do not operate the boiler without an earth connection. Use the correct cable size and connect it to the earth connection within the boiler.
- Feed the supply and control cables through the glands at the top of the boiler and tighten. Where SWA cable is used the plastic gland should be replaced with a brass SWA gland.

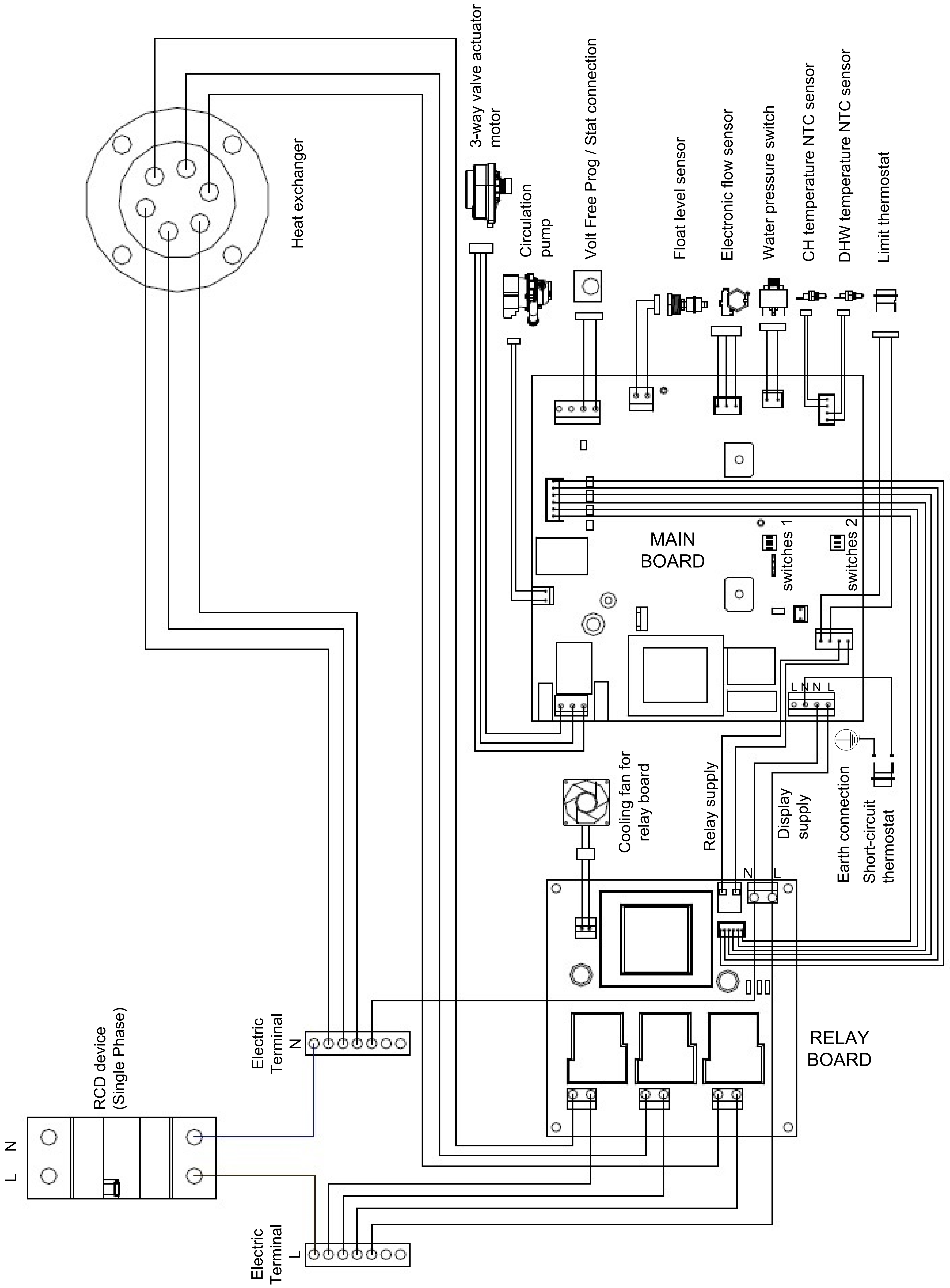
3.6.4 Electrical Connection Diagram 230V (Single Phase)

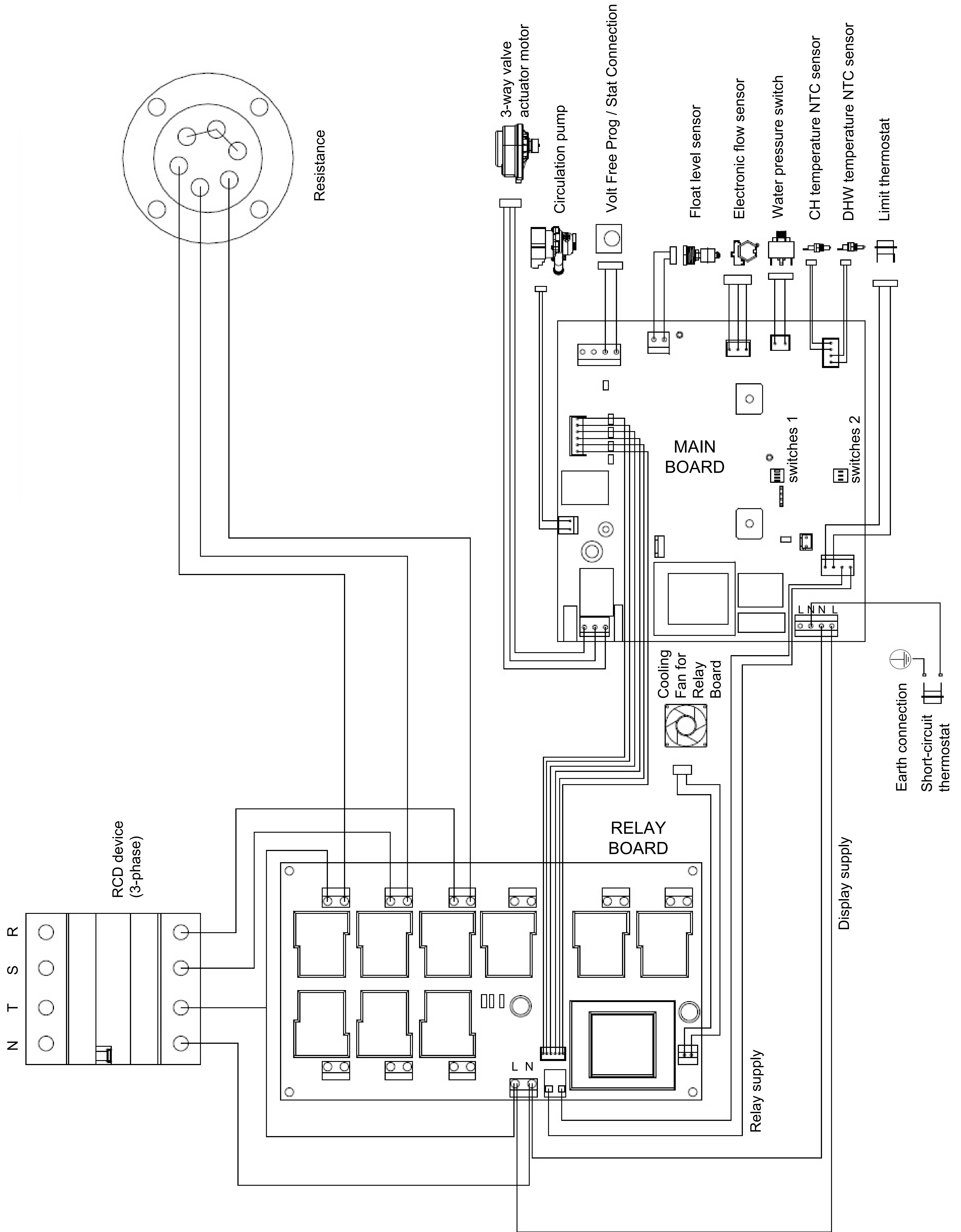

3.6.5 Electrical Connection Diagram 400V (3-phase)



3.7 MAIN PCB DIP SWITCH SETTINGS

The universal main board of the boiler is designed to be suitable for all types of Fusion Astro boilers. Make sure to adjust the switch positions on the main board according to the boiler type while replacing the mainboard in case of a failure. The switch positions are explained below.

3.7.1 Switches 1

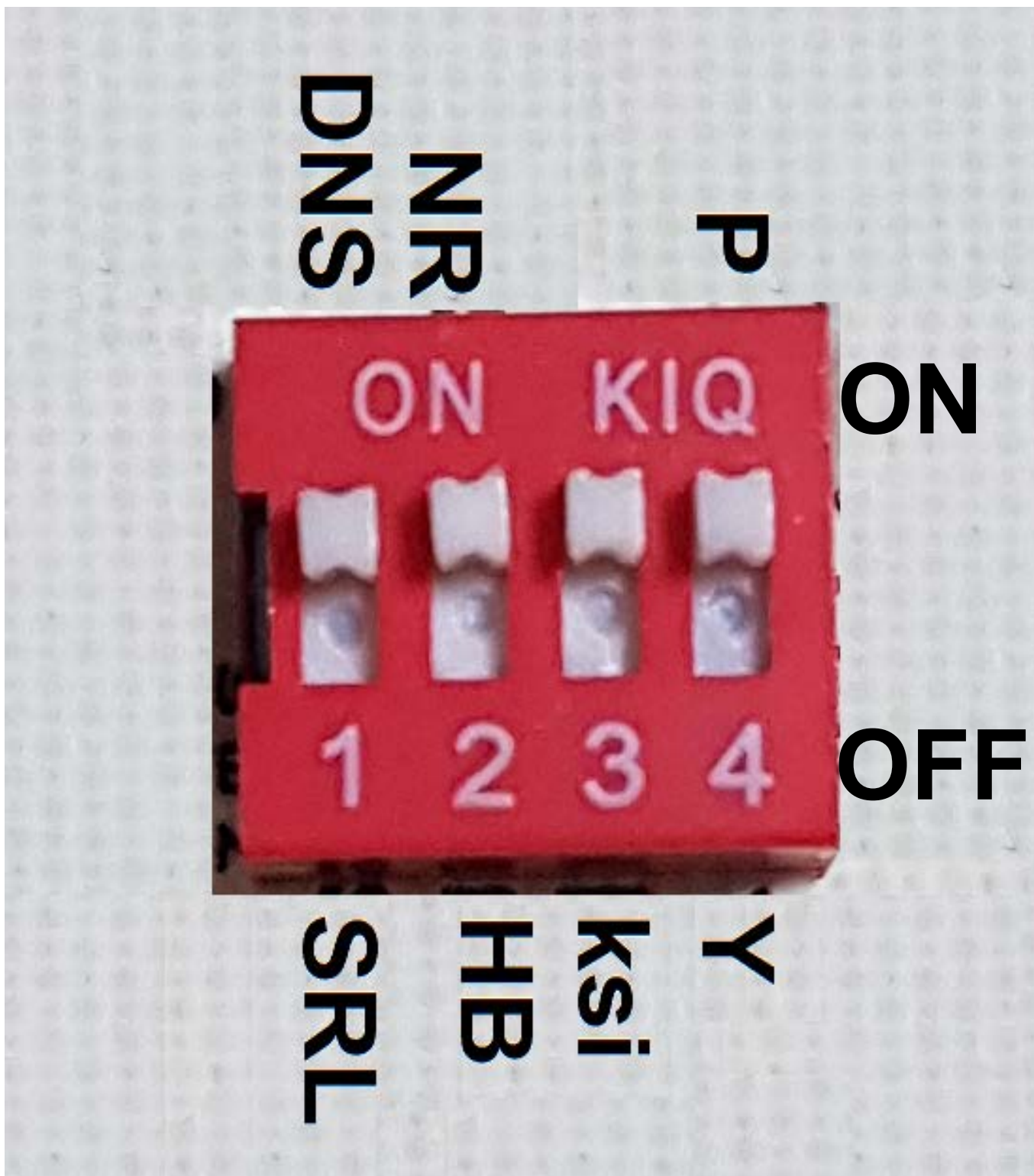

- 1) On: Electrical Cycling increases the life span of the elements within the heat exchanger. Off: Heating elements operate in constant order
- 2) On: Instantaneous DHW supply via plate heat exchanger (Factory Default Do Not Change)
- 3) On: Heating & DHW
Off: Heating Only (No DHW)
- 4) On: Standard Heating Temperatures (30-80)
Off: Underfloor Heating Temperatures (20-40)

3.7.2 Switches 2

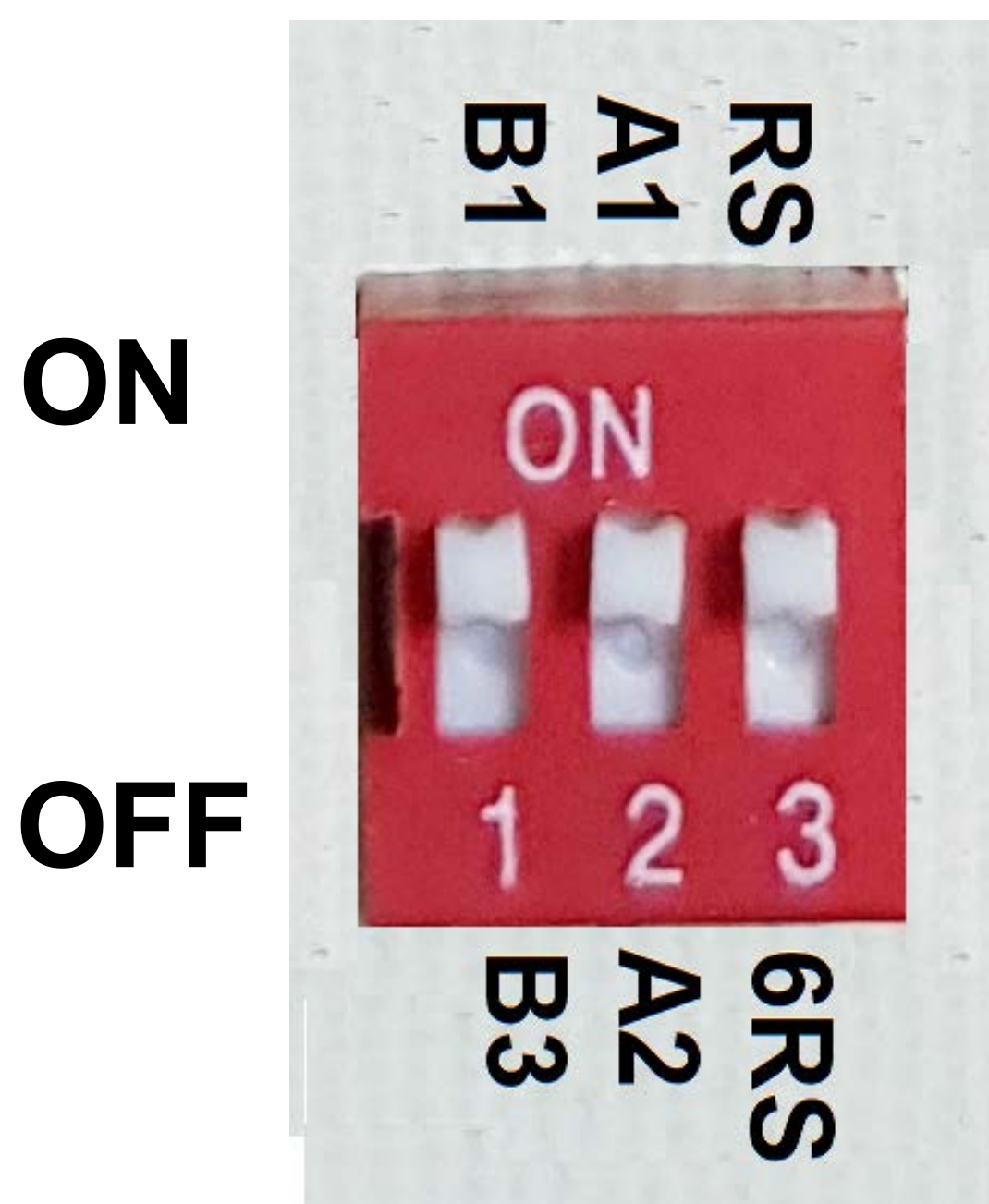

- 1) Empty (no function)
- 2) On: 3 and 9 relay boards.
Off: 12 relay boards.
- 3) On: 3 and 9 relay boards.
Off: 6 relay boards.

3.8 PROGRAMMER / THERMOSTAT CONNECTION

Within the boiler there is a terminal that is located at the top of the unit next to the main power connections.

This is where your Volt Free external control cable should be connected.

Remember to remove the link before connecting your external Volt Free control cables. We recommend using an EHC single channel heat pack that includes a wired programmer and room thermostat, alternatively a wireless thermostat can be used.

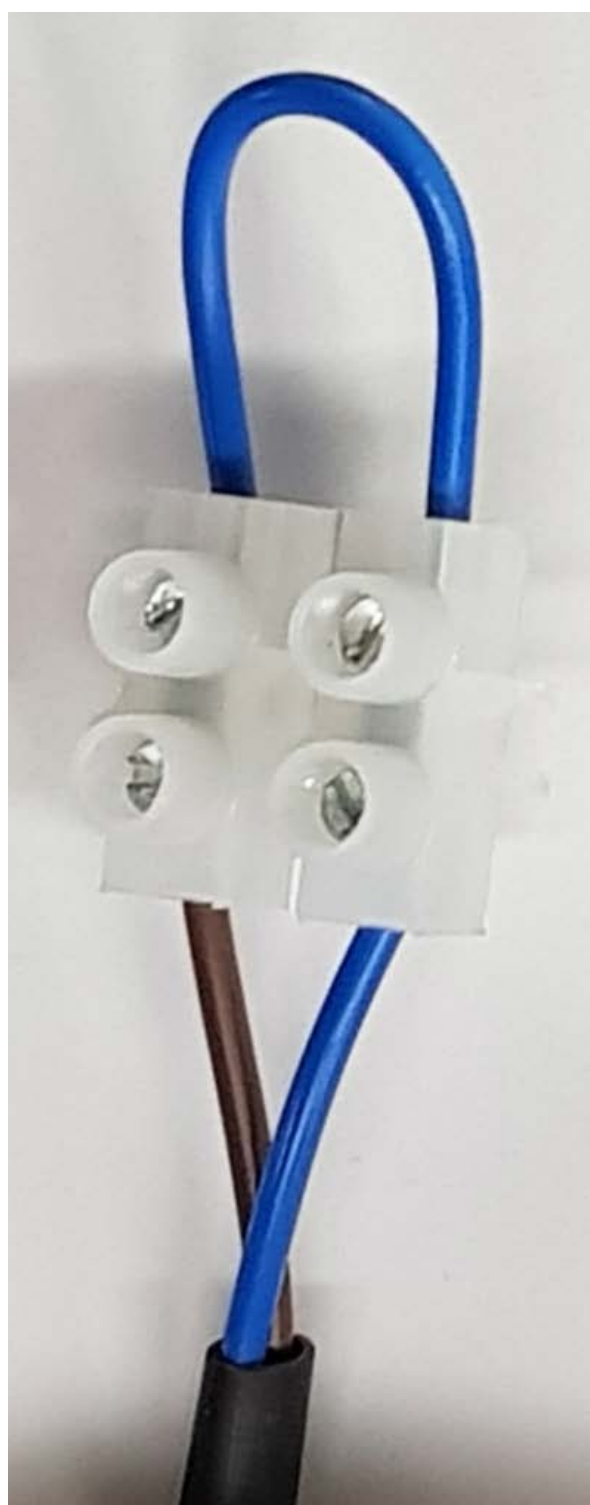

WARNING!

- Do not connect any voltage to this terminal as this will damage the boilers electronic control system and will invalidate the warranty.

3.9 ELECTRICITY CONNECTION PARAMETERS

Electrical		12kW	15Kw	18kW	24kW
Supply Type		1Ph	1Ph	3Ph	3Ph
Minimum Cable Size	mm ²	16	16	5x6	5x6
Time Delayed RCD Specification	A/mA	63/30	80/30	40/30	40/30
Circuit Protective Device	Amps	63	80	32	40
Voltage/Frequency	V~Hz	230/50	230/50	400/50	400/50
Load Current	Amps	52	65	26	35
Element Resistance	ohms	13	33	27	20

4. COMMISSIONING

4.1 FILLING THE SYSTEM

- a) Connect the primary filling loop and tighten.
- b) Make sure that all primary connections are tight before filling.
- c) Loosen the automatic air vent on the pump body.
- d) Open all thermostatic valves on the radiators.
- e) Fill the system to 1,5 bar and vent.
- f) Vent the main heat exchanger using the manual air valve.

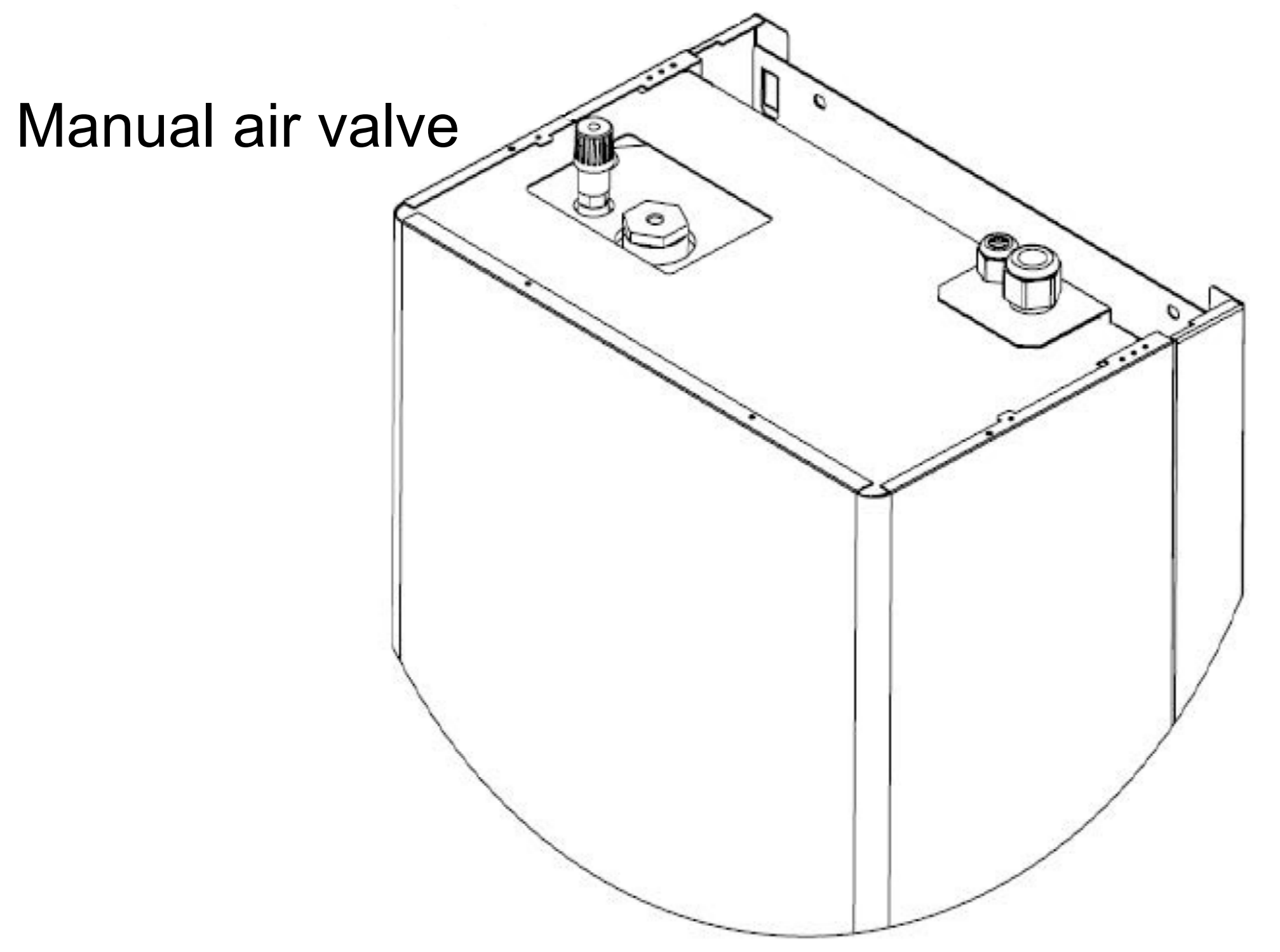

- g) Vent the radiators
- h) Check the pressure on the pressure gauge and fill up to 1,5 bars as necessary.
- i) Close the water inlet valve and disconnect the filling loop.
- j) Make sure all the connections are tight and free from leaks



CAUTION!

The primary circuit must be flushed in accordance to BS 7593 .
Make sure to undertake the below steps for system protection. Failure to protect the system will invalidate the warranty.

- a) Fill the system with cold mains water to the recommended pressure 1.5 bar and check for leaks, then drain the system thoroughly making sure all drain cocks are fully open and that the system is completely drained.
- b) Add Fernox F3 cleaner to the system at the furthest point from the boiler, this is to allow the substance to fully dilute throughout the system. If you are unsure of the correct dose rate, contact Fernox on 03301007750 for advice.
- c) Re-Fill the system and circulate the F3 cleaner prior to the boiler being fired.
Commission the system in the normal way. The cleansing agent must be in the system for a minimum 1 hour with the system running at normal operating temperature. A longer period of time would be more beneficial to the cleansing process especially if excess flux was used or is an old system. F3 cleaner can be left in the system for up to a maximum of one week running on a normal heating cycle.(We recommend that existing systems are power flushed as per BS 7593 and PAS33 regulations)

d) Drain and flush the system thoroughly to remove the cleaning agent and any debris or contaminants. This is a critical part of the cleaning process and must be carried out correctly. Use a rinse test meter (TDS), such as the Fernox CTM. The reading must be within 10% of the mains ppm value.

e) After the system has been thoroughly flushed and TDS readings are within 10% you can now add Fernox F1. This will protect against the formation of scale, corrosion and microbiological growths. It is crucial however, that for the protector to work correctly, the system must be properly cleansed and flushed.

f) Now attach the label included within the Fernox F1 packaging completed and attached adjacent to the boiler. We recommend inhibitor levels are checked on an annual basis (usually during the service) or sooner if the system content is lost. This should be carried out using a Fernox inhibitor Test Kit. Fernox Technical Service Help line on 0870 870 0362 for further assistance.

4.2 STARTING UP

Note: The boiler must be commissioned by a fully qualified engineer.

- a) Check that all radiator valves are open and the radiator / heating circuits are free from air. (The system pressure should be set to 1.5 bar when cold) Make sure that all hot water tap outlets & showers are purged and free from air.
- b) Check that external controls are not calling for heat at this stage.
- c) Check that the Main RCD within the boiler is in the ON position. Now turn on the main power supply to the boiler.
- d) Adjust the P2 Dial (CH) from the OFF position to your desired system temperature, (Generally 65-70 deg C) The temperature will be shown on the LCD screen when you make the adjustments.
- e) Adjust the P1 Dial (DHW) to your desired temperature, the temperature will be shown on the LCD screen.
- f) Now set your external controls to call for heat. The boiler will automatically fire and start heating the system. after a few minutes open the Hot tap/shower outlet and purge them free of air.

Note:

- The system pressure will need topped up during the commissioning process due to system air being emitted from the automatic air vent within the boiler.
- Set the boilers DHW flow rate to the recommended settings by adjusting the incoming main water stop cock supplying the boiler. Recommended flow rates are shown on page 27.

5. USER INSTRUCTIONS

5.1 CONTROL PANEL

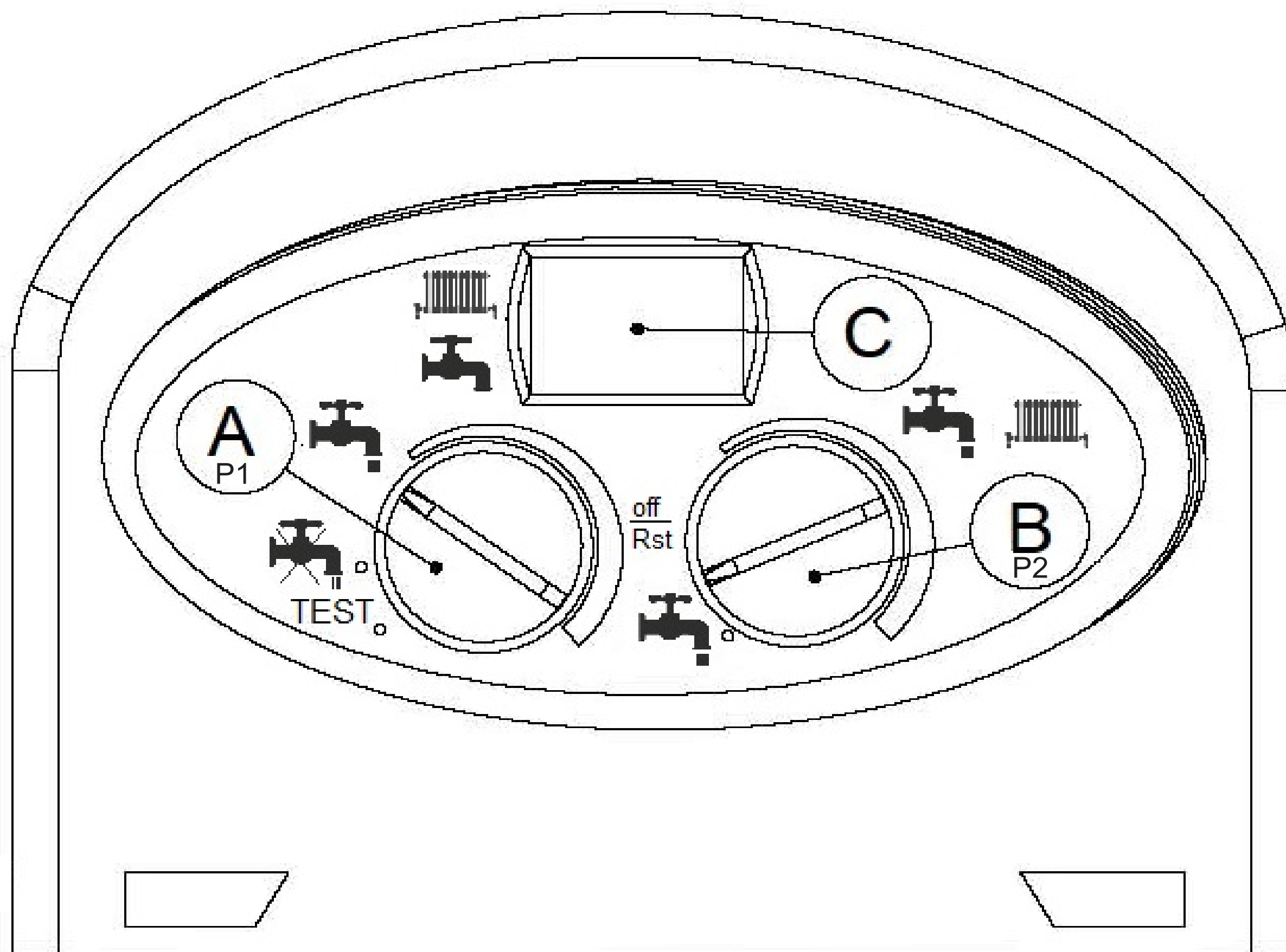

All boiler functions are adjusted from the front control panel.

A. P1 KEY



Select this icon when there is a requirement for instant hot water. Turning the A-P1 dial clockwise will adjust the HW temperature. Once you have selected your required temperature, the LCD screen (C) will automatically revert back to the actual water temperature being provided at that time.



Select this icon to turn instant HW OFF. In this position the instantaneous hot water function will be disabled.

TEST : This mode is for SERVICE ENGINEER TESTING ONLY and should not be used by the end user.

B. P2 KEY

OFF / RESET : In this position the boiler is switched OFF. This setting is also used to reset the boiler if an Error code is shown.

Note: If left in this position, Frost, Pump & Diverter protection will be Disabled!

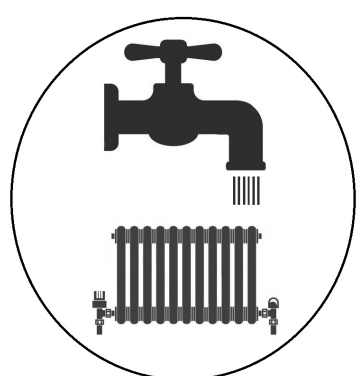

Winter Mode : In this mode both DHW and CH is activated and ready for a call for heat from an external Thermostat or HW outlet. Turning the B-P2 dial clockwise will allow you adjust the CH temperature. Once you have selected your required temperature, the LCD screen (C) will automatically revert back to the actual system temperature being provided at that time.



Summer Mode : DHW only. When the B-P2 dial is set to this position the CH will be disabled. You can adjust the desired DHW temperature by turning the B-P1 key.

C. DIGITAL SCREEN

Operating parameters and errors codes.

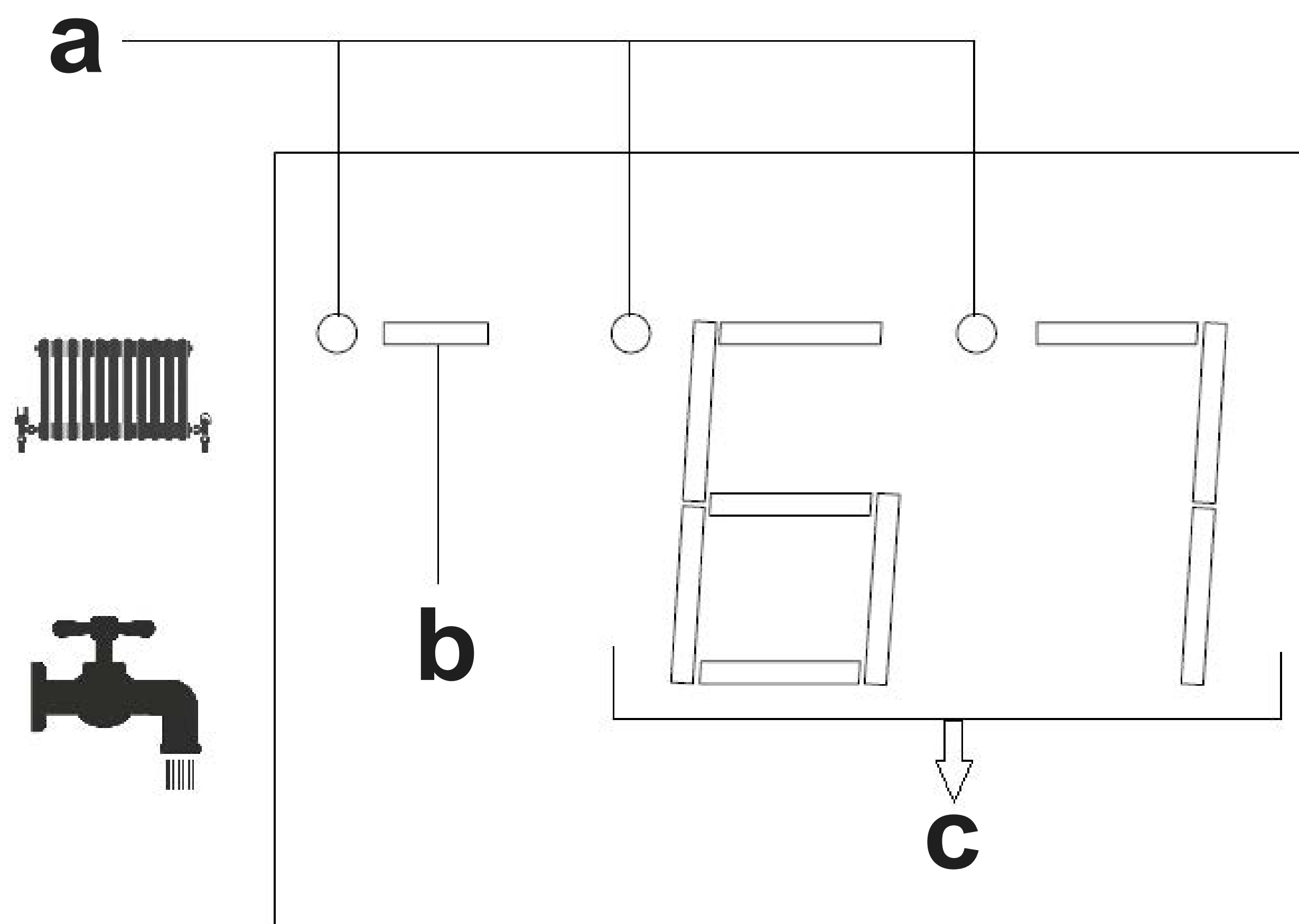

- a) Heating Capacity Indicators: Shows which heating elements are in operation, indicating the modulation level of the boiler.
- b) Heating Mode Indicator: The dash position on the display shows whether the boiler is operating in CH or DHW mode.
- c) Digital Units: Adjusted temperature, current boiler temperature and error codes are shown in this section of the display.

5.2 ERROR CODES

CODE ON DISPLAY

EXPLANATION

H 1	Central Heating Sensor Error
H 2	DHW Sensor Error
H 3	Central Heating Circuit Low Water Pressure Error
H 4	High Temperature Measurement Error 95°C
H 5	Limit Thermostat Error
H 6	Main Heat Exchanger Water Level Error

5.3 TROUBLESHOOTING

ERROR CODES			
Error Code	Explanation	Reason	Solution
H1	Central Heating Sensor Error	a) Disconnected Sensor Cable b) Failure in NTC Sensor c) Mainboard Failure	a) Check the cable and socket b) Replace the NTC Sensor c) Replace the mainboard
H2	DHW Sensor Error	a) Disconnected Sensor Cable b) Failure in NTC Sensor c) Mainboard Failure	a) Check the cable and socket b) Replace the NTC Sensor c) Replace the mainboard
H3	Central Heating Circuit Low Water Pressure Error	a) Air Trapped in the System b) Water leakage on the boiler or installation c) Expansion tank failure	a) Vent the air from the boiler and radiators. Afterwards fill the system up to 1.5 bar b) Check all piping and connections for leakage. c) Check the counter pressure of the expansion tank. Pressurize the tank up to 1.1 bar with nitrogen. If the membrane is damaged replace the expansion tank.
H4	High Temperature Measurement Error > = 95°C	a) Air trapped in the system b) Valves on the installation may be closed c) Particulate filters may be clogged d) Circulation pump failure e) Mainboard Failure	a) Vent the air from the boiler and radiators. Afterwards fill the system up to 1.5 Bar b) Check that all the valves are open c) Clean the filters d) Check the pump and turn the rotor manually to overcome jamming. Replace the pump if necessary e) Replace the mainboard
H5	Limit Thermostat Error	a) Air trapped in the system b) Valves on the installation may be closed c) Particulate filters may be clogged d) Circulation pump failure e) Mainboard Failure f) Limit thermostat failure	a) Vent the air from the boiler and radiators. Afterwards fill the system up to 1.5 Bar b) Check that all the valves are open c) Clean the filters d) Check the pump and turn the rotor manually to overcome jamming. Replace the pump if necessary e) Replace the mainboard f) Check the electric connection of the thermostat. Replace the thermostat if necessary.
H6	Main Heat Exchanger Water Level Error	a) Air trapped in main heat exchanger b) Float level sensor failure	a) Vent the air inside the main heat exchanger using the manual air vent. Fill the system up to 1.5 bar. b) Check the cable connection of the float sensor. c) Check that the float is not stuck. Clean the float level sensor so that the float moves freely. Replace the float sensor if necessary.

6. SAFETY SYSTEM

EHC Fusion Astro Electric Combi Boilers have the following safety features to ensure the highest level of safety is achieved.

6.1 INTERNAL RCD DEVICE (SHORT CIRCUIT RELAY)

In case of short circuit, the relay shuts off the electrical power supply to the boiler preventing any possibility of electrocution.

6.2 HEAT EXCHANGER FLOAT LEVEL SENSOR (H6)

The Float sensor prevents the boiler from running when the water level within the heat exchanger is low. The boiler will show an H06 Error code. This feature helps prevent damage to the elements within the boiler. The air within the heat exchanger must be completely removed by opening the manual air valve which is located at the top of the heat exchanger. If the water pressure drops during this process, the display will show an H03 error code.

6.3 LOW WATER PRESSURE

If the pressure at the heating circuit is below 0.7 bar, the boiler will not operate and the H3 warning code will appear on the digital display. This can be rectified by filling the system via the filling loop to the recommended 1.5bar when cold. (The filling loop must be disconnected after use)

6.4 OVERHEAT LIMIT THERMOSTAT

If the water temperature within the heat exchanger ever exceeded 93°C, the boiler's main control PCB will disable the supply to the heat exchanger and an H5 error code will be shown. When the water temperature of the heat exchanger drops to 60°C, the boiler will automatically start working again. If this failure occurs more than twice then a service engineer should be called to investigate the fault.

6.5 SHORT CIRCUIT THERMOSTAT

This is a secondary overheat safety device. If the overheat thermostat does not function and the boiler temperature reaches 96°C, the short circuit thermostat will conduct a neutral supply to the boiler chassis that will cause the boiler's RCD to trip, disabling the main power supply to the boiler. .

6.6 FROST PROTECTION

If the temperature within the heating system drops below 5°C, there is security system will automatically activate the boiler. When the water temperature within the heat exchanger reaches 40°C the activation is stopped. In order for this system work the heating and hot water selector switches must be set to the minimum setting.

6.7 DOMESTIC HOT WATER NTC SENSOR

When a sensor failure occurs in hot water system, H2 warning code appears on LCD screen.

6.8 CENTRAL HEATING NTC SENSOR

When a sensor failure occurs in central heating system.H1 warning code appears on the LCD screen

6.9 HIGH WATER PRESSURE PROTECTION

When the system is over pressured, the 3 bar safety valve discharges water. (System pressure should be set to 1.5 bar cold)

6.10 PRECAUTION AGAINST PUMP LOCK

When the boiler is in the OFF position, the pump will operate every 24 hours by the control PCB for a short period of time to prevent the pump from sticking.

6.11 3-WAY VALVE ACTUATOR MOTOR SAFETY

When the boiler is in the OFF position, the 3-way valve is operated in every 24 hours by the control PCB for a short period of time. The valve will return to its previous position after time.

6.12 AUTOMATIC BY-PASS

If there are thermostatic valves fitted on the system and the minimum flow rates cannot be achieved the boilers internal by-pass will activate to provide the required minimum flow rate to prevent the boiler over heating.



CAUTION!

- The stand-by safety system features, such as frost protection, pump lock protection and 3-way valve actuator safety are only active if the electrical supply is ON.
- During Winter if the property is subject to temperatures below 0°C and the system is not used for long periods of time it is recommended that the boiler and heating system is drained down to prevent frost damage.

7. TECHNICAL TABLE

Capacity					
Heating Power	kW	12	15	18	24
Output	BTU	40945	51182	61418	81891
Maximum Working Pressure (Heating)	Bar	3	3	3	3
Internal Expansion Vessel	Ltr	8	8	8	8
Maximum Working Pressure (DHW)	Bar	6	6	6	6
Heating Circuit Temperature Range	°C	30-80	30-80	30-80	30-80
Hot Water Temperature Range	°C	30-60	30-60	30-60	30-60
Hot Water Output ($\Delta T = 30^{\circ}\text{C}$)	L/min	5	6	9	11
Dimensions					
Height	mm	740	740	740	740
Width	mm	435	435	435	435
Depth	mm	320	320	320	320
Net Weight	Kg	38	38	38	38
Gross Weight	Kg	42	42	42	42
Electrical					
Supply Type		1Ph	1Ph	3Ph	3Ph
Minimum Cable Size	mm ²	16	16	5x6	5x6
Time Delayed RCD Specification	A/mA	63/30	80/30	40/30	40/30
Circuit Protective Device	Amps	63	80	32	40
Voltage/Frequency	V~Hz	230/50	230/50	400/50	400/50
Load Current	Amps	52	65	26	35
Element Resistance	ohms	13	33	27	20
Hydraulic					
Heating Circuit Pipe Connections	inch	3/4"	3/4"	3/4"	3/4"
DHW Pipe Connections	inch	1/2"	1/2"	1/2"	1/2"

8. MAINTENANCE

We recommend the following actions during the service of this appliance.

- 1- Check for internal & external leaks and repair as necessary
- 2- Check the status of the device visually
- 3- Check the safety devices of the boiler (Limit, Over Heat & RCD Limit)
- 4- Check all electrical connections are tight and set to the correct torque settings (2.8 - 3.5 Nm)
- 5- Check the operation of resistances with required measurement equipment.
- 6- Check the hot water temperature and flow rates
- 7- Check the general operation of the device
- 8- Clean all dust from Fan & PCB
- 9- Check Expansion vessel pressure is set to 1.2 bar when cold.
- 10- Clean External magnetic filter
- 11- Check system pressure is set to 1.5 bar when cold

9. GUARANTEE CONDITIONS

The boiler comes with a standard 24 months warranty. Warranty registrations must be completed and returned to EHC. If boilers are not registered the warranty on the boiler will start from the date of purchase.

Boilers must be installed by a fully qualified engineer and commissioned as per the instructions within this manual. The Manufacturer cannot be held liable for any adverse installations that do not meet current regulations. The guarantee of the boiler will be invalidated under these circumstances:

- 1- Improper installation, improper electricity connection.
- 2- Damages arising from places with humidity or water contact.
- 3- The assembling of non authentic and non approved parts to the boiler.
- 4- Extreme high or low temperature of the environment the boiler is installed in..
- 5- Damages that occur as a result of inappropriate stock holding.
- 6- Damages that are results of damaged parts during transit.
- 7- Damages caused by limescale. (Max 200 PPM 200)
- 8- Damages as a result of poor installation and maintenance that do not meet current standards or directives.
- 9- Use of the boiler for purposes other than what the device is designed for.
- 10-Boilers with serial number modification.
- 11-Boilers that experience frost damage.
- 12-Damages to electronics caused by power surges or spikes.
- 13-Damages caused by system contamination.

10. EXPLODED VIEW

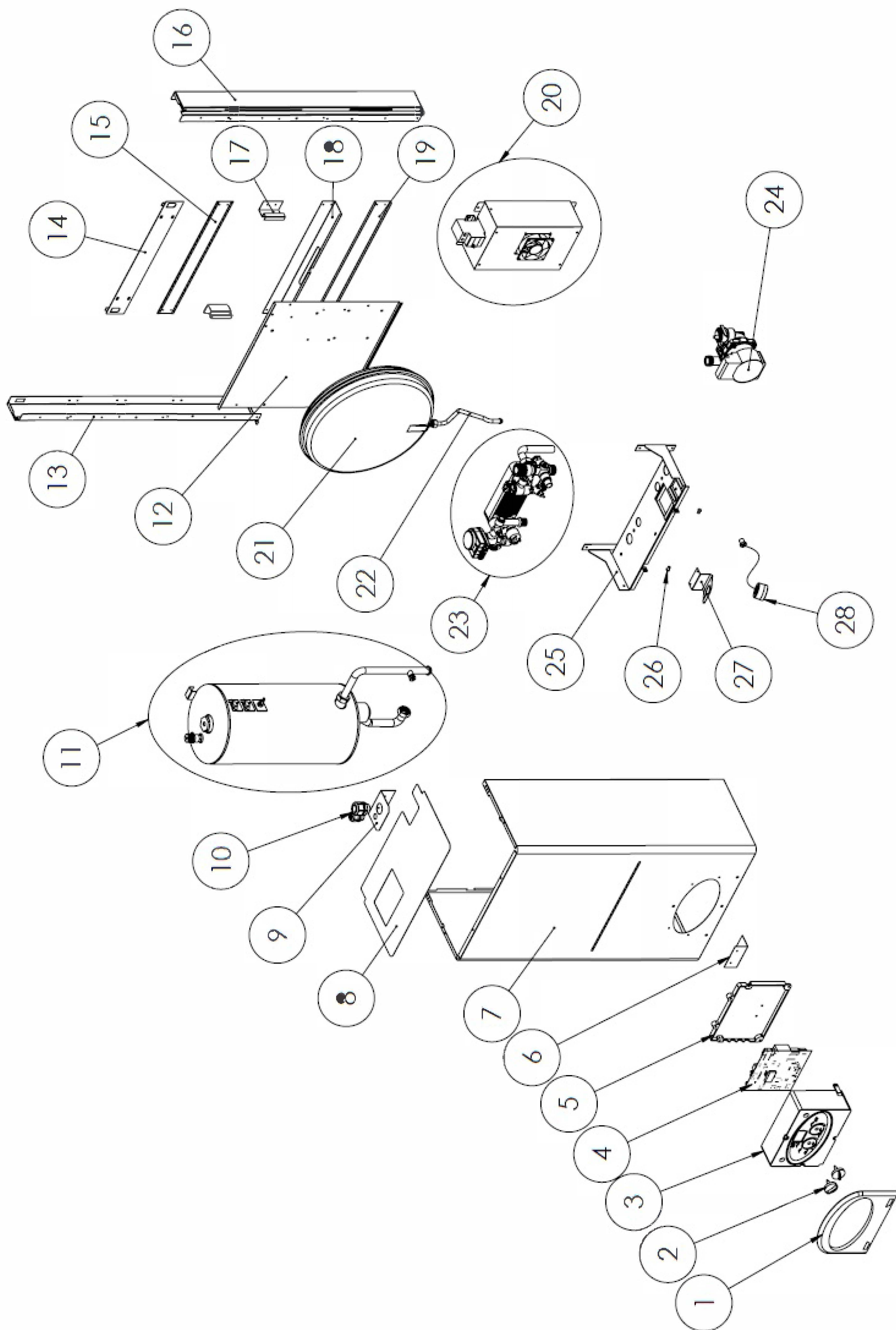

10.1 MAIN HEAT EXCHANGER GROUP DETAIL

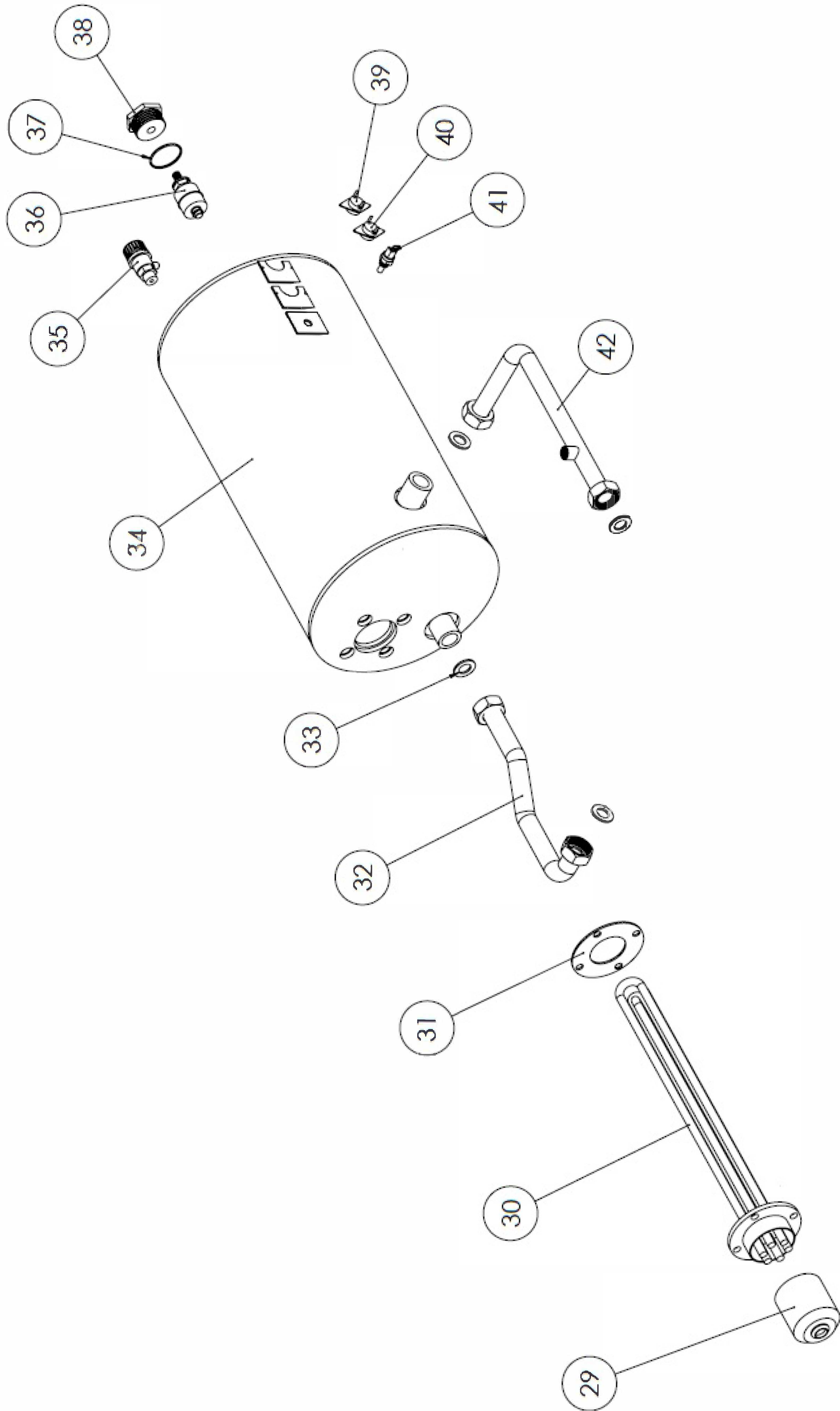

10.2 HYDROLIC GROUP DETAIL

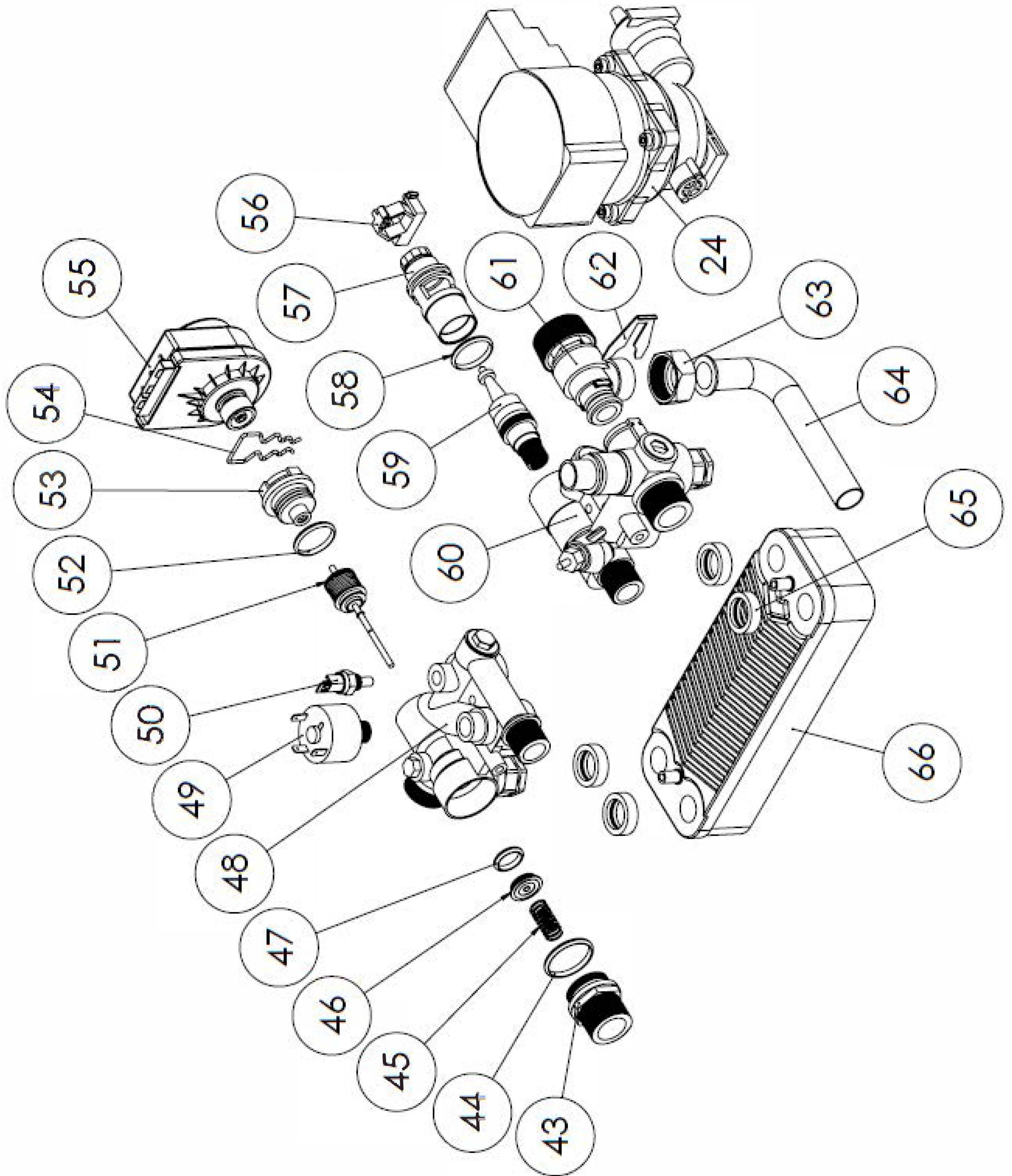

10.3 RELAY BOARD GROUP DETAIL

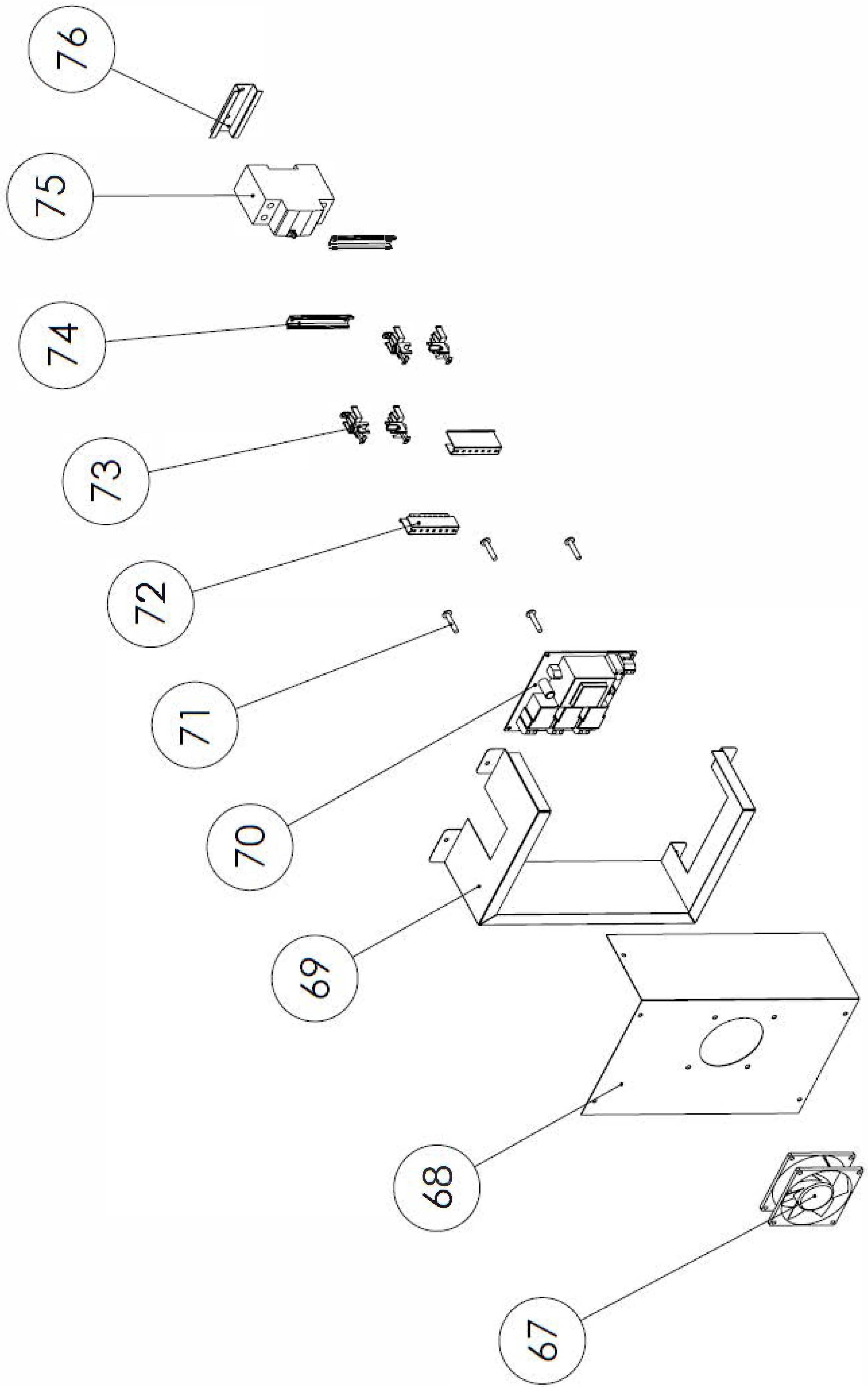

10.4 EXPLODED VIEW PARTS LIST

1. Plastic frame
2. Control buttons
3. Control panel
4. Mainboard
5. Control panel rear cover
6. Panel fixing plate
7. Front boiler cover
8. Top boiler cover
9. RCD protective cover
10. Cable glands
11. Main heat exchanger group
12. Boiler main chassis
13. Left chassis
14. Wall mounting plate
15. Upper support plate
16. Right chassis
17. Expansion vessel fixers
18. Expansion vessel support plate
19. Lower support plate
20. Relay board group
21. Expansion vessel
22. Expansion vessel copper pipe
23. Hydrolic group
24. Circulation pump
25. Hydrolic group mounting plate
26. Control panel fixers
27. Pressure gauge steel frame
28. Pressure gauge
29. Insulator caps
30. Heating elements
31. Heating element gasket
32. Copper flow pipe
33. 3/4" gasket
34. Main heat exchanger
35. Manual air vent
36. Float level sensor
37. Float sensor o-ring
38. Float sensor connector
39. Limit thermostat
40. Short-circuit thermostat
41. CH temperature NTC sensor
42. Copper return pipe
43. R 3/4" flow outlet
44. Flow manifold outlet o-ring
45. Flow manifold pressure spring
46. Pressure spring retainer
47. Pressure spring retainer o-ring
48. Flow manifold
49. Water pressure switch
50. DHW temperature NTC sensor
51. 3-way valve spring rod
52. 3-way valve seat o-ring
53. 3-way valve seat
54. 3-way valve clips
55. 3-way valve actuator motor
56. Electronic flow sensor
57. Flow sensor housing
58. Flow sensor o-ring
59. Flow sensor interior set
60. Return manifold
61. 3bar safety valve
62. Safety valve clips
63. 1/2" fitting
64. Safety valve outlet copper pipe
65. Plate heat exchanger o-ring
66. Plate heat exchanger
67. Cooling fan for relay board
68. Relay board top cover
69. Relay board side cover
70. Relay board
71. Plastic spacers
72. Electric terminals
73. Terminal fixers
74. Terminal rails
75. Monophase RCD device
76. RCD fixing rail



(Waste Electrical & Electronic Equipment)

(Applicable in the European Union and other European countries with separate collection systems).

This marking shown on the product or its literature, indicates that it should not be disposed of with other household wastes at the end of its working life.

To prevent possible harm to the environment or human health from uncontrolled waste disposal, please separate this from other types of wastes and recycle it responsibly to promote the sustainable reuse of material resources. Household users should contact either the retailer where they purchased this product, or their local government office, for details of where and how they can take this item for environmentally safe recycling.

Business users should contact their supplier and check the terms and conditions of the purchase contract. This product should not be mixed with other commercial wastes for disposal.

