

The FUSION Range of Boilers

INSTALLATION & TECHNICAL MANUAL



Fusion



ehc

the electric heating company

If you require any further assistance:

Telephone: 01698 820533

Fax: 01698 825697

E-mail: info@electric-heatingcompany.co.uk

Or visit our website

www.electric-heatingcompany.co.uk



Page Contents

INTRODUCTION	2
PREPARATION	3
INSTALLATION	4
ELECTRICAL CONNECTIONS AND CONTROLS	8
EXTERNAL CONTROL WIRING	9
INTERNAL BOILER WIRING	10
EXTERNAL BOILER WIRING	13
BOILER DIMENSIONS	13
USER INSTRUCTIONS	14
FAULT FINDING	18
TECHNICAL SPECIFICATIONS	19

This appliance is not intended for use by persons (including children) with reduced physical, sensory or mental capabilities, or lack of experience and knowledge, unless they have been given supervision or instruction concerning use of the appliance by a person responsible for their safety.

Children should be supervised to ensure that they do not play with the appliance.

INTRODUCTION

Please read and follow the installation and operating instructions carefully, to ensure the long life and reliable operation of this appliance.

The Electric Heating Company may make minor changes if necessary in the appliance that will not be shown in the operating instructions, so long as the main features of the boiler remain the same.

All boilers come with a 24 month warranty that covers all defects originating from faulty materials and workmanship in the manufacture of the boilers.

The warranty covers the replacement of any faulty parts and labour costs.

The warranty will not cover any damage to the boiler from poor or incorrect installation work.

The warranty will not cover any call out charges that are a user or external control fault.

The warranty will not cover water leaks into the boiler. All plumbing joints must be checked.

The warranty card should be completed and sent back to The Electric Heating Company as soon as possible for registration.

A magnetic filter must be fitted to the system in the horizontal position and cleaned every 12 months.

PREPARATION

Instructions and Building Regulations

This appliance must be fitted in accordance with the following instructions.

The Local Building Regulations

The Building Regulations

The Building Standards, (Scotland-consolidated) Regulations.

Local water bylaws. British Standards- code of practice

BS EN 12828

Heating systems in buildings. Design for water-based heating systems.

BS EN 12831

Heating systems in buildings. Method for calculation of the design heat load

BS EN 14336

Heating systems in buildings. Installation and commissioning of water based heating systems

BS7671

Requirements for electrical installations. IEE Wiring Regulations. Seventeenth edition.

BS EN 13831

Closed expansion vessels with built-in diaphragm for installation in water

C.O.S.H.H.

Materials used in the manufacture of this appliance are non-hazardous and no special precautions are required when fitting or servicing this appliance.

PREPARATION

1. Load Check

A load check should be taken into consideration when installing high output boilers.

2. Boiler location

The boiler must be fitted on a wall that will provide an adequate fixing, and should be fitted in a location that the boiler and pipe work are not subject to frost and damp conditions.

3. Central heating

Detailed recommendations are given in BS 5449, BS 6700 and CP 342, Part 2.

Pipes forming part of the useful heating surface should be insulated to prevent any potential heat loss or frost damage. (BS 6700).

Drain valves should be fitted at the lowest point of the system pipe-work in an accessible position.

Drain valves should be in accordance with BS 2879 and copper tube to BS 2871. Part 1 is recommended.

LOCATION

The boiler can be installed in almost any location within a domestic or commercial property, however consideration should be given to future maintenance. Never leave the boiler switched off if there is danger of having temperatures below 0°C in the room where it is located.

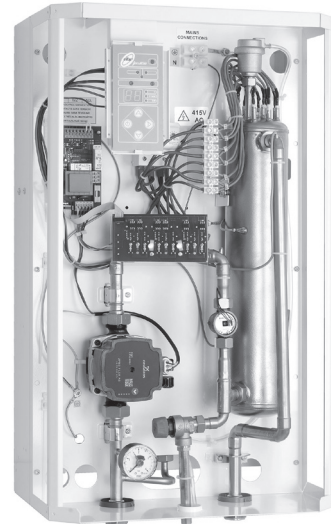

Fusion boiler

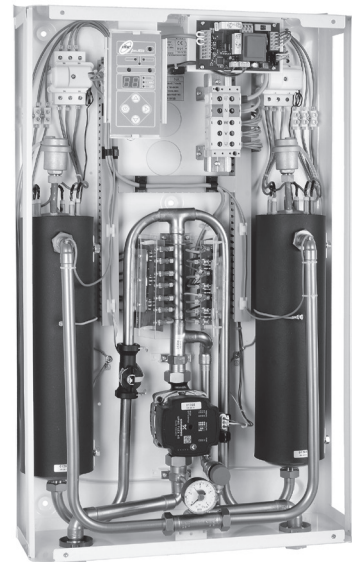

48 Fusion boiler

MOUNTING THE BOILER

Mount the boiler onto a flat wall surface that will be capable of taking the boilers full weight. Use the mounting template provided with the boiler, mark and drill the fixing holes taking into consideration you leave the minimum clearances required around the fusion boilers.

We recommend that a minimum clearance of 450 mm should be allocated for the removal of the front cover and adequate access to the boiler plumbing and the internal electrical connections. A 50 mm allowance should be made at either side of the boiler to allow free flow air into the boiler case and allow access to screws on the boiler case (150 mm for Slimline model).

THE BOILER MUST BE INSTALLED IN THE UPRIGHT POSITION, FAILURE TO DO SO WILL INVALIDATE THE WARRANTY.

INSTALLATION

The boiler must be installed by a professional plumber or heating engineer and must be connected to the power supply by a qualified electrician.

The Electric Heating Company Ltd will not be held responsible for faulty installations which are performed by unqualified tradespersons.

1. Pipe Connections

All Fusion Electric Boilers have a 22 mm compression connection at the boiler's flow and return pipes however the 48kw version has 28mm compression connections. Please note that the boilers are supplied with blank washers fitted for transit purposes. These must be removed and replaced with the washers supplied. The 2 spare pcb fuses supplied must be left inside the boiler.

The flow (red) and return (blue) are clearly marked on the external case and under no circumstances should these connections be reversed.

Hot connections are not recommended at the boiler for future maintenance and boiler disconnection. Lockshield valves are recommended

2. Case Removal

Remove outer screws from boiler case and push upwards and outwards taking care to remove internal earth connections. (Slimline model: remove screws on the right hand side and swing the boiler case open). Earth connections must be re-connected before the case is reinstated.

3. Isolation valves

Consideration should be made for the provision of lockshield isolation valves on the flow and return pipe-work. Such valves must be full bore and not ball valves.

We recommend isolation valves on each side of the magnetic filter.

The insertion of ball valves will reduce the recommended flow through the boiler and promote premature boiler shut down caused by poor flow rate.

4. Auto air vents

An Auto air vent is integral within the boiler however an additional auto air vent must be fitted at the cylinder coil if the boiler is being used for central heating and domestic hot water.

5. Boiler Sizing

Calculate the space heating requirements in accordance with BS 5449. If the boiler is to heat the domestic hot water, an allowance of 3kw (10,239 Btu's) should be made.

6. Insulation

Where practical and if at all possible, we recommend that all pipe-work be insulated, in particular the primary pipe-work within the boiler cupboard. This is to reduce heat loss and reduce high cupboard temperatures from exposed pipe-work. (BS 6700).

7. System Design

As the boilers are of a low water content an open circuit must be achieved incorporating 2 metres of continuous 22 mm pipe-work after boiler connections and before any zone valves.

We recommend the use of an automatic bypass within this circuit and set to the relevant settings to allow the minimum flow rates to pass through the boiler (8 l per min) when all radiator thermostats close.

Allowance should be made for a minimum size radiator of 600mm x 600mm single convector or equal to 2500 Btu to be installed within the heating circuit and locked open. This will be located in the room that has the room stat installed.

To comply with building regulations, Part L and Part J (in Scotland) room and cylinder stats must be fitted.

8. Water connections

Provisions must be made for the replacement of water lost from the heating system (sealed systems). Reference should be made to BS 6798, for the methods of filling and make up of water.

There must be no direct connection between the boilers central heating system and the main water supply. When mains water is required to fill the system directly, all Local water bylaws must be observed. Any connection made must be disconnected after use.

9. Flushing

The system **must be flushed** to within 10% of mains water PPM to ensure that no debris is trapped in the system as this may result in boiler failure. Where existing radiators and pipe-work are utilized a power flush must be carried out to remove debris. For further guidance please see section - Flushing & System Protection.

10. System pressures

All boilers are tested to 4.0 bar. The normal working pressure of the boilers should be set to 1.5 bar. All sealed systems should comply with the relevant building regulations and standards and to BS 4814, (Specification for Expansion Vessels).

Please Note

In order to protect the Flow Sensor located within the boiler, it is imperative that you install a mechanical-magnetic filter on the return inlet to the boiler. This will enable you to clean the filter at regular intervals and will also ensure that the boiler does not become contaminated by system residue.

11. System types

The 6, 9, 12, 14.4, 36 & 48kW boilers can be used in various system designs. Please refer to The Electric Heating Company for more details on our Fusion Boiler for under floor heating. We are able to supply a heat pack that contains the relevant control valves, cylinder and room thermostats required to configure an S plan heating system. The heat pack has all the necessary components that you need to connect the systems controls and plumbing configurations for S Plan design.

We also recommend the use of thermostatic radiator valves on all radiators except in the room that has the wall thermostat fitted. If a bypass radiator has been used in the system, it should be fitted with lock shield valves and left in the fully open position.

If a bypass radiator has not been used then a system bypass of 2 metres of 22 mm copper pipe incorporating an automatic bypass valve must be used and can be set to 8l/min from the front control panel.

Systems should be designed to current building regulations.

12. Expansion vessels

All boilers up to 36kW have an internal 6L expansion vessel, where the system volume is greater than 50L an additional external expansion vessel of suitable size will be required. The 48kW fusion does not come with an integral expansion vessel therefore it is the installers responsibility to correctly size and install an expansion vessel within the system.

Water Loss

If water loss occurs due to natural evaporation, leakage or any other breakdown in water seals, the boiler will not operate.

The boilers flow sensor needs a minimum of 5 litres per minute to operate. If this cannot be achieved the boiler will shut down.

We recommend a minimum flow setting of 8l/min.

Investigation

Should BOIL OVER/BOIL DRY/WATER LOSS occur, investigation as to why the system has failed MUST take place. Power should only be reinstated after the fault has been rectified.

The main overheat stat on the boiler can be re-set, this is positioned at the top of the boiler market WT3. To re-set, push the brass pin with a small screwdriver. The pin will click into place when re-set.

ENSURE THAT THE MAINS POWER SUPPLY TO THE BOILER IS SWITCHED OFF PRIOR TO RE-SETTING.

13. Commissioning

IMPORTANT:

TURN ON THE ELECTRICAL POWER SUPPLY TO THE BOILER. MAKE SURE THAT THE PROGRAMMER IS NOT CALLING FOR HEAT AT THIS STAGE!

FILLING THE HOT WATER CIRCUIT. (If Applicable)

1. Check the pressure in the potable vessel is set to 3 Bar
 2. Check that all plumbing connections are tight
 3. Open the furthest away tap outlet
- Note: Make sure that the filling loop is closed at this stage!**
5. Turn on the mains water supply to the unit
 6. It will take a few minutes to fill the cylinder, once the water comes through the tap outlet let it run
 7. Open the other hot water outlets and purge all air out of the system
 8. Once fully purged close all the outlets and further check for leaks

FILLING THE PRIMARY HEATING CIRCUIT.

THE PRIMARY CIRCUIT MUST BE FLUSHED IN ACCORDANCE TO BS 7593

1. Connect the primary filling loop and tighten
2. Make sure that all primary connections are tight before filling
3. Open the filling loop and allow the system to start filling
4. Press the right arrow key on the boiler control panel until the A (bar) led is illuminated
5. Fill the system to 2 bar, then start to purge the radiators until all the air is out the system.
6. This will have to be repeated several times to fully purge the system re-filling as you go.

System protection:

Failure to protect the system will invalidate the manufacturer's warranty.

1. Fill the system with cold mains water to the recommended pressure 1.5 bar and check for leaks, then drain the system thoroughly making sure all drain cocks are fully open and that the system is completely drained.
2. Add Fernox F3 cleaner to the system at the furthest point from the boiler, this is to allow the substance to fully dilute throughout the system. If you are unsure of the correct dose rate, contact Fernox on 03301007750 for advice.
3. Re-fill the system and circulate the F3 cleaner prior to the boiler being fired up. Commission the system in the normal way. The cleansing agent must be in the system for a minimum 1 hour with the system running at normal operating temperature. A longer period of time would be more beneficial to the cleansing process especially if excess flux was used or is an old system. F3 cleaner can be left in the system for up to a maximum of one week running on a normal heating cycle. (We recommend that existing systems are power flushed as per BS 7593 and PAS33 regulations)
4. Drain and flush the system thoroughly to remove the cleaning agent and any debris or contaminants. This is a critical part of the cleaning process and must be carried out correctly. Use a rinse test meter (TDS), such as the Fernox CTM. The reading must be within 10% of the mains ppm value.
5. After the system has been thoroughly flushed and TDS readings are within 10% you can now add Fernox F1. This will protect against the formation of scale, corrosion and microbiological growths. It is crucial however, that for the protector to work correctly, the system must be properly cleansed and flushed.
6. Now attach the label included within the Fernox F1 packaging completed and attached adjacent to the boiler. We recommend inhibitor levels are checked on an annual basis (usually during the service) or sooner if the system content is lost.
This should be carried out using a Fernox inhibitor Test Kit. Fernox Technical Service Helpline on 0870 870 0362 for

14. Start-up / commissioning

1. Ensure the system is filled with water and correctly vented.
2. Check if the appropriate system installation pressure is reached (see the "TECHNICAL DATA" section) by referring to the pressure gauge at the bottom left of the boiler.
3. Set the external controls to call for heat.
4. Switch the boiler on by pressing the power button.
5. Check the pump is set to the correct mode (see table 15.1). To do this, press the pump arrow button for no more than 2 seconds. The LED's should signal an operating mode at the place pointed by arrow.
6. If the LEDs are signalling a different operating mode than recommended in table 15.1, set the appropriate mode according to the following instructions: press the pump arrow button for longer than 2 seconds, but less than 10 seconds (LED's will start to flash), the pump then switches to the programming mode. LEDs glow to indicate the current settings. To change the settings of the pump in accordance with table 15.1, you can set the right combination of glowing LEDs by pressing the pump arrow button. Once the LED combination is set correct, by not pressing the button for 10 seconds the pump will remember this setting and will exit from the programming mode back to performance view.

Note: holding the pump arrow button for more than 10 seconds will enter the pump into key lock mode. This prevents the user from altering the pump settings. To remove the key lock and allow the pump settings to be changed, hold the pump arrow button again for more than 10 seconds.

7. Ensure adequate flow through the boiler is reached (the 'H' indicator is on with a constant light). The pump should self vent after a short period of running. If necessary assist the venting process in the following way; Warning the screw head in the centre of the pump is not intended to be used to assist venting of the pump, Damage to the pump internals may occur!
 - close the isolation valve on the outlet,
 - leave boiler running for 15 sec.
 - open the isolation valve.
8. Set the external controls to the required program and the boiler to the required system temperature, see the "Operating" section.

In the case of a seized pump impeller due to a long layover out of the heating season and simultaneous non-compliance with the recommendation to cycle the pump every couple of days, please restore proper movement of the impeller. To do this, please use PH2 screwdriver, press and turn the screw anti-clockwise, located in the middle of the front panel of the pump (Figure 3) until the pump impeller is spinning freely.

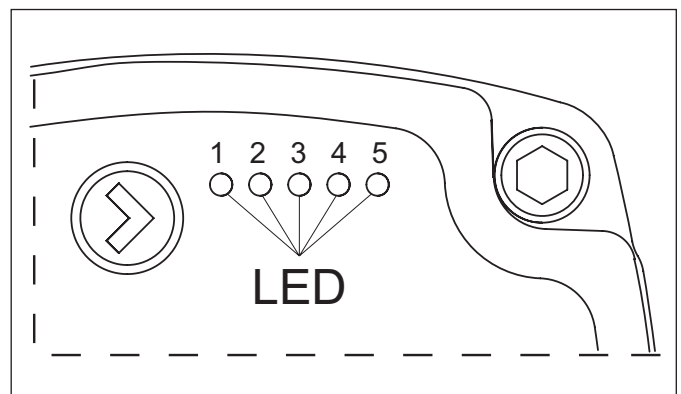
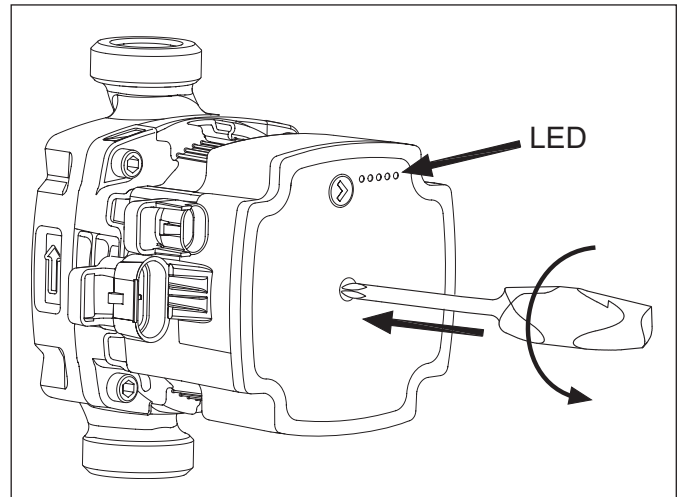

Table 15.1

Rated power [kW]	Pump lifting height [m]	LED 1 red	LED 2 yellow	LED 3 yellow	LED 4 yellow	LED 5 yellow
4	4	•	•			
6-9	5	•	•		•	
9-1-14	6	•	•		•	•
14 - 36	7	•	•			•

Alarm status

If the pump has detected one or more alarms, the bicolored LED 1 switches from green to red. When an alarm is active, the LEDs indicate the alarm type as defined in the table below. If multiple alarms are active at the same time, the LEDs only show the error with the highest priority. The priority is defined by the sequence of the table. When there is no active alarm anymore, the user interface switches back to operation mode.

Table 15.2

Display	Indication	Pump operation	Counter action
One red LED + one yellow LED (LED 5)	Rotor is blocked.	Trying to start again every 1,5 seconds	Wait or deblock the shaft.
One red LED + one yellow LED (LED 4)	Supply voltage too low	Only warning pump runs	Control the supply voltage
One red LED + one yellow LED (LED 3)	Electrical error	Pump is stopped because of low supply voltage or serious failure	Control the supply voltage / Exchange the pump

CENTRAL HEATING ONLY

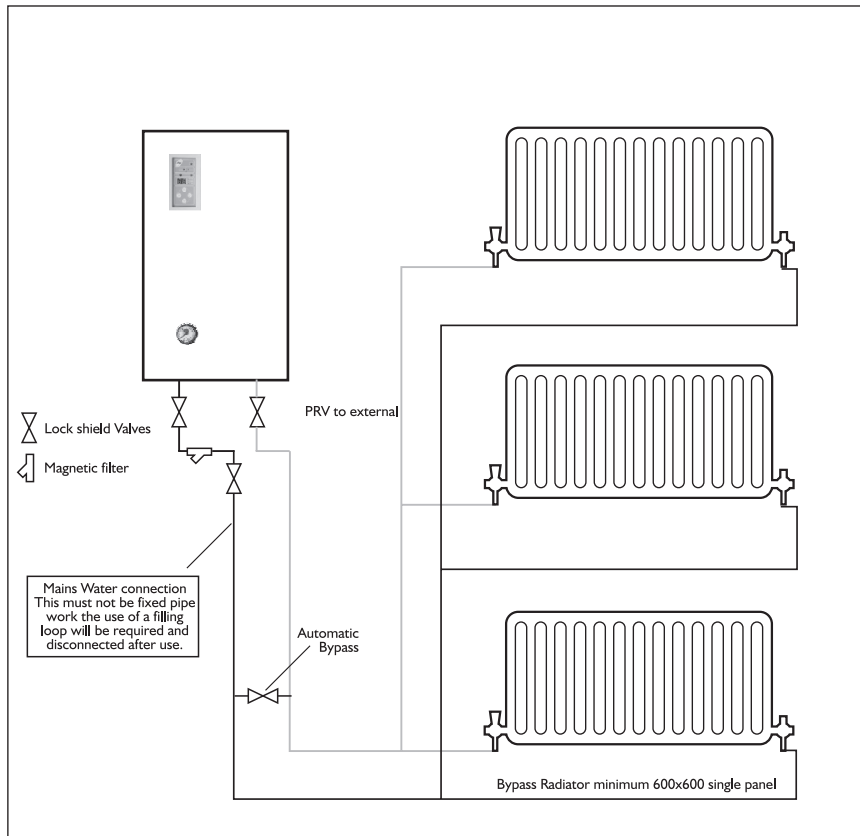

CENTRAL HEATING & DOMESTIC HOT WATER

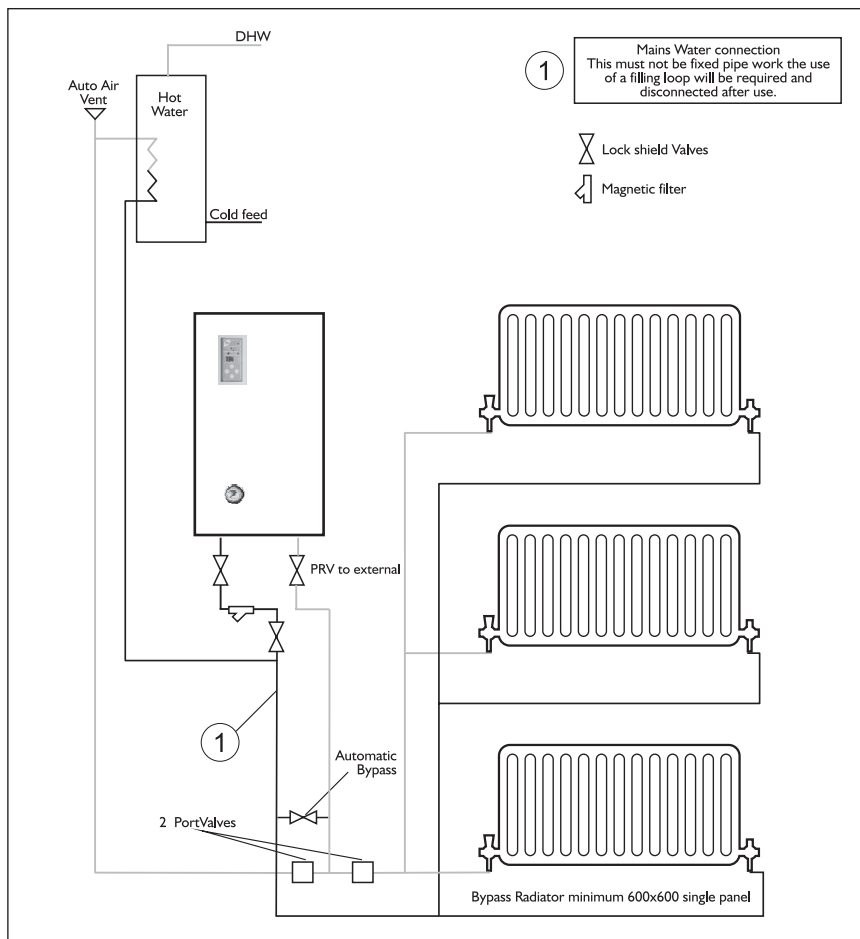

ELECTRICAL CONNECTIONS AND CONTROLS

ALL WIRING MUST BE CARRIED OUT IN ACCORDANCE WITH CURRENT IEE REGULATIONS. BS 7671

ALL ELECTRICAL CONNECTIONS MUST BE MADE BY A QUALIFIED ELECTRICIAN.

Load check must be taken into consideration when installing high power boilers. This will be carried out by a qualified electrician. There may be an additional requirement to upgrade the incoming main fuse supplying the property if other high power devices are used within the property. E.g Electric Showers. If an electric shower is present we recommend that a Shower Sensor is installed within the system. This will cause an interrupt to the boilers control signal when the shower is in use. It will disable the boiler protecting the electrical system from overload.

All boilers must be protected at the meter position with a 30mA double pole RCD with a minimum of 3mm contact separation accompanied by a suitably rated MCB. If the boiler is not fitted local to the meter position then an additional isolation switch must be fitted local to the boiler for each supply. If the property is prone to lightning strikes or power cuts it is recommended to install a suitable surge protection device to the boiler supply. This will reduce the risk of damage to the boiler electronics during these events.

THIS APPLIANCE MUST BE EARTHED.

All pipe work must be earthed in accordance with the current IEE Regulations – BS 7671

After completion of all electrical works, an electrical safety check should be carried out i.e. short circuit, earth continuity, resistance to earth and polarity check, and all relevant Test Certificates completed and issued to the customer.

Never open the front cover until all power supplies to the boiler have been disconnected.

ELECTRICAL CONNECTIONS

The boiler connections are clearly marked inside the boiler L N E (24hr LIVE).

The 24hr live is the permanent Feed connection to the boiler from the mains supply. External controls will require an independent fused spur supplied from the consumer unit, however this fused spur should be supplied by the same power source & protected by the same RCD as the boiler itself, the control circuit should be protected by a 6Amp MCB. The Boiler & control circuit RCD should be independent of all other domestic circuits. The boiler supply cable should be calculated by the means of a cable calculation in accordance with BS7671 by a suitably qualified electrician.

Boiler Protection

The recommended protection boilers are as follows:

Model No.	Boiler size	Protection
FUSION 48Kw	48kW BOILER	80 AMP Protection Per Phase
FUSION 36Kw	36kW BOILER	63 AMP Protection Per Phase
FUSION 14.4kW	14.4kW BOILER	80 AMP Protection
FUSION 12kW	12kW BOILER	63 AMP Protection
FUSION 9kW	9kW BOILER	50 AMP Protection
FUSION 6kW	6kW BOILER	32 AMP Protection

External controls

We recommend the use of the EHC SINGLE CHANNEL PROGRAMMER and ROOM THERMOSTAT for heating only installations.

For Heating and Hot water installations, we recommend the use of our "Twin Heat Pack" which includes the EHC ROOM THERMOSTAT & AN EHC 2 CHANNEL PROGRAMMER. The heat pack will incorporate all the relevant parts to comply with current building regulations i.e. Motorized valves to control the

heating and hot water circuits and Room and cylinder thermostats to control the room and water temperatures. This will also provide boiler interlock. The use of TRV's alone will not provide boiler interlock. We recommend the use of TRV's, however they must not be used in the room that has the room thermostat fitted.

Note: this control method is to comply with current building regulations provided by BEAMA (British Electrotechnical and Allied Manufacturers Association).

Programmer/Stat connections

The boiler PCB has a voltage free connection for the controls (RP). Under no circumstances should 240V be connected to the controller block as this will damage the boiler's PCB and Void the Manufacturers warranty.

The stat / programmer connections are clearly marked within the boiler.

Only after all connections have been made and checked should the system be filled with water and set to the proper pressure 1.5 bar (Sealed systems).

Check the system for leaks. If water leaks into the boiler this may damage the boiler electrics and the **manufacturers warranty will be invalid.**

Under no circumstances should the boiler be switched on when the system is dry.

The boiler has an inbuilt flow sensor. If the boiler has been switched on with a low or no water content, the system flow meter will sense this and prevent the boiler from sending power to the main elements.

If an off-peak electric meter has been installed by an Electricity Company to supply uninterrupted Off-Peak rate electricity at selected times, the appropriate settings should be entered into to the system programmer to take advantage of the OFF-peak rate electricity.

CONTROL PANEL WIRING CONNECTIONS

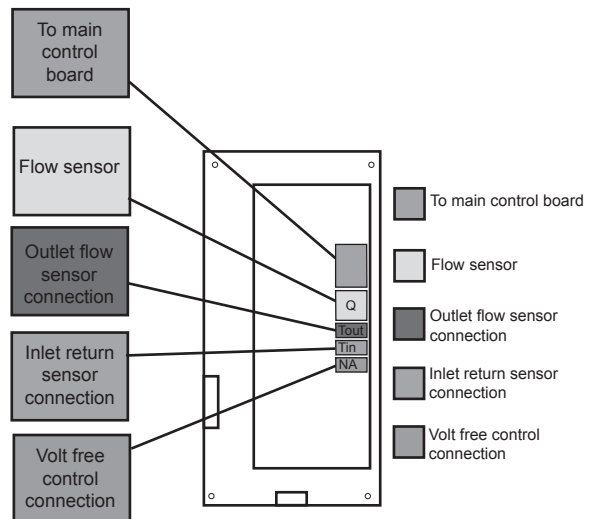

UNDER NO CIRCUMSTANCES SHOULD A VOLTAGE BE TAKEN TO THE NA OR RP CONNECTION AS THIS WILL DAMAGE THE CONTROL PCB AND INVALIDATE THE WARRANTY

EXTERNAL CONTROL WIRING

Heating Only Wiring (Non Standard Volt Free Switching)

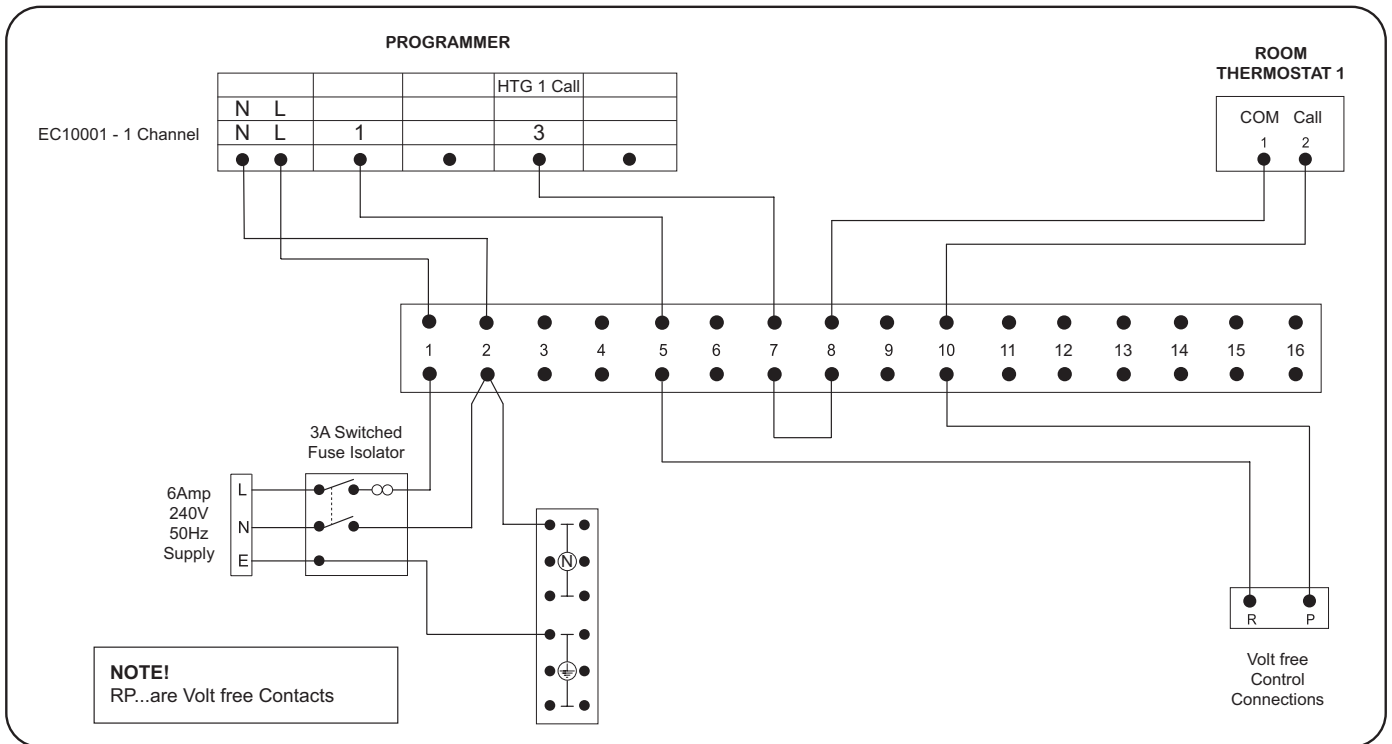

Heating & Hot Water Wiring: S Plan (Non Standard Volt Free Switching)

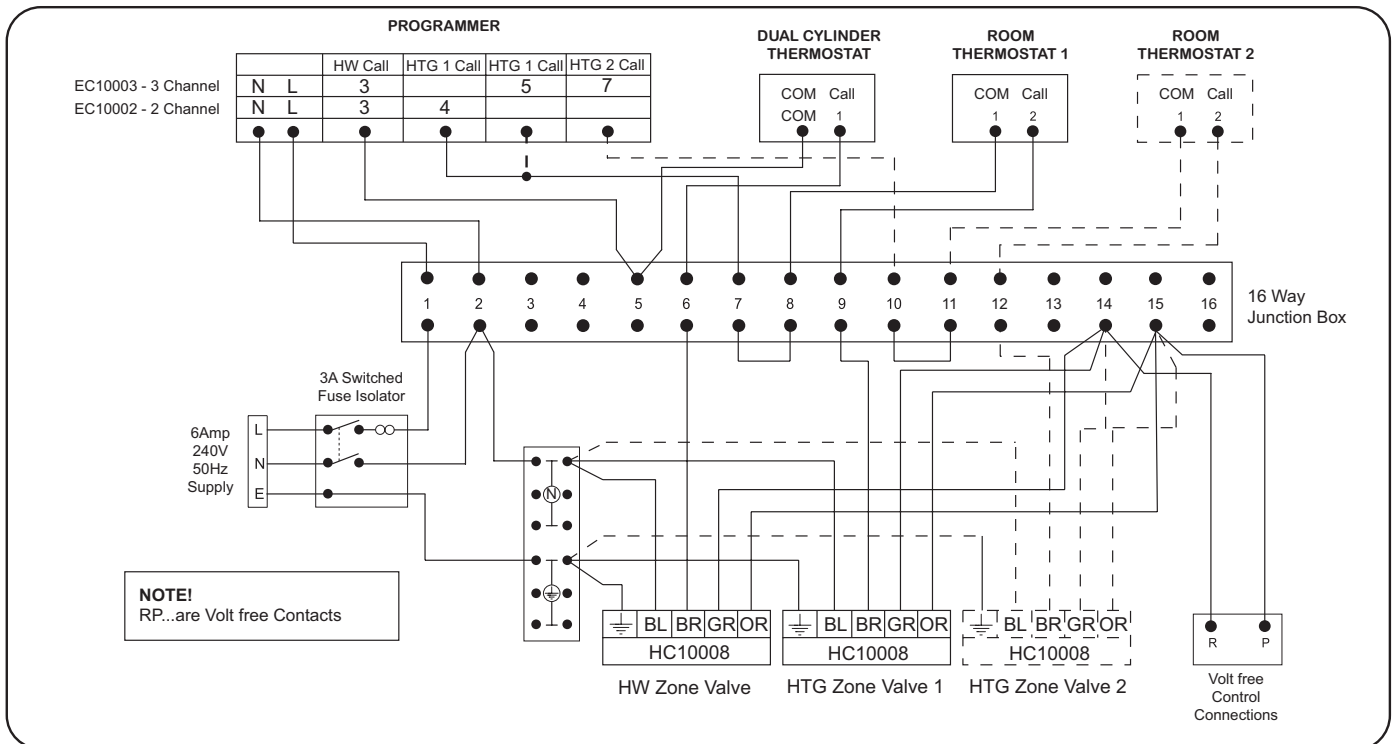

Product: EC10010
Description: 16 Way junction box

230V~10A 50Hz ClassII -15T55 BS6220 FIXED
WIRING MAX 1.5mm

Optional 2nd heating zone

INTERNAL BOILER WIRING

6, 9, 12, 14.4kw 240v~

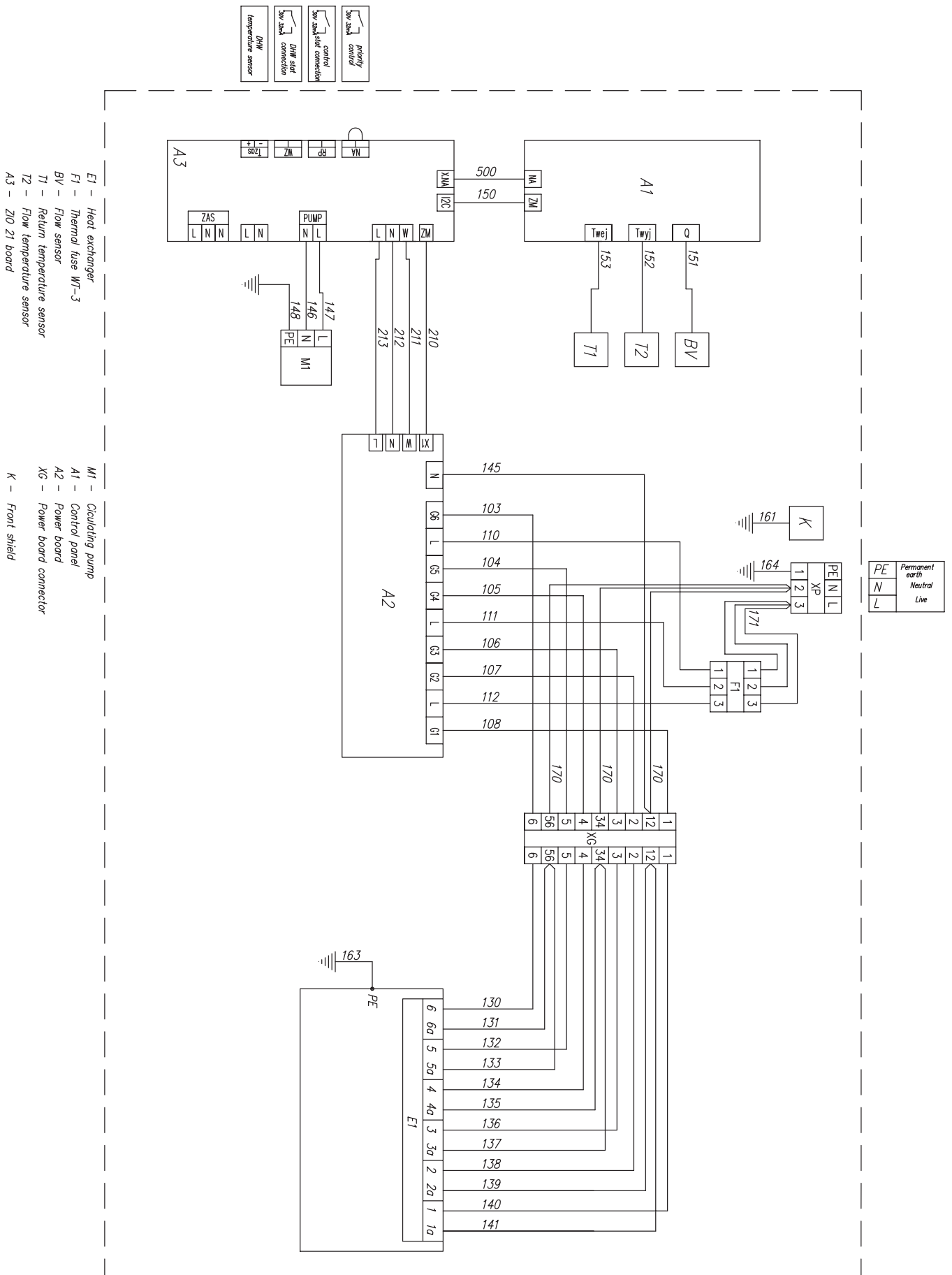

INTERNAL BOILER WIRING

36kW 415V~3N

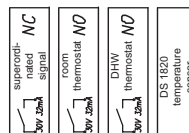
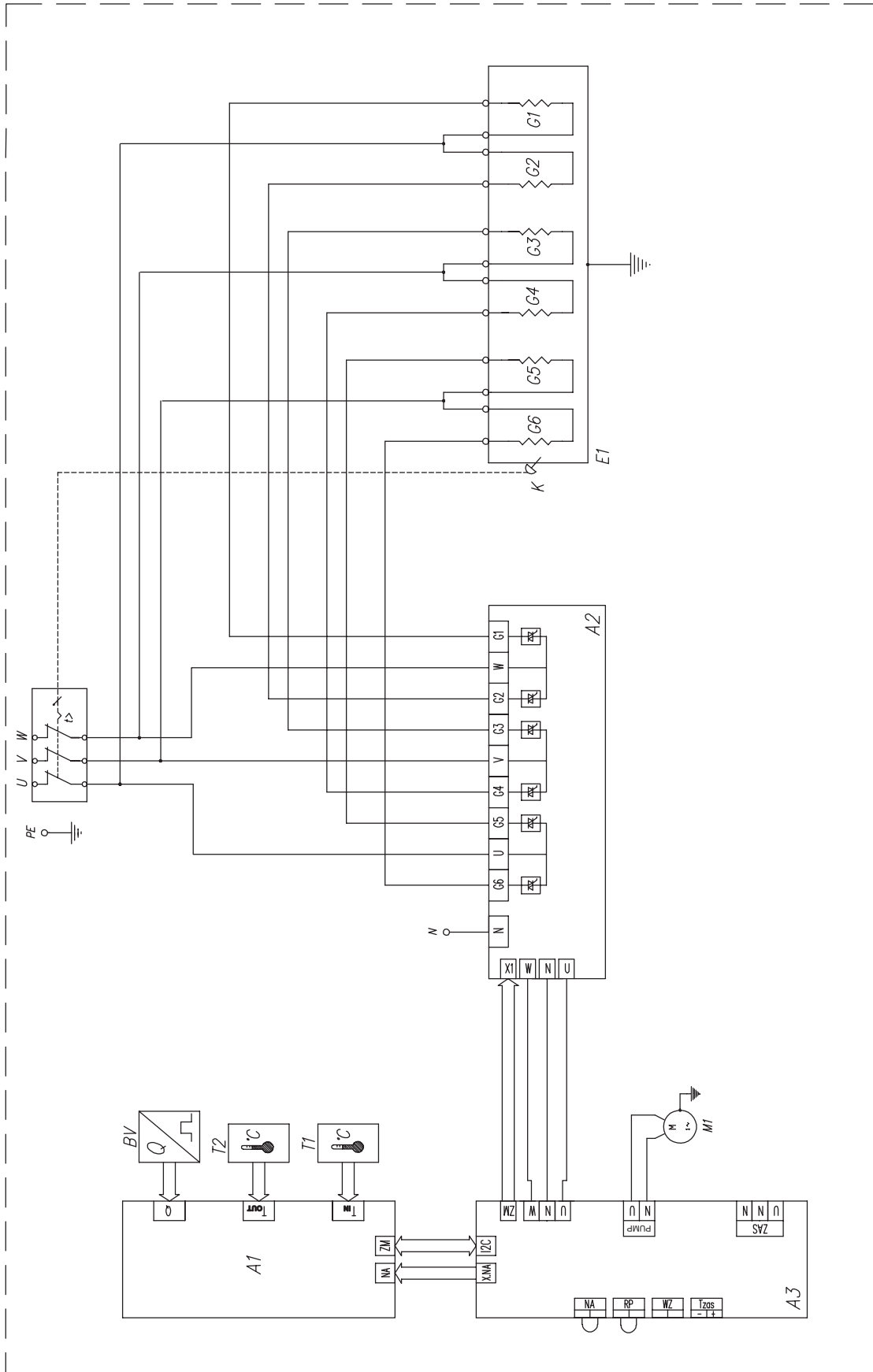

- E1 - heating box
- F1 - WT-3 safety cut-off
- BV - flow sensor
- T1 - inlet temperature sensor
- T2 - inlet temperature sensor
- A3 - ZIO-21 board
- M1 - Circulating pump
- A1 - Front panel
- A2 - Power board
- K - Capillary WT-3

INTERNAL BOILER WIRING

48kW 415V~3N

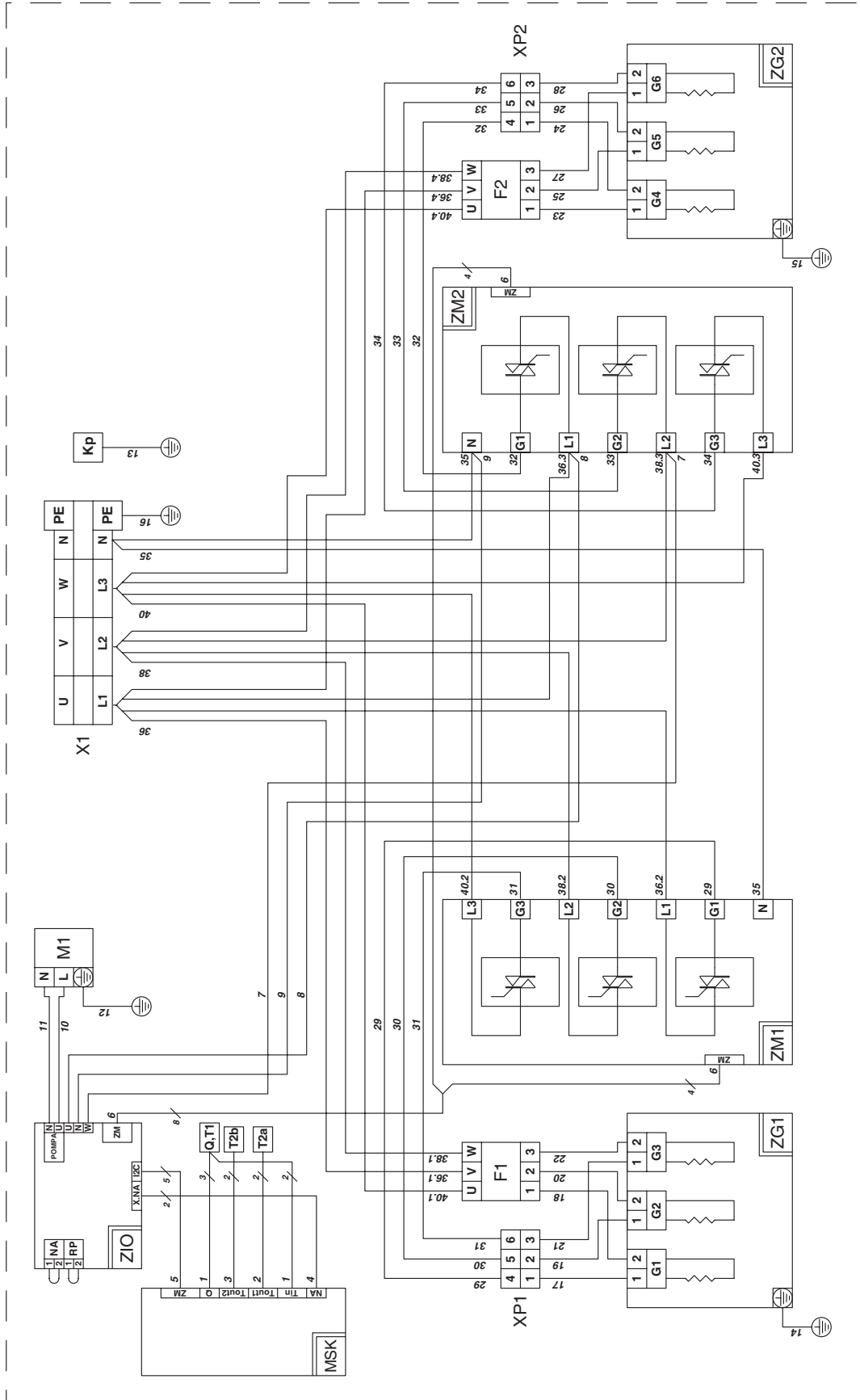

- X1 - electrical connection unit
- ZIO - board
- F1, F2 - thermal cut out WT-3
- MSK - control panel
- XP1, XP2 - terminal block
- T2a - temperature sensor on outlet(left)
- ZM1, ZM2 - heating unit
- T2b - temperature sensor on outlet(right)
- ZG1, ZG2 - heating box
- Q,T1 - flow sensor, temperature sensor on inlet
- M1 - circulation pump
- Kp - front cover

EXTERNAL BOILER WIRING

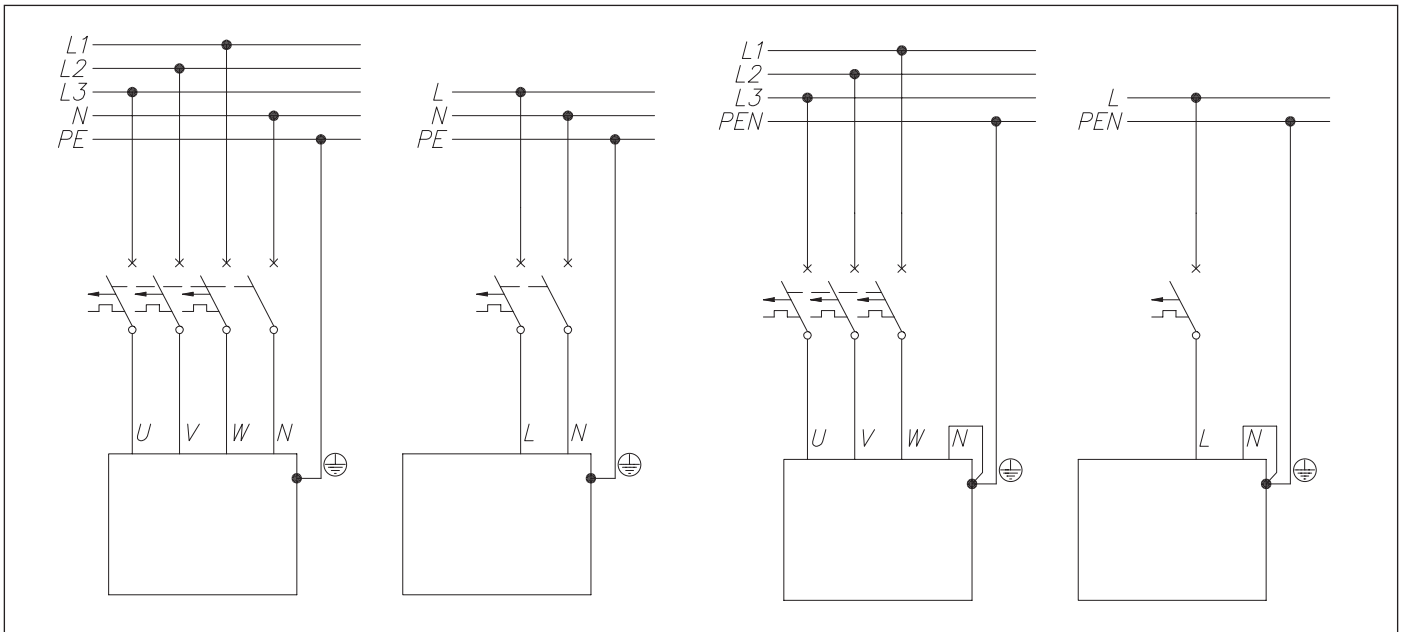

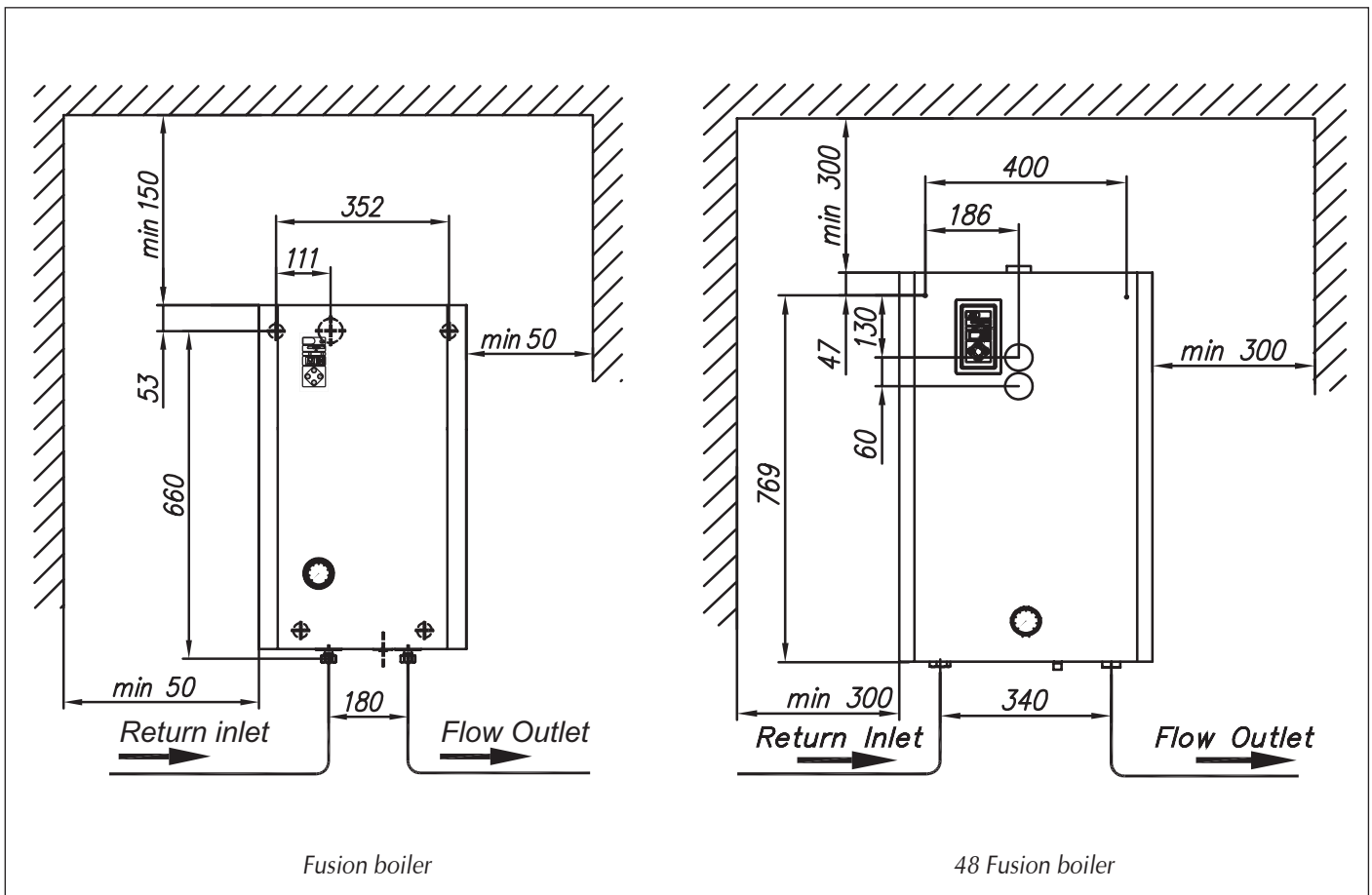

BOILER DIMENSIONS



USER INSTRUCTIONS

Unlike other system boilers such as Gas, Oil and Propane, the FUSION range of electric boilers require no ignition or lighting sequence to be executed by the end user. All the end user is required to do is ensure that the system is filled with water and the room stat or programmer is calling for heat.

I. Boiler operation

- 1.1 Switch on unit power supply. Press  to switch the boiler on. Switch the boiler off using the same  switch by holding it for 2 seconds.
- 1.2 Switch on programmer or room stat to call for heat.
- 1.3 When the system reaches the required boiler set point temperature the boiler will modulate and will automatically stage down.
- 1.4 Modulation - this is when the boiler controls the heating load and the power that is required to maintain the relevant temperature setting.
- 1.5 During the periods when the boiler is switched off the pump will operate every day for 15 minutes. This protects the boiler and the central heating system from being blocked and silted up.

2. Temperature Setting

We recommend boiler temperature to be set to 65°C. Raise and lower the temperature in your installation with the use of the switches and. Refer to the diagram opposite to learn how to adjust the right temperature to make the boiler work comfortably and economically.

ATTENTION: Should the temperature on the front panel be set on too low value the boiler will not reach the required room temperature.

Working parameters control

You can check all the working parameters of the boiler by pressing.

First pressing of  switch - inlet temperature displayed (indicators „D” and „E” on).

Next pressing of  switch - outlet temperature displayed (indicators „F” and „E” on).

Next pressing of  switch - medium (water) rate of flow displayed (indicator „H” on).

Next pressing of  switch - power with which the boiler currently heats (indicator „I” on).

Next pressing of  switch - returns to the „standard” state, where you can change the temperature setting in the central heating system.

NOTE: The indicators not only describe the state of the boiler but also inform about failures.

3. Front Control Panel

- Indicator B When GREEN light is on the pump is operating. When this light flashes the flow rate is insufficient (less than 5 l per min) Refer to technical specifications.
- Indicator C When light is off room thermostat temperature has been achieved. (RP is open) When the green light flashes the NA connection is open. When RED light is on, the boiler is operating When GREEN light is on boiler temperature has been achieved.
- Indicator F Set Temperature.
- Indicator D Return Temperature. When this indicator flashes the return temperature sensor is faulty.
- Indicator E Flow Temperature. When this indicator flashes the flow temperature sensor is faulty.
- Indicator G Press to show Flow, Return and Set Temperature.
- Indicator H Press to check flow rate.
- Indicator I Press to check power consumption.
- Indicator A DHWC Indicator.
- Indicator K DHWC temperature indicator (when electronic DHWC temperature sensor is used).

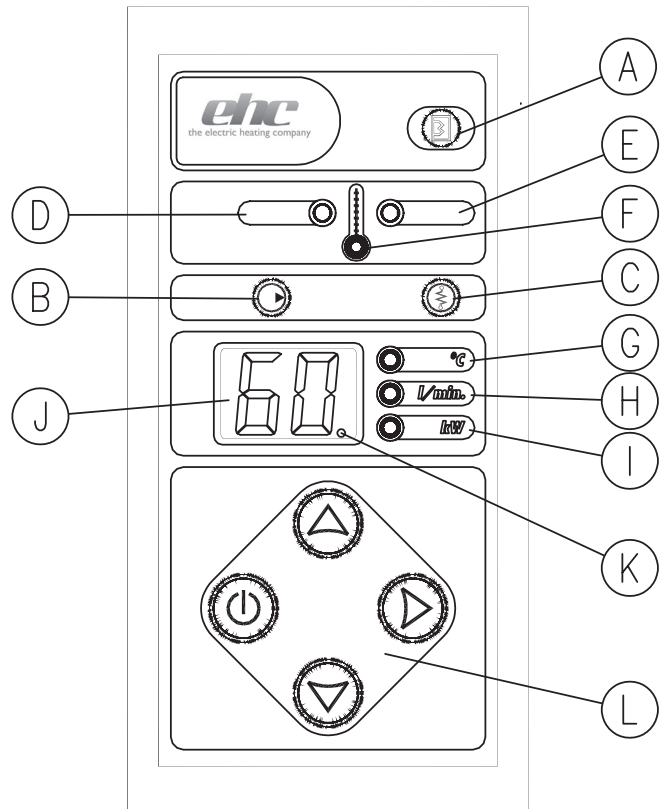

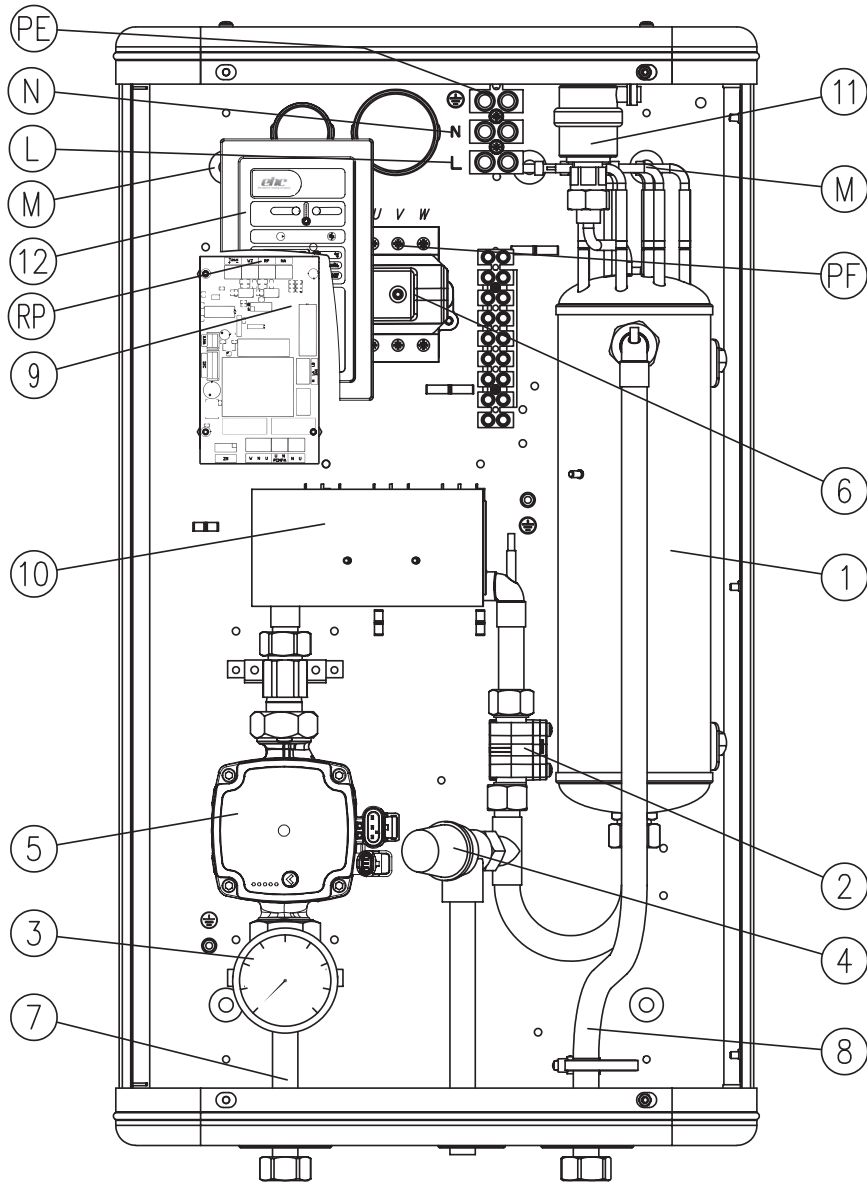

Slimline boiler

- 1 - heat exchanger
- 2 - flow sensor
- 3 - pressure gauge
- 4 - safety valve
- 5 - circulating pump
- 6 - safety temperature limiter
- 7 - return inlet
- 8 - flow outlet
- 9 - ZIO board
- 10 - power board
- 11 - automatic vent
- 12 - PSK control board
- PF - 3 phase electric mains connection (phases)
- PN - electrical connections
- L - live
- PE - permanent earth
- N - neutral
- M - boiler fixing positions
- RP - control stat connections

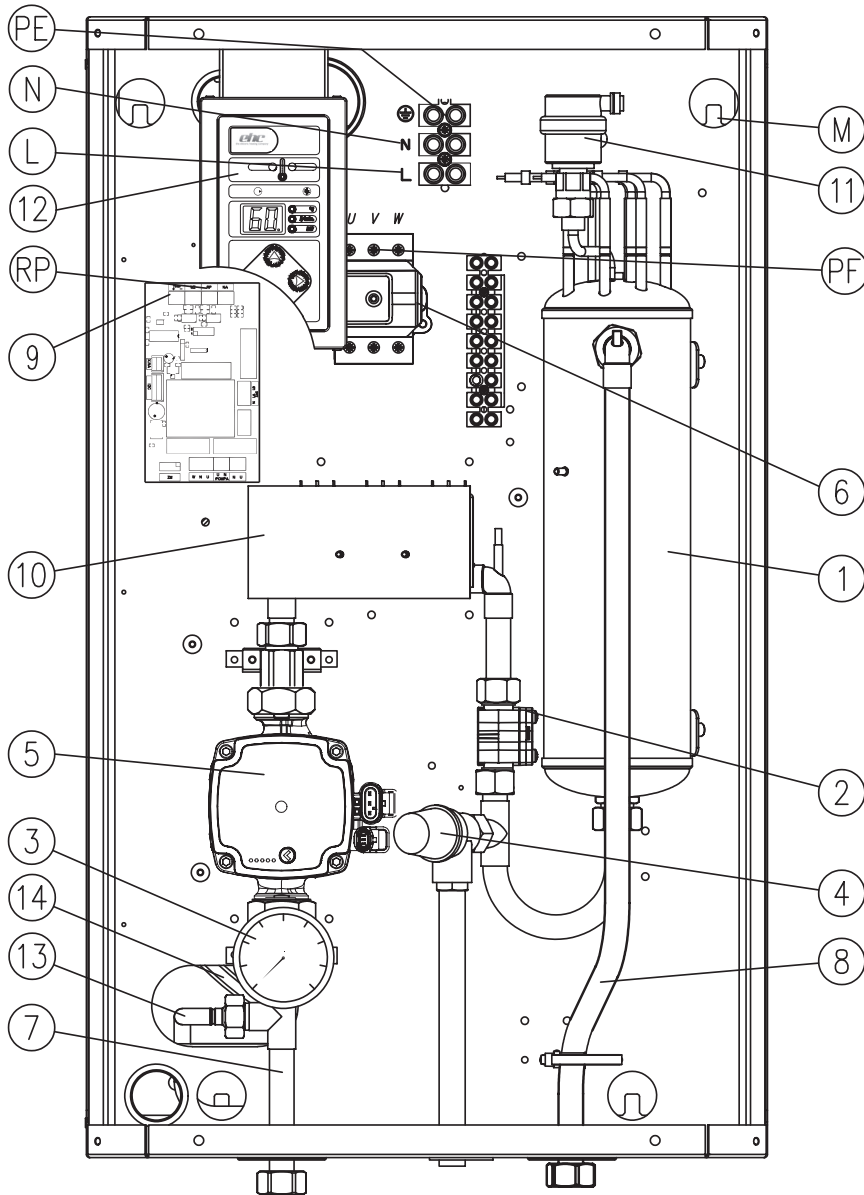

Fusion boiler

- 1 - heat exchanger
- 2 - flow sensor
- 3 - pressure guage
- 4 - safety valve
- 5 - circulating pump
- 6 - safety temperature limiter
- 7 - return inlet
- 8 - flow outlet
- 9 - ZIO board
- 10 - power board
- 11 - automatic vent
- 12 - PSK control board
- 13 - expansion vessel connection
- 14 - expansion vessel
- PF - 3 phase electric mains connection (phases)
- PN - electrical connections
- L - live
- PE - permanent earth
- N - neutral
- M - boiler fixing positions
- RP - control stat connections

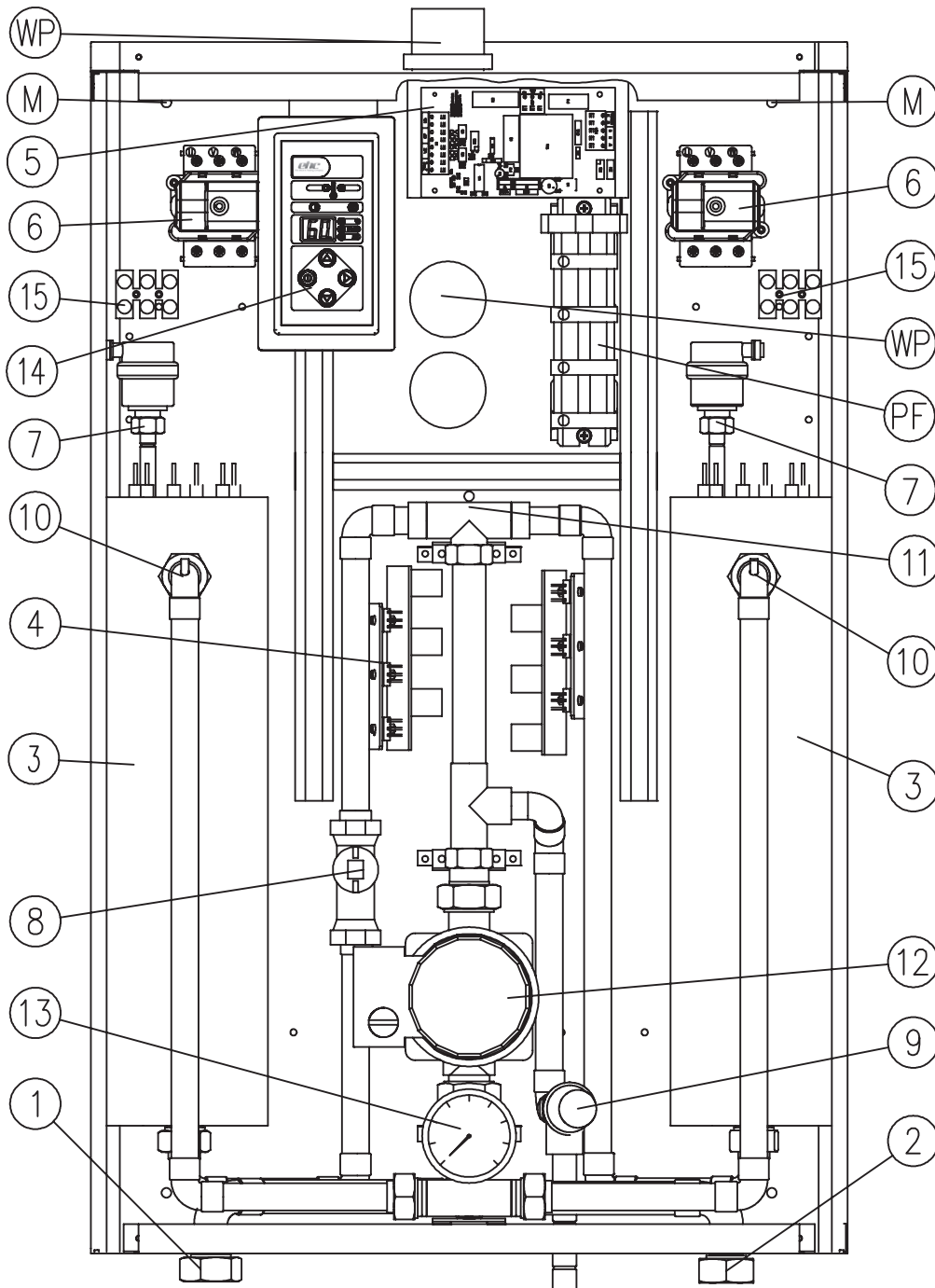

48 Fusion boiler

- [1] - water inlet (return)
- [2] - water outlet (flow)
- [3] - heat exchanger
- [4] - power board
- [5] - ZIO board
- [6] - safety temperature limiter
- [7] - automatic vent valve
- [8] - vortex flow sensor
- [9] - safety valve
- [10] - outlet temperature sensor
- [11] - inlet temperature sensor
- [12] - circulating pump
- [13] - pressure guage
- [14] - PSK control board
- [15] - electrical connector
- PF - phase conductors connection point
- WP - electric cable-bush
- M - boiler fixing positions

FAULT FINDING

Symptom	Reason	Procedure
The indicators on the front panel are off	No power to the boiler	Check electricity mains power supply
	Main over heat stat cut-out	Check the power board fuse F2 Check the WT3 temperature safety cut-out investigate cause - possibly fault / return sensors
The „B“ indicator is flashing	Flow sensor is blocked	Check flow sensor
		The central heating system airlock - vent the central heating system and the pump
	Circulating pump is blocked	Check for choked pipes
	Flow sensor failure	Move the pump rotor manually
The room thermostat indicates that the boiler is switched on. „C“ indicator does not light	Control panel fuse failure	Check the flow sensor and replace if necessary.
		Find the failure reason then replace the fuse.
The „D“ or „E“ indicator are flashing	Temperature sensor failure	Check external controls, room stats, etc. are calling for heat. Link out control stats connections to eliminate external controls
		If boiler operates the fault is with the external controls
		Replace temperature sensor.

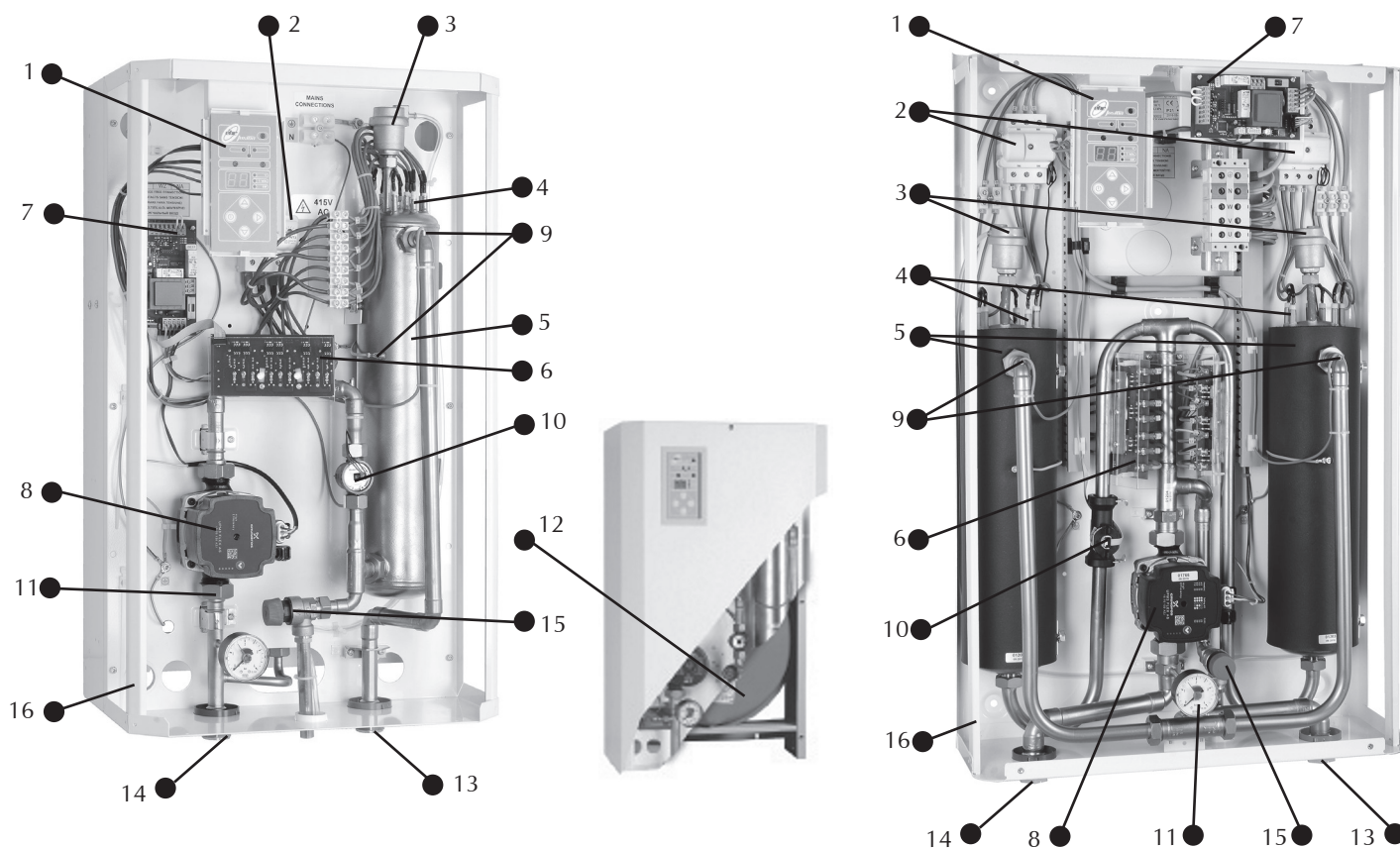

boiler key

- | | |
|-------------------------------------|----------------------------|
| 1. Control Panel | 9. Flow & Return Sensors |
| 2. Over Heat Stat | 10. Flow Switch |
| 3. Automatic Air Vent | 11. Pressure Gauge |
| 4. Heating Elements | 12. Expansion Vessel |
| 5. Heat Exchanger | 13. Heating Flow |
| 6. Printed Circuit Board | 14. Heating Return |
| 7. Voltage Free Control Connections | 15. Pressure Relieve Valve |
| 8. Circulation Pump | 16. Enclosure |

TECHNICAL SPECIFICATIONS

Boiler range	Fusion EHC FUS 6kW	Fusion EHC FUS 9kW	Fusion EHC FUS 12kW	Fusion EHC FUS 14,4kW	Fusion EHC FUS 36kW	Fusion EHC FUS 48kW
Pipe entry from boilers	Bottom Entry	Bottom Entry	Bottom Entry	Bottom Entry	Bottom Entry	Bottom Entry
Central heating flow & return pipes	22 mm					28 mm
Min water pressure	1 bar					
Max water pressure	3 bar					
Expansion vessel	6 lt.					48kw no expansion vessel fitted
	maximum system water volume about 60 litres at initial system pressure 1,5 bar					
Vessel charge pressure	1,5 bar					
Overall dimensions (height x width x depth)	700 x 420 x 285					
Dry weight	25kg					29kg
Electrical supply	240V 1ph 50Hz					
Load/current	240V; 25,0 A	240V; 37,5 A	240V; 50,0 A	240V; 60,0 A	415V; 50,1 A	415V; 66,7A
Heating output	20,478 Btu	30,717 Btu	40,956 Btu	49,147 Btu	122,837 Btu	163,782 Btu
Max temp setting	85°C					
Min temp setting	40°C					
Overheat Protection	100°C					
Pump included	Yes					
Recommended Pump settings	Set to system kW rating (See page 6)					
Protection	32 A	50 A	63 A	80 A	63 A	80A
The maximum allowed network impedance	0,39 Ω	0,32 Ω	0,24 Ω	0,22 Ω	0,09 Ω	0,03 Ω
ERP Rating						

NB: Voltage free control connections

Controls

Central Heating Only:
 EHC Single Channel Heat Pack
 Central Heating & Domestic Hot Water:
 EHC Twin Channel Heat Pack



Boiler Dimensions

Slimline	FUSION
Width 380mm	Width 420mm
Height 660mm	Height 700mm
Depth 175mm	Depth 285mm

48 FUSION
Width 503mm
Height 815mm
Depth 197mm



Electric Heating Company Ltd

Unit 40, Block 5
Third Road
Blantyre Industrial Estate
Blantyre
Glasgow

G72 0UP

Tel: 01698 820533 Fax: 01698 825697

www.electric-heatingcompany.co.uk

(Waste Electrical & Electronic Equipment)

(Applicable in the European Union and other European countries with separate collection systems).

This marking shown on the product or its literature, indicates that it should not be disposed of with other household wastes at the end of its working life.

To prevent possible harm to the environment or human health from uncontrolled waste disposal, please separate this from other types of wastes and recycle it responsibly to promote the sustainable reuse of material resources. Household users should contact either the retailer where they purchased this product, or their local government office, for details of where and how they can take this item for environmentally safe recycling.

Business users should contact their supplier and check the terms and conditions of the purchase contract. This product should not be mixed with other commercial wastes for disposal.

