

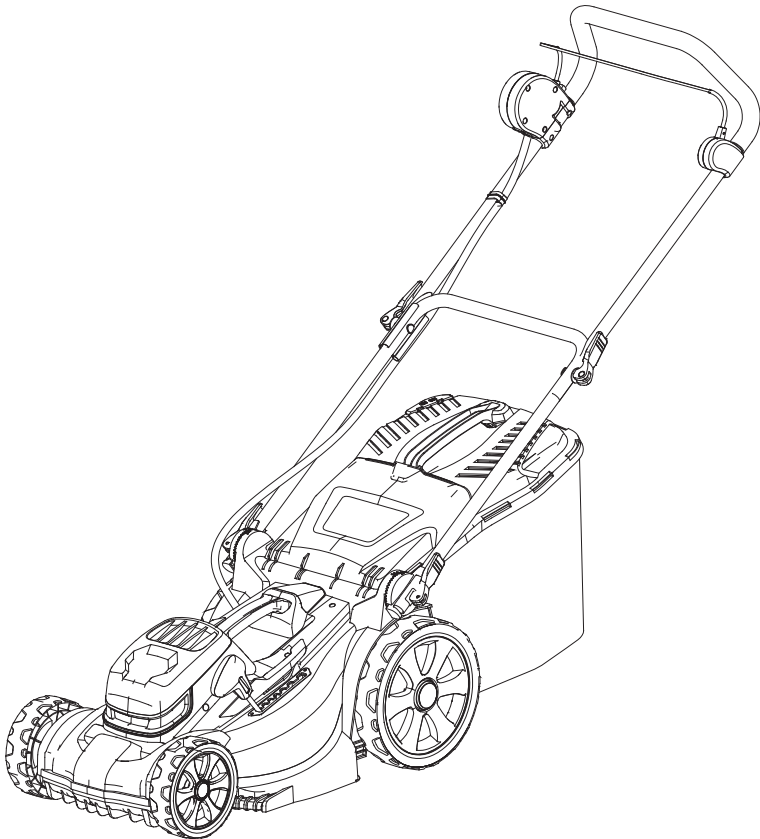

Original User's Instructions

2x18V 40cm Brushless Cordless Lawn Mower

SKU: 23984



READ BEFORE USE

PLEASE KEEP THESE INSTRUCTIONS FOR FURTHER REFERENCE

CONTENT

• WHAT'S IN THE BOX -----	3
• SPECIFICATIONS -----	4
• EXPLANATIONS AND SYMBOLS, CAUTIONS AND WARNINGS -----	5
• IMPORTANT SAFETY WARNINGS -----	7
• PRODUCT DESCRIPTION AND IDENTIFICATIONS -----	16
• ASSEMBLY AND OPERATING INSTRUCTIONS -----	17
• CARE AND CLEANING -----	27
• TROUBLE SHOOTING -----	30
• DECLARATION OF CONFORMITY / PERFORMANCE -----	31
• ENVIRONMENTAL INFORMATION -----	32
• GUARANTEE -----	33
• CUSTOMER SUPPORT -----	33

WHAT'S IN THE BOX

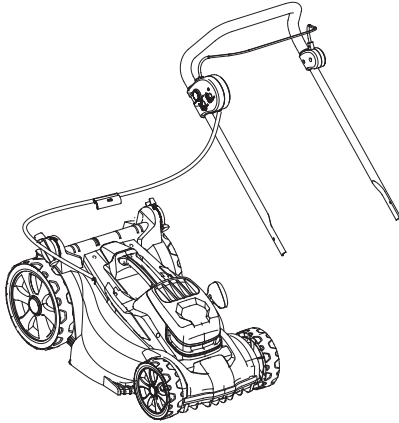

Lawn mower with upper handle

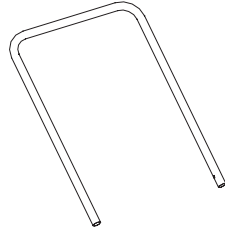

Lower handle

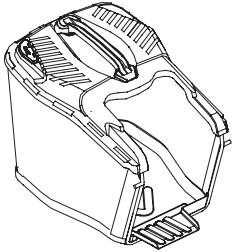

Grass collection bag



Lower handle quick release lever x 2



Teeth clamp x 2



Upper handle quick release lever (curved bolt head) x 2



Cable clip x 2

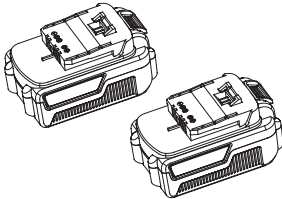

Battery pack x 2

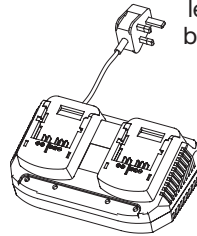

Charger

If you do not have all these items, please contact:
www.coreservice.co.uk
Hotline: +44 01904 947568
Email support@coreservice.co.uk

SPECIFICATION

Technical Data	
Model	Y0J-SP03-4036ZA
Nominal voltage of product with battery	36V d.c. (2X18V 4AH)
No-load cutting speed	3400/min
Cutting width	40cm
Cutting height	25-75mm, 7 positions
Capacity of grass bag	45L
Net weight approx.	13.4kg
Measured sound pressure level(L _{pA})	79.1dB(A), K=3dB(A)
Measured sound power level(L _{wA})	94.62dB(A), K=1.14dB(A)
Guaranteed sound power level	96dB(A)
Vibrations	1.89m/s ² K=1.5m/s ²
Battery pack model	B0P-SP06-18ZK
Battery capacity	4.0Ah
Battery charging time Max.	120min
Battery charger model	B0Q-SP07-2040ZB
Battery charger input	220-240V~, 50/60Hz 120W
Battery charger output	21V d.c. 4A
Protection class	Class II / 

Note: The above specifications are the MAXIMUM capacities of the tool. Voltage measured without workload. Initial battery voltage reaches 20 Volts. Nominal voltage is 18 Volts.

EXPLANATIONS AND SYMBOLS, CAUTIONS AND WARNINGS



To reduce the risk of injury, the user must read the instruction manual carefully.

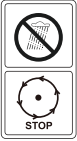

Avoid using the machine in the rain.

Wait until all machine components have completely stopped before touching them.



Keep bystanders away. Objects thrown by the product could hit the user or other bystanders. Always ensure that other people and pets remain at a safe distance from the product when it is in operation.



Beware of sharp blades. Blades continue to rotate after the motor is switched off. Remove disabling device before performing any maintenance tasks.



Guaranteed sound power level value is 96 dB.



Wear ear protection, eye protection and protective gloves (PPE) when using the product.



UK conformity assessed



WEEE symbol. Waste electrical products should not be disposed of with household waste. Please recycle where facilities exist. Check with your local authority or local store for recycling guidelines.



The product complies with the applicable European directives and an evaluation method of conformity for these directives was done.



Do not throw into water.



Do not throw on fire.



Do not subject the battery to strong sunlight over long periods of time. Do not leave on a heater (max. 45°C).



Batteries contain Li-ion. Do not dispose of waste batteries in domestic waste. Contact local authority to find out how to dispose of batteries.

Li-Ion



The charger is for indoor use only.



Double insulation.



Protective 5A limited.

IMPORTANT SAFETY WARNINGS

General Safety Instructions



Warning: Please read the following instructions carefully, failure to do so could lead to serious personal injury. When using the electric lawnmower, basic safety precautions, including the following, should always be followed to reduce the risk of fire, electric shock and personal injury. Read all these instructions before operating this product and save these instructions.

Become familiar with the owner's manual before attempting to operate this machine.

- This appliance is not intended for use by persons (including children) with reduced physical, sensory or mental capabilities, or lack of experience and knowledge, unless they have been given supervision or instruction concerning use of the appliance by a person responsible for their safety.
- Children should be supervised to ensure that they do not play with the appliance.
- The appliance is only to be used with the power supply unit provided with the appliance.

Important! Read carefully before use, keep for further reference.

Training

- Read the instructions carefully. Be familiar with the controls and the proper use of the equipment.
- Never allow children or people unfamiliar with these instructions to use the lawnmower. Local regulations can restrict the age of the operator.
- Never mow while people, especially children, or pets are nearby.
- Keep in mind that the operator or user is responsible for accidents or hazards occurring to other people or their property.

Preparation

- While mowing, always wear substantial footwear and long trousers. Do not operate the equipment when barefoot or wearing open sandals.
- Thoroughly inspect the area where the equipment is to be used and remove all objects which can be thrown by the machine.
- Before using, always visually inspect to see that the blades, blade bolts and cutter assembly are not worn or damaged. Replace worn or damaged blades and bolts in sets to preserve balance. Replace damaged and unreadable labels.
- Ensure the switch is in the off position before inserting the battery pack. Inserting the battery pack into a machine that is switched on can result in injury.

Product Safety Warnings

General Operation

- Use the tool only with specifically designated battery packs. Use of any other battery packs will increase the risk of injury and fire.

- Only operate the product in daylight or in good artificial light.
- Do not expose tool and charger to rain or wet conditions. If a tool or charger is exposed to moisture it will increase the risk of electric shock, battery damage, fire or explosion.
- Avoid operating the product on wet grass.
- Always be sure of your footing on slopes.
- Walk, never run.
- Mow across the face of slopes, never up and down.
- Exercise extreme caution when changing direction on slopes.
- Do not mow excessively steep slopes.
- Use extreme caution when reversing or pulling the product towards you.
- Stop the blades if the product has to be tilted for transportation, when crossing surfaces other than grass and when transporting the product to and from the area to be mowed.
- Never operate the product with defective guards or shields or without safety devices in place such as deflectors or grass collection bag. When switching on motor keep feet well away from blades.
- Do not tilt the product when switching on the motor, except if the product has to be tilted for starting. In this case, do not tilt it more than absolutely necessary and lift only the part furthest away from the operator.
- Do not start the product when standing in front of the discharge opening.
- Do not put hands or feet near or under rotating parts.
- Keep clear of the discharge opening at all times.
- Do not transport the product while the cutting blade is running.

- Stop the product and remove the safety key/battery pack from the machine and make sure that all moving parts have come to a complete stop:
 - ▶ Whenever you leave the product unattended.
 - ▶ Before clearing blockages or unclogging chute.
 - ▶ Before checking, cleaning or working on the product.
 - ▶ After striking a foreign object. Make sure to inspect the product for damage and make repairs before restarting and operating the product.
- If the product starts to vibrate abnormally:
 - ▶ Inspect for any damages.
 - ▶ Replace or repair any damaged parts.
 - ▶ Check for and tighten any loose parts.

Safety Warning For Battery Pack

- Fully charge battery pack before the first use.
- Recharge battery pack when the power output starts to slow. Do not continue to use product when battery capacity level is low.
- To prevent serious damage to the battery pack, charge in temperatures above 5°C or below 45°C. Longest life and best performance can be achieved when battery is charged at room temperature (20 °C ± 5 °C).
- If the battery temperature is hot after use, it must be allowed to cool before putting it into the charging station.
- If the battery pack becomes too hot during charging, disconnect and switch off immediately. Contact the service center directly.
- **Do not dismantle, open or shred cells or battery pack.**

- **Do not short-circuit a battery pack.** Do not store battery packs haphazardly in a box or drawer where they may short-circuit each other or be short-circuited by conductive materials. **When battery pack is not in use, keep it away from other metal objects, like paper clips, coins, keys, nails, screws or other small metal objects, that can make a connection from one terminal to another. Shorting the battery terminals together may cause burns or a fire.**
- Do not carry individual battery packs in your pockets or bag as they could short-circuit against other metal items.
- Do not expose battery pack to heat or fire. Avoid use or storage in direct sunlight for extended periods of time.
- Do not subject battery pack to mechanical shock.
- In the event of battery leaking, do not allow the liquid to come into contact with the skin or eyes. If contact has been made, wash the affected area with copious amounts of water and seek medical advice.
- Should a Li-ion battery catch fire, ensure to use the correct fire extinguisher to combat the fire. Do not throw or spray water on a burning Li-ion battery.
- Keep battery pack clean and dry. Wipe the battery pack terminals with a clean dry cloth if they become dirty.
- Battery pack needs to be charged before use. Always refer to this instruction and use the correct charging procedure.
- Do not maintain battery pack on charge when not in use.
- After extended periods of storage, it may be necessary to charge and discharge the battery pack several times to obtain maximum performance.
- Battery pack gives its best performance when it is operated at normal room temperature (20 °C ± 5 °C).
- When disposing of battery packs, keep battery packs of different electrochemical systems separate from each other.

- Recharge only with the charger specified by manufacturer. Do not use any charger other than that specifically provided for use with the equipment. A charger that is suitable for one type of battery pack may create a risk of fire when used with another battery pack.
- Do not use any battery pack which is not designed for use with the equipment.
- Keep battery pack out of the reach of children.
- Retain the original product literature for future reference.
- Remove the battery from the equipment when not in use.
- Dispose of properly.
- Do not mix cells of different manufacture, capacity, size or type within a device.
- Do not remove battery pack from its original packaging until required for use.

Safety Warning For Battery Charger

- Charge only battery pack of the same model provided by manufacturer and of models recommended by manufacturer.
- Do not use the original charger on other Li-ion batteries or on any other type of battery as this can increase the risk of fire or explosion.
- Check the battery charger, cable and plug before each use. Do not use the battery charger if damaged. Do not open the battery charger yourself, charger must be repaired by qualified personnel using original spare parts.
- The charger is designed to use a standard household 220-240 V~ 50Hz power source, ensure that the plug matches the outlet.
- Never modify the plug in any way, this will reduce the risk of electric shock.

- Do not abuse the cord of charger. Never use the cord for carrying, pulling or unplugging the charger. Keep cord away from heat, oil, sharp edges or moving parts. Damaged or entangled cords increase the risk of electric shock.
- Make sure the charger cord is situated so that it will not be stepped on, tripped over or get damaged.
- If the supply cord is damaged, it must be replaced by the manufacturer, its service agent or similarly qualified persons in order to avoid a hazard.
- Keep the battery charger clean. Contamination can increase the risk of electric shock.
- Protect the battery charger from rain and moisture. If water accesses the battery charger there is an increased risk of electric shock.
- Battery will heat up whilst charging. When charging batteries, ensure that the battery charger is in a well-ventilated area and to reduce the risk of fire, do not operate battery charger on or close to inflammable materials such as paper or textiles.
- Do not overcharge any batteries. Ensure that batteries and chargers are not left unsupervised during charging.
- The temperature range over which the battery pack can be charged is typically between 5°C-45°C. Attempts to charge out with the prescribed temperature range may automatically be blocked by the protection circuitry of the battery pack. Longest life and best performance can be obtained if the battery pack is charged at room temperature.
- Disconnect charger from the power supply when not in use. This will reduce the risk of electric shock or damage to the charger.

- This charger can be used by children aged from 8 years and above and persons with reduced physical, sensory or mental capabilities or lack of experience and knowledge if they have been given supervision or instruction concerning use of the appliance in a safe way and understand the hazards involved.
- Children shall not play with the appliance. Cleaning and user maintenance shall not be made by children without supervision.

Maintenance and Storage

- Always allow the product to cool down before storing. Disconnect the machine from the power supply (e.g., remove the battery pack from the machine) before carrying out maintenance or cleaning work.
- Keep all nuts, bolts and screws tight to be sure the product is in a safe working condition.
- Check the grass collector frequently for wear or deterioration.
- Be careful when adjusting the product to prevent trapping fingers between moving blades or other fixed parts of the product.
- When servicing the blades be aware that even though the power source is switched off, the blades can still move.
- Replace worn or damaged parts for safety. Use only genuine replacement parts and accessories.
- Do not attempt to open the charger and battery pack. There are no customer serviceable parts inside. Return to any authorized service center.
- Store the appliance with battery pack fully charged at room temperature. When not in use, store the machine out of the reach of children.

- Every deep discharge cycle decreases the capacity of battery pack. To prolong battery life, it is recommended that you charge the battery every six months within extended periods of time when the product is not in use.
- Have your tool repaired by an authorized service agent. This tool is manufactured in accordance with the relevant safety regulations. To avoid danger, equipment must only be repaired by qualified technicians.
- Only use parts and accessories made for this machine by the manufacturer. Failure to do so can result in personal injury.

PRODUCT DESCRIPTION AND IDENTIFICATIONS

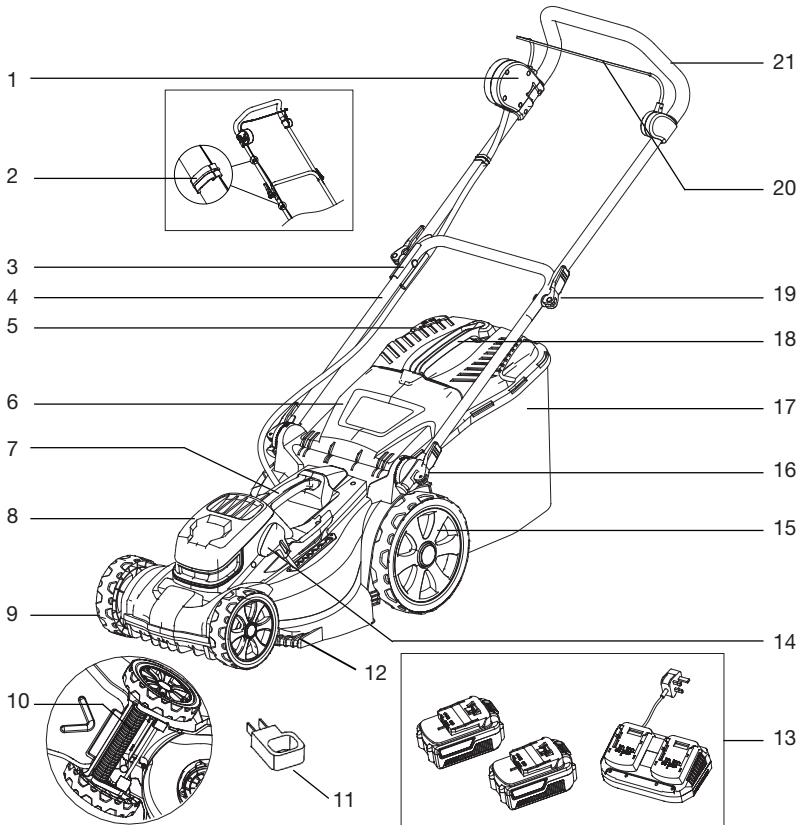

- | | |
|---|---|
| 1. Switch box with on/off button | 12. Grass comb |
| 2. Cable clip x 2 | 13. Battery pack + Charger |
| 3. Power cord protection sheath | 14. Cutting height adjustment lever |
| 4. Lower handle | 15. Rear wheel |
| 5. Grass full indicator | 16. Lower handle quick release lever |
| 6. Safety flap | 17. Grass collection bag |
| 7. Carry handle | 18. Carry handle for grass collection bag |
| 8. Battery pack compartment cover | 19. Upper handle quick release lever |
| 9. Front wheel | 20. Switch lever |
| 10. Roller | 21. Top handle |
| 11. Safety key(in the battery pack compartment cover) | |

Not all the accessories illustrated or described are included in standard delivery.

ASSEMBLY AND OPERATING INSTRUCTIONS



NOTE: To reduce the risk of injury, user must read instruction manual.

Intended Use

This product is intended for domestic lawn mowing.



WARNING: Before assembly and adjusting to the mower, ensure the mower is turned off and the battery pack is removed.



WARNING: Ensure the battery pack is disconnected from the mower before making the assembly.

Attach the lower handle

Attach the two locking cams to the lower handle.

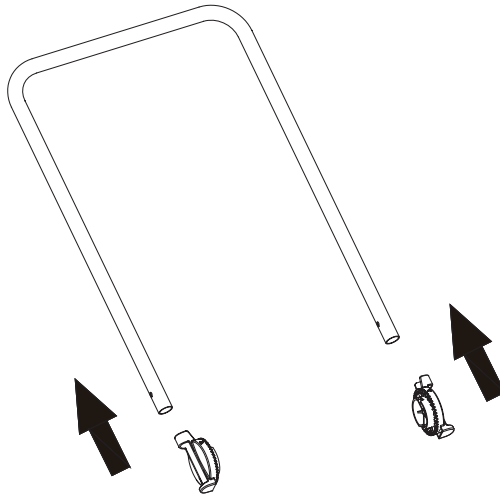

Attach the lower handle to the lawn mower

Mount the locking cams on the lower handle (4) onto the clamp base on the machine. There are 3 angle marking lines on the tooth cams base. Carefully align the mark arrow on the tooth cams to the corresponding angle marking line on both sides. The lower handle (4) angle can be adjusted by aligning the mark arrow to different angle marking lines for desired operation angles.

Insert the lower handle quick release lever (16) bolt into the hole on each side. Rotate the levers counter clockwise for 5 or 6 times then push the lever onto the lower handle bars to securely locking the clamps in place.

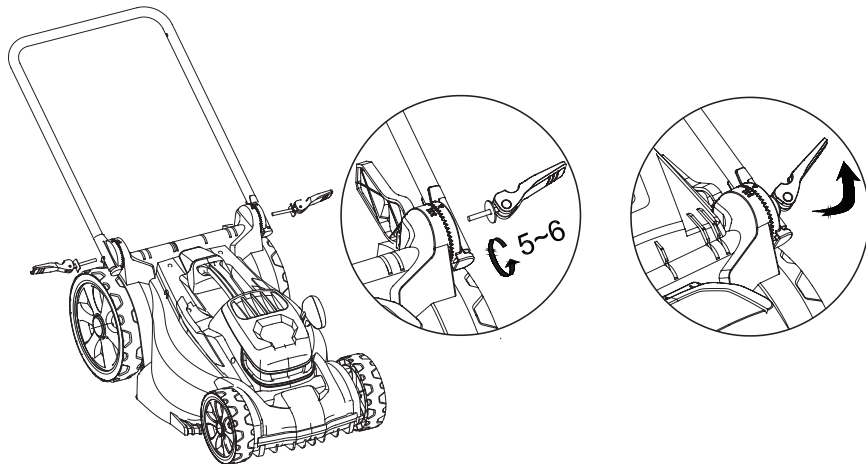

Attach the top handle to the lawn mower

Loosen the upper handle quick release lever (curved bolt head)(19) separately with locking lever, gasket and bolt.

Attach the upper handle onto the lower handle from outside of the lower handle and align the holes in order with locking lever, washer, upper handle and lower handle (4).

Assemble them with the upper handle quick release levers(19). (Refer to figure below)

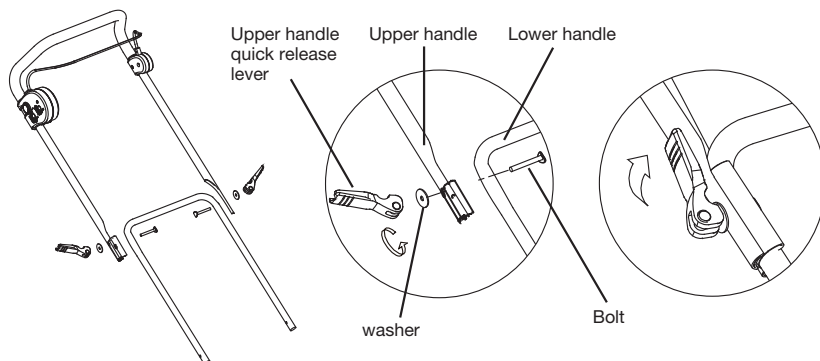

Fitting the cable clip

Ensure that the cable clips(19) supplied are used to fix the cable to the lower handle and upper handle.

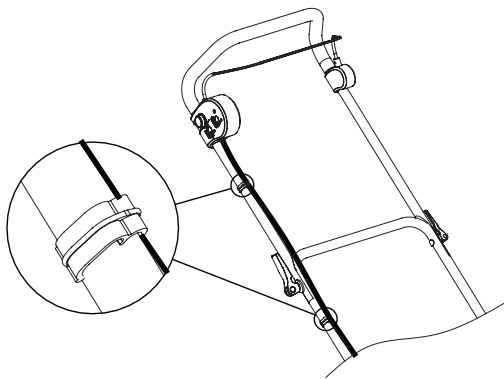

Attach the grass bag

Attach the grass collection bag to the frame by fixing the plastic hooks onto the side.

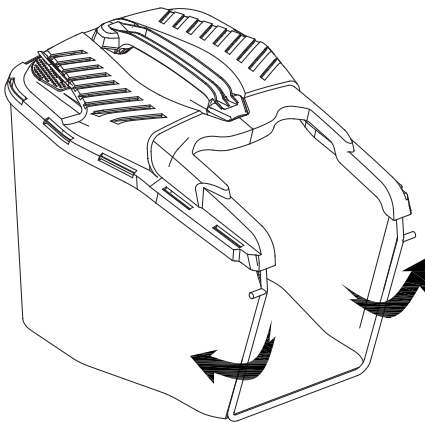

Lift the safety flap with one hand and hook in the grass collection bag. Release the safety flap to secure the grass collection bag in position.

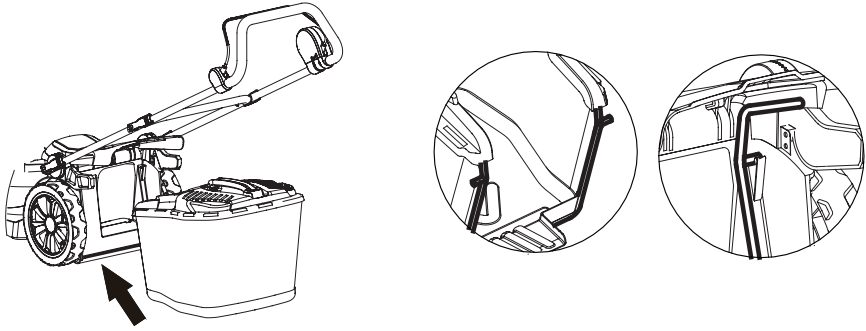

BEFORE OPERATION



WARNING: The charger and battery pack are specially designed to work together so do not attempt to use any other devices. Never insert or allow metallic objects into your charger or battery pack connections otherwise an electrical failure and hazard will occur.

NOTE: The battery pack comes partly charged. Charge the battery pack prior to first use, ideally at least 60 minutes.

- Always pull out the plug of the charger from the mains before removing or connecting the battery pack to the charger.
- Never charge the battery pack when the ambient temperature is below 5°C or above 45°C.
- Never recharge a battery pack again immediately after rapid charging. This could overcharge the battery pack, thus reducing the lifespan of the battery pack and charger.
- Rest the charger for at least 15 minutes between continuously charging sessions.

NOTE: Always fully charge the two batteries at the same time.

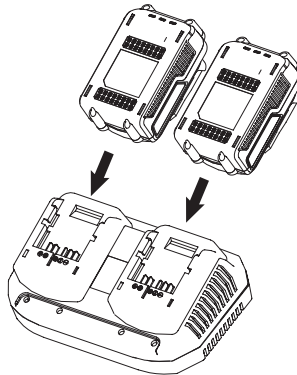

Checking battery capacity

Press the battery capacity level button to check the charging level of the battery pack. The status/remaining capacity will be shown on the battery charging level indication light.

3 Green LED on	Battery pack fully charged
2 Green LED on	Battery pack 65% charged
1 Green LED on	Battery pack 35% charged
No LED lit	Battery is dead and needs to be charged

Charge the battery pack before operating when it is at medium or low battery charging level.

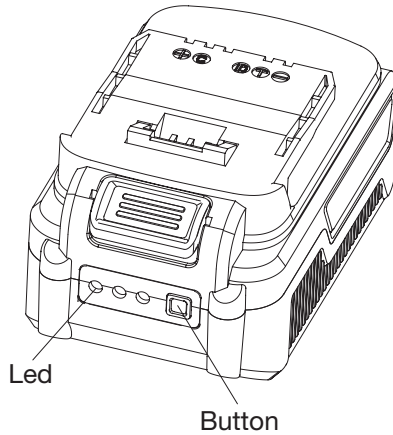

Charging procedure

- 1) Slide the battery pack into the charger base to make connections.
- 2) Connect the battery charger to the power supply. The indicator light will be green and flash to show that the charging has started.
- 3) When charging is completed, the light will be continuous lit, the pack is now fully charged, unplug the charger and remove the battery pack.

Charging light indicator

Red LED on, Green LED off	Charger ready
Red LED off, Green LED flashes	Battery pack charging
Red LED off, Green LED on	Battery pack fully charged
Red LED flashes, Green LED flashes	Battery pack defected
Red LED on, Green LED on	Battery pack too cold or hot

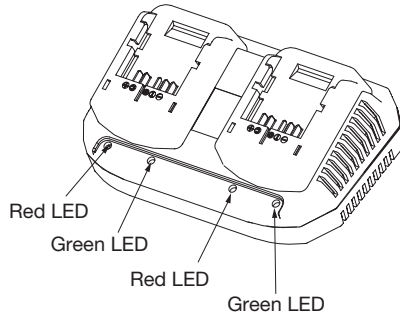

WARNING: When battery pack runs out after continuous use or exposure to direct sunlight or heat, allow time for the pack to cool down before re-charging to achieve the full capacity.

To obtain the best life from the battery

1. Never allow the battery to completely discharge before recharging. The battery pack should be placed on the charger whenever the battery pack is noticeably running down or the tool no longer performs a task it previously performed.
2. Avoid conducting short charges. Make sure that the battery is fully charged each time by allowing the charger to complete its full charging cycle.
3. Avoid allowing loose items like screws or nails etc. to be stored with battery packs as these or similar items can short battery packs and cause a fire or explosion
4. Always unplug the charger when not in use and store in a dry and secure place.
5. Avoid charging or storing your battery in temperatures below 5°C and above 45°C.
6. After use, allow the battery pack to cool down for approximately 30 minutes before attempting to recharge.

Removing and inserting the battery pack

Insert the battery pack

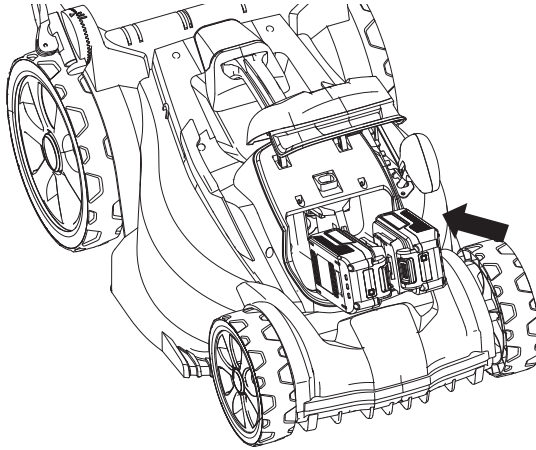

Open the battery pack compartment cover(8). Align the battery packs with its compartment of the tool. Push the battery packs with sufficient force into the compartment until you hear a click. This means the battery packs are locked in position, then close the battery pack compartment cover.

Removing the battery pack from the machine

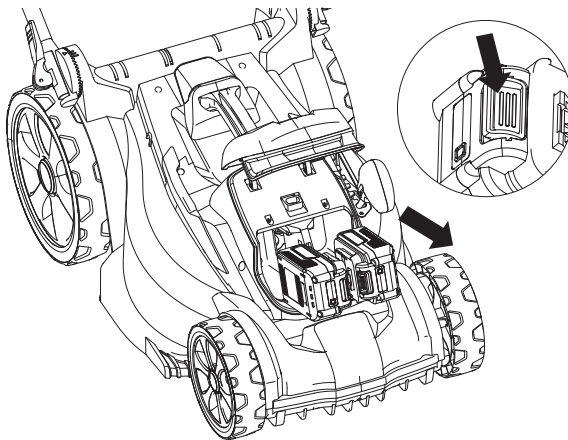

Open the battery pack compartment cover. Depress the battery pack release button, the battery pack will now be unlocked for removal.

When removing the battery pack, hold it firmly to avoid potential accidents.

Safety key

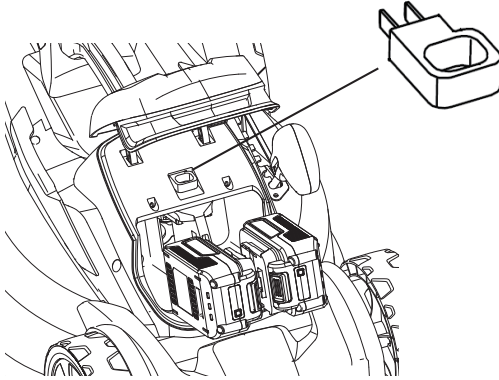

This lawn mower is fitted with a safety key, this prevents the accidental startup of your cordless lawn mower.

The safety key has been designed to totally disable the lawn mower when it is removed.

Setting the cutting height

Release switch lever and wait until the motor stops before adjusting cutting height. The blades continue to rotate after the machine is switched off, a rotating blade can cause injury.

Grip the cutting height adjustment lever and pull it outwards, then move it up or down a notch to increase or decrease the cutting height.

Locate the adjustment lever inwards to the notch again, until it engages in the desired level.

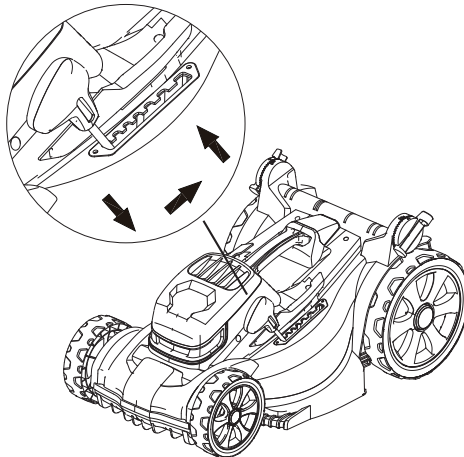

WARNING: Never operate the adjusting lever roughly.

Switching on and off

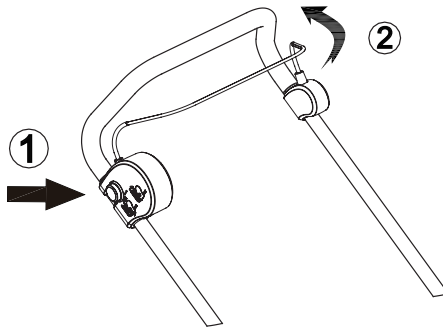

Switch on:

1. Press and hold the safety button on the side of the switch box with one hand.
2. Pull the switch lever towards the handle and hold it with the other hand.
3. Release the safety button.

Switch off:

Release the switch lever.

Operating the lawn mower



WARNING: Ensure the battery pack is disconnected from the mower before making any adjustment, cleaning and maintenance. When the motor has been switched off, the blade will continue to run for several seconds. Do not touch the underside of the mower until the cutter has come to a complete standstill!

Operation on a slope:

Slopes increase the risk of slip-and-fall accidents, which can result in severe injury. Always be sure of your footing on slopes. Operation on slopes requires extra caution. If you feel uneasy on a slope, do not mow it.

Do:

- Mow across the face of slopes, never mow up and down.
Exercise extreme caution when changing direction on slopes.
- Watch for holes, ruts, rocks, hidden objects or bumps which could cause you to slip or trip. Tall grass can hide obstacles.

Do not:

- Do not mow near drop-offs, ditches or embankments, you could lose your footing or balance.
- For safety reasons, do not use the mower on gradients exceeding 15°.
- Do not mow on wet grass. Unstable footing could cause you to slip.

Mower overload protection

To prevent overload conditions, do not try to cut too much grass at one time. Slow down your cutting pace or raise the cut height. Your mower has built-in overload circuit protection. When the mower is overloaded, the mower will stop. Switch the mower off and check to see if grass has collected beneath the deck and clear it if necessary, then restart the mower.

Battery high temperature protection

The battery pack will generate heat during operation. The heat dissipates slower in hot weather. If the battery temperature exceeds more than 70°C during operation, the protection circuit will immediately turn off the mower to protect the battery pack from damage. Release the switch lever, wait until the battery pack cools down and then restart the mower.

Function of full indicator

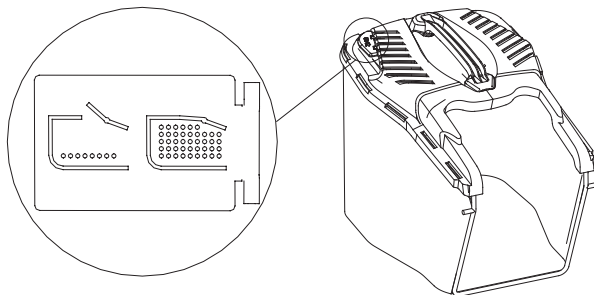

If the grass collection bag is empty or it is not filled with grass, the grass full indicator will be open.
If the grass collection bag is filled with grass, the grass full indicator will be closed.

Emptying the grass bag

As soon as the grass collection bag indicator closes whilst mowing, the grass bag is full and requires emptying.

NOTE: Before removing the grass bag, switch off the mower, disconnect the battery pack and wait until the blade has come to a complete stop.

To remove the grass bag, use one hand to lift up the safety flap and the other to hold on to the carry handle of the grass bag. The safety flap automatically falls down after removing the grass collection bag and closes off the rear chute opening. Empty the grass collection bag then refit to the mower.

NOTE: If any grass residue is caught in the discharge chute, clean it using a brush. Do not remove grass debris in the mower casing or on the blade by hand or with your feet. Instead, use suitable tools, such as a brush or broom. To ensure that the cut grass can be collected into the grass bag, the discharge opening and inside the mower casing must be cleared of any blockages.

CARE AND CLEANING

Maintenance and Storage



WARNING: Before performing any maintenance or cleaning work, always ensure that the battery pack/safety key has been removed. Wait until the blade has stopped completely and the machine has cooled down.

Cleaning

Cleaning the product

- Use a soft brush to remove accumulated dust and debris. Wear safety glasses to protect your eyes whilst cleaning.
- Wipe down the product enclosure with a slightly damp cloth.
Do not spray the unit with water. Water may destroy the switch unit and the electric motor.

Maintenance

NOTE: Always wear gardening gloves when handling or working near sharp blades.

1. Keep all nuts, bolts and screws tight to ensure that the machine is in a safe working condition.
2. Check the grass collection bag frequently for wear or deterioration.
3. Examine the machine and replace worn or damaged parts for safety.

Removing/installing the blade

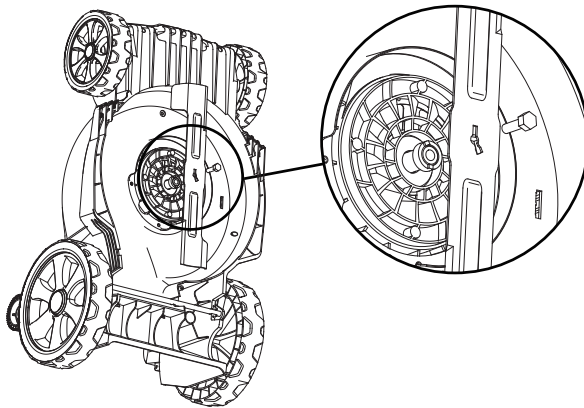

1. Use the correct size wrench to uninstall the blade bolt nut.
2. Wearing safety gloves, hold the blade still and turn the wrench anti-clockwise to remove the bolt.
3. Fit the replacement blade correctly with the markings facing up and align the pegs, refit the bolt and retighten securely to torque 20N.m.



WARNING: Replace or re-sharpen the mowing blade at the end of the mowing season. Always have the mowing blade re-sharpened or replaced by a recommended service centre. Unbalanced blades will cause the lawn mower to vibrate violently, which can increase the risk of accidents occurring.

Battery maintenance:

Use the following procedures to achieve the best battery life:

1. Protect the battery against moisture and water.
2. Store the battery only within temperature range of 5°C to 45°C. Do not leave the battery in direct sunlight for extended periods of time.
3. Clean the battery regularly with a soft, clean and dry brush.
4. If you do not use the product for a long time, remember to charge and discharge the battery pack once every 6 months.

Storage and transport

Storage

After cleaning the unit thoroughly, store the lawn mower in a dry room and allow the motor to cool down.

To reduce storage space, the lawn mower can be folded.

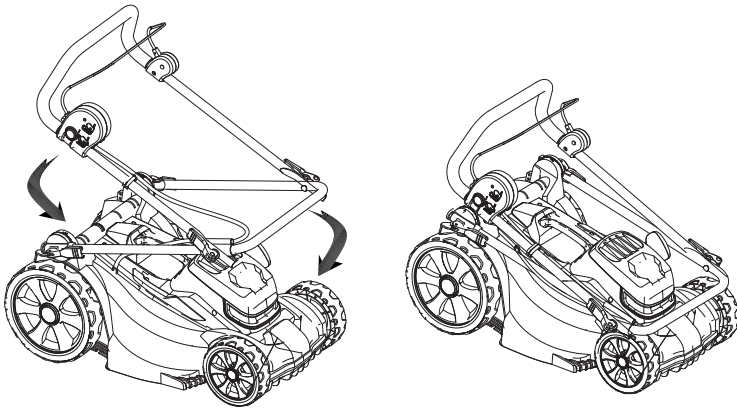

1. Loosen the handle quick release levers on the handles.
2. Fold the handles.
3. Stand up the mower and store.

NOTE: Remove the safety key and battery packs. Ensure cables are not trapped when folding/unfolding the handle. If stored vertically, make sure the mower is positioned in a corner so that the blade is facing inwards against a wall, and the machine is secure to prevent it falling over.

Transport

Use the original packaging to ship whenever possible.

Consumable parts

Part code	Part Name
1254469001	Blade

TROUBLE SHOOTING

Use this section to help you to try and solve any problems you may have:

Fault	Possible cause	Solution
Mower fails to start	Safety key is not inserted	Insert safety key
	Battery is not correctly inserted	Remove battery and reinsert
	High grass, rear of mower housing and blade are dragging in heavy grass, or cutting height too low.	Raise the cutting height
	The mower housing is clogged	Clean housing so blade can move freely
	Battery has no power	Check and recharge battery
Mower stops working/ loses power	Cutting height is incorrect	Adjust cutting height
	Cutting blade is worn or damaged	Replace with new blade from dealer service centre
	Battery performance decreasing	Check battery performance and charge if necessary
Grass collection bag is not filled sufficiently	Cutting height is too low	Adjust and increase cutting height
	The lawn/grass is wet	Allow lawn to dry
	Underside of mower deck is clogged	Clean underside of mower deck
	Cutting blade is worn or damaged	Replace by contacting customer service centre
Mower vibrating at higher speed	Cutting blade is unbalanced	Balance blade by grinding each cutting edge until equal
	Blade is loose/ incorrectly fitted	Tighten blade bolt
Mower cuts unevenly	The blade is damaged	Sharpen blade or replace
	Blade is assembled incorrectly	Re-assemble blade correctly

NOTE: IF YOU EXPERIENCE A PROBLEM WITH YOUR TOOL, PLEASE DO NOT ATTEMPT TO OPEN OR REPAIR THE TOOL YOURSELF. DOING SO MAY VOID THE WARRANTY AND COULD CAUSE DAMAGE OR PERSONAL INJURY. IF THE PROBLEM STILL PERSISTS, PLEASE CONTACT US BY REFERRING TO THE SERVICE & SUPPORT INFORMATION ON THE FOLLOWING PAGE.

DECLARATION OF CONFORMITY / PERFORMANCE



Product Code: 23984 (Y0J-SP03-4036ZA)

Product Description Hawksmoor: 2*18V 40cm Brushless Cordless Lawn Mower

1. Toolstation Limited, Express Park, Bristol Road, Bridgwater, Somerset TA6 4RN

This declaration of conformity is issued under the sole responsibility of Toolstation

2. Object of the declaration

The object of the declaration described above is in conformity with the relevant Community harmonization legislation:

Supply of Machinery (Safety) Regulations 2008

Electromagnetic Compatibility Regulations 2016

The Restriction of the Use of Certain Hazardous Substances in Electrical and Electronic Equipment Regulations 2012

Electrical Equipment (Safety) Regulations 2016

Noise Emission in the Environment by Equipment for use Outdoors Regulations 2001

Measured Sound Power Level: 94.62 dB(A)

Guaranteed Sound Power Level: 96 dB(A)

3. References to the relevant standards used (or references to the specifications in relation to which conformity is declared:

BS EN 55014-1; BS EN 55014-2; BS EN 60335-1; BS EN 60335-2-77; BS EN 61000-3-2;
BS EN 61000-3-3; BS EN 60335-2-29; BS EN 62233

4. Additional information:

Signed for and on behalf of Toolstation Limited

ENVIRONMENTAL INFORMATION



The symbol on the product or its packaging indicates that this product must not be disposed of with your other household waste. Instead, it is your responsibility to dispose of your waste equipment by handing it over to a designated collection point for the recycling of waste electrical and electronic equipment. The separate collection and recycling of your waste equipment at the time of disposal will help conserve natural resources and ensure that it is recycled in a manner that protects human health and the environment. For more information about where you can drop off your waste for recycling, please contact your local authority, or where you purchased your product.

GUARANTEE

Toolstation products deliver reliable service for normal, household use in domestic settings. All Toolstation products are individually tested before leaving the factory.

If you are a consumer and you experience a problem with your Toolstation product, which is found to be defective due to faulty materials or workmanship within the Guarantee Period, this Toolstation Guarantee will cover repair or - at the discretion of Toolstation - replacement with a functionally equivalent Toolstation product.

Your product is under guarantee for 2 years from the date of purchase or the date of delivery of the product, if later.

The guarantee is subject to the following provisions:

- The guarantee does not cover accidental damage, misuse, cabinet parts, knobs, or consumable items.
- The product must be correctly installed and operated in accordance with the instructions contained in this manual.
- It must be used solely for domestic purpose.
- The guarantee will be rendered invalid if the product is re-sold or has been damaged by inexpert repair.
- Specifications are subject to change without notice.
- The manufacturer disclaims any liability for the incidental or consequential damages.
- The guarantee is in addition to, and does not diminish your statutory or legal rights.

CUSTOMER SUPPORT

www.coreservice.co.uk

Call us +44 01904 947568

Email: support@coreservice.co.uk

Made in China