

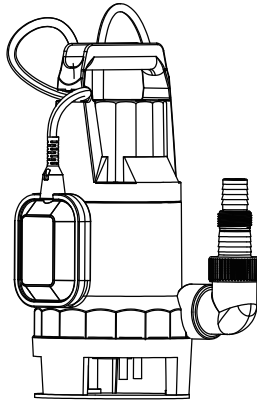

Original User's Instructions

Dirty Water Pump

SKU: 37119



WHAT'S IN THE BOX

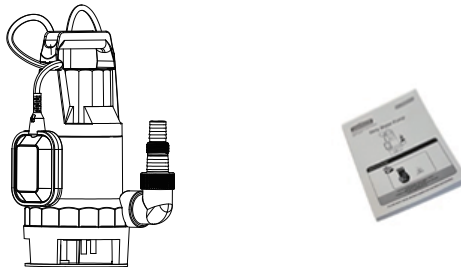

If you do not have all these items, please contact:
www.toolstation.com/contact
Telephone 0808 100 7211 Mobile friendly 0330 333 3303
Email info@toolstation.com

PLEASE KEEP THESE INSTRUCTIONS FOR FURTHER REFERENCE

SPECIFICATION

TECHNICAL DATA

Model	QSB-JH-750B
Rated Voltage	230V-50Hz
Rated Power Rate	750W
Plug	BS Plug
Power Cord Length(m)	10m
Power Cord Spec	H05RN-F3G1.0mm ²
Dimension(H x L x W-mm)	369x158x167
Net Weight(g)- approx.	5400
Max. lifting height	8m
Max. pump rate	216 L/min
Submergence depth-Max	7m
Max. grain size	ø35mm
Min water level	35mm
Water temperature-Max	35 °C
Float Switch	Y
Outlet nozzle size	1", G1", 1¼", G1½"
Protection class	Class I
IP rating	IPX8

EXPLANATIONS AND SYMBOLS, CAUTIONS AND WARNINGS



Disconnect the product from the power supply before assembly, cleaning, adjustments, maintenance, storage and transportation.



The product complies with the applicable European directives and an evaluation method of conformity for these directives was carried out.



A product placed on the United Kingdom market meets the UKCA Marking requirements



WEEE symbol. Waste electrical products should not be disposed of with household waste. Please recycle where facilities exist. Check with your Local Authority or local store for recycling advice.



Caution/Warning



Max. lifting height



Max. pump rate



Max grain size



Submergence depth Max

HEALTH AND SAFETY

- This product can be used by children aged from 8 years and above and persons with reduced physical, sensory or mental capabilities or lack of experience and knowledge if they have been given supervision or instruction concerning use of the product in a safe way and understand the hazards involved.
- Children should be supervised to ensure that they do not play with the product. Cleaning and user maintenance shall not be made by children without supervision.
- Prevent access of children with appropriate measures.
- If the power cord is damaged, it must be replaced by the manufacturer, its service agent or similarly qualified persons in order to avoid a safety hazard.
- All electrical sockets must be earthed.
- This product must be connected with a residual current device (RCD) having a rated residual operating current not exceeding 30mA.
- Do not use when people are in the water.
- Do not operate the pump without water.
- Make sure that no marine animals (e.g. fish) are extracted by the product.
- Have in mind that pollution of the liquid could occur due to leakage of lubricants.
- Protect the electrical connections and cords from heat, oil, sharp edges and moisture.
- Protect the product from frost and running dry.
- Avoid circulation of aggressive fluids of abrasive materials.
- Do not use the power cord or the float switch cable to transport or secure the product. Fix a rope to the handle for submerging, lifting or securing.
- Check and clean the outlet and the inlet of the pump when needed.
- Do not pump liquids with sand or other abrasive substances. It causes increased wear and reduces the pumps output.
- The product is designed for clear water with a diameter of suspended impurities not exceeded 35mm.
- The product should be used for pumping water temperature below 35°C, do not use the product for other liquids (hydrocarbons, oils, corrosive liquids, flammable liquids...).
- Never use the product in case of danger of frost.

- The product is not designed for continuous use. Please rest it for 10 min after each 1 hour running.
- Familiarize yourself with the operation, adjustments and functions. Internalize and follow the safety and operation instructions in order to avoid possible risks and hazards.
- Contact a qualified person or your dealer if you have questions after reading the instruction manual.
- Store the instruction manual so that it is accessible for all users. Also relay it when giving the product to others.
- Do not attempt to modify the product in any way. Only use attachments and accessories recommended by the manufacturer.
- Use the product only in accordance with this instruction manual. Misuse and incorrect handling will lead to hazards for people and property.
- Do not use the product if damage is visible.
- Check the power cord, plug, attached hoses and casing before each use. Faulty products must be repaired or properly disposed of.
- Disconnect the product from the power supply immediately if the cord or the product supply immediately if the cord or the product is damaged or if a breakdown occurs.
- Have the product repaired only by a qualified specialist. Improper repairs can lead to electric shocks or other accidents.
- Pull the plug rather than the power cord to disconnect the product from the power supply.
- Do not let the power cord hang over edges, do not squeeze or bend it.
- Use extension cords that correspond with the technical requirements of this product if using an extension cord is unavoidable.
- When operating products outdoors, use an extension cord suitable for outdoor use.

COMPONENT LIST

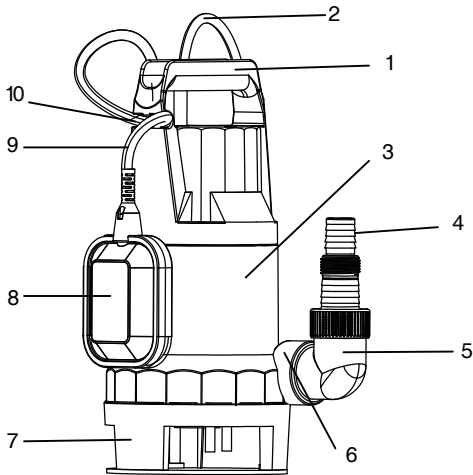

- 1. Handle
- 2. Power cord
- 3. Housing
- 4. Water connector
- 5. Elbow adaptor
- 6. Outlet
- 7. Base
 - a. Shim
 - b. Impeller
 - c. Nut
 - d. Main pump casing
 - e. O-ring
 - f. Screw(long)
 - g. Floor
 - h. Screw(short)
- 8. Float switch
- 9. Float switch cable
- 10. Clamp

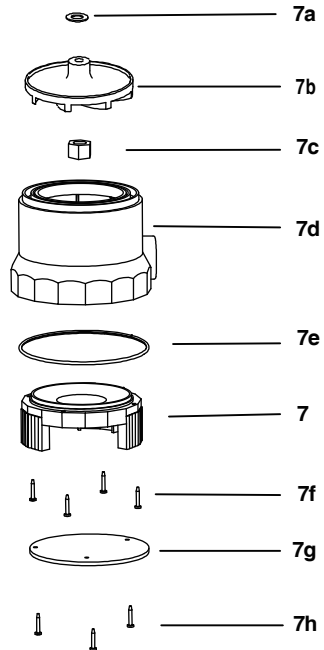

ASSEMBLY AND USE

Warning! The product must be fully assembled before operation! Do not use a product that is only partly assembled or installed with damaged parts. Follow the instructions step-by-step. Do not connect the product to power supply before it is completely installed.

Unpacking: Unpack all parts and lay them on a flat, stable surface. Remove all packaging materials and shipping devices, if applicable. Make sure the delivery contents are complete and free of damage. If you find that parts are missing or show damage do not use the product but contact your dealer. Using an incomplete or damaged product represents a hazard to people or property. Ensure that you have all the accessories and tools needed for assembly and operation.

Accessories: Only use accessories that fulfill the requirements of this product. Pay special attention to the diameter of hoses, pipes, adaptors and connectors. Ensure that connectors and adaptors are fitted with gaskets rings and fasten them only hand tight.

Hose/pipe system: Install pipes or hoses in such a way that they do not exert any mechanical pressure on the product. Secure pipe or hose in such a way as to prevent any oscillation, friction or weight impacting on the product. Lay the pipe or hose in as short and straight as possible. Avoid an excessive number of bends. Choose a reinforced delivery hose or pipe of the same or larger diameter as the outlet nozzle in order to reduce friction loss.

Assembly:

- Screw the connector (4) clockwise onto the adaptor if it's not already pre-assembled.
- Screw the adaptor (5) to the outlet nozzle (6). Tighten it properly.
- Attach a suitable hose or pipe to the connector (4) and secure it with fixation material.
- Fasten a rope (not provided) to the handle (1) and submerge the product carefully into the water reservoir.
- Lift the pump by a rope (not provided) from the water reservoir after use.

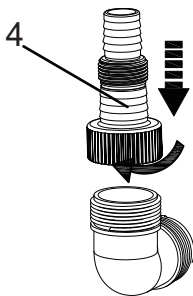

Fig.1

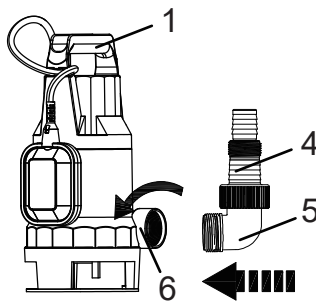

Fig.2

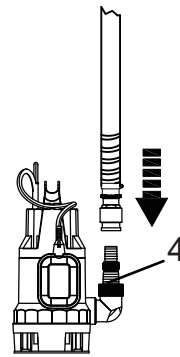

Fig.3

Warning! Do not lift the pump by power cord.

Note: We recommend guiding the power cord by means of clamps alongside fastening rope.

Connection to power supply:

Note: Ask a qualified electrician to ensure that the protective earth conductor and RCD correspond with the local safety regulations and work faultlessly before connecting the product to the power supply.

Warning! You must test the RCD device before every use. Do Not use this product when there is a failure in the above mentioned test.

Intended use: This submersible pump is designated and intended for the circulation of water with maximum temperature of 35°C. With suitable accessories the product can be used for draining when flooding occurs in rooms and also for pumping over to or pumping out of water containers, to remove water from wells and shafts, for draining boats and yachts. The product can be fully submerged (watertight encapsulation) and lowered to a water depth 7 meters. The product is not suitable for long term circulator use (e.g. in a pond, swimming pool, aquarium). The product is used for water with PH between 6.5 and 8.5, and may not be used for other fluids, especially corrosive, flammable or explosive substances and other chemical products. For safety reasons it is essential to read the entire instruction manual before first operation and to observe all the instruction therein. This product is intended for private use only, not for any commercial trade use. It must not be used for any purposes other than those described.

Float switch: This product works with automatic interval operation. The float switch (8) swims on the surface of the water or alternatively under water. The product switches on or off according to position of the float switch (8). In this way, you can automatically control the water level e.g. in wells or containers.

Note: The float switch contains a ball that activates a switch. The product works only if the float switch is above position A, position B corresponds to the switch off level of the pump.

The product is started at a certain water level by the float switch (8) (switch on level). The product continues pumping until the water level is lowered to a particular height and then the float switch turns the product off (switch off level). Adjust the height of the relative switch on and off levels within certain parameters by lengthening or shortening the free cable length of the float switch cable (9). Fix the float switch cable (9) to the clip (10).

Always make sure that the float switch (8) is free and unblocked when in the water to prevent the dry running.

Note: Make sure the cable length is not less than 45mm between float switch and clip.

Note: Before first use you should briefly familiarize yourself with the automatic controls of the float switch. Move the float switch up and down with your hand to simulate switching on and off. Alter the free cable length until you have found a suitable extend to your purpose. Check out how the free cable length influences the switch on and off level (and ultimately the water level).

Note: Make sure the base can freely draw water and is free of mud, when lowering the pump to the ground of the water source.

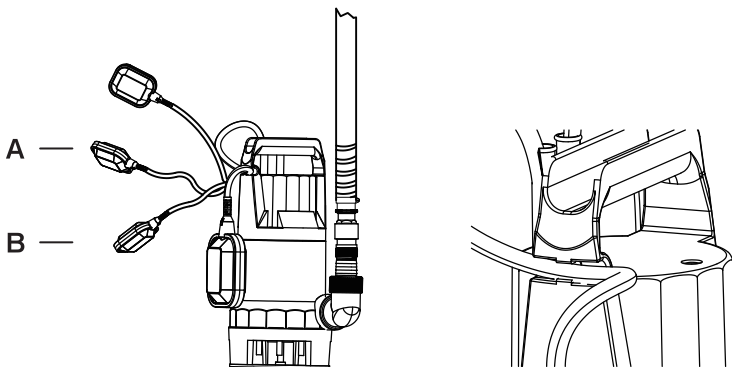

Thermal protection: The product is equipped with a thermal cut-out. In the event that the motor becomes overheated due to an over-load operation such as clogged intake or low or no water, the thermal cut-out automatically switches the product off. After a cooling period the product automatically switches on again. Disconnect the product from the power supply in case the thermal protection is activated.

Inspect the product for possible damage, wear or foreign objects that e.g. block impeller.

Eliminate the cause prior to re-starting the product (see Troubleshooting).

Note: Should the thermal protection continuously be activated even after following the steps under "Troubleshooting" do not longer use the product. Have it checked and repaired by a qualified technician.

Automatic air bleed valve: The automatic air bleed valve releases any air pockets in the pump body. During this process, air escapes through the ventilation bore on the pump and air bubbles appear underwater. It may take several seconds when the pump is immersed for the first time.

General operation:

- Check the product, its power cord and plug, the float switch cable as well as accessories for damage before each use. Do not use the product if it is damaged or shows wear. The product must be fully immersed into the water. Otherwise the product cannot prime and the maximum constant flow will not be achieved. The product could be damaged! To have an automatic start the pump must be submerged in a water reservoir with a minimum water level of 145mm. If the water level is any less, the pump may not suck properly and there is a risk of dry running.
- Double check that the accessories are properly fixed. Connect the plug with a suitable socket to switch the product on.
- Connect the product to the power supply. The product is switched on automatically at a certain water level (switch on level) and switches off as soon as the water level drops down to a definite water height (switch off level). We recommend disconnecting the product from the power supply when you are not able to perform inspection over a longer period of time. This product can be used to suck up water with lower height (water level higher than 70mm) but must be manually operated the float.
- If the product does not pump after several attempts, the water level is too low to seal the system. Lower the float switch to stop the product.

After use: Disconnect the product from the power supply and let it down. Check, clean and store the product and its accessories as described below.

CARE AND CLEANING

- Always disconnect the product from power supply and let it cool down before performing inspection, maintenance and cleaning work!
- Keep the product clean. Remove debris from it after each use and before storage.
- Store the product and its accessories in a dark, dry, frost-free, well-ventilated place. Always store the product in a place that is inaccessible to children. The ideal storage temperature is between 10°C and 30°C.
- Regular and proper cleaning will help ensure safe use and prolong the life of the product.
- Inspect the product before each use for worn and damaged parts. Do not operate it if you find broken and worn parts.
- Only perform repairs and maintenance work according to these instructions! All further works must be performed by a qualified specialist!
- Clean the product with a damp cloth and pH-neutral soap. Use a brush for areas that are hard to reach.
- Remove stubborn dirt with high pressure air (max.3 bar).
- Do not use chemicals, alkaline, abrasive or other aggressive detergents or disinfections to clean this product as they might be harmful to its surfaces.
- Check for worn or damaged parts. Replace worn parts as necessary or contact an authorized service centre for repair before using the product again.
- Regularly check for obvious defects such as loose, dislodged or damaged hoses, loose fixings and worn or damaged components.
- Before and after each use, check the product and attachments (such as hoses, clip etc.) for wear and damage. If required, exchange them for new ones as described in this instruction manual. Observe the technical requirements.
- If excessive deposits collect in the base, dismantle the base and base plate of the product and clean the components.

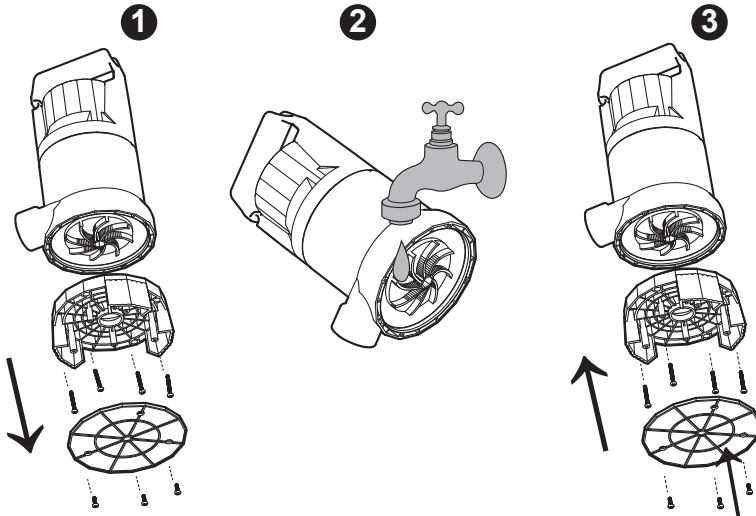

Tools might required



TROUBLE SHOOTING

Use this section to help you to try and solve any problems you may have.

Only perform the steps described within these instructions! All further inspection, maintenance and repair work must be performed by an authorized service centre or a similarly qualified technician if you cannot solve the problem yourself.

PROBLEM	POSSIBLE CAUSES	REMEDIES
Product does not start	<ul style="list-style-type: none"> Power supply not connected Float switch does not switch on 	<ul style="list-style-type: none"> Check power supply connection Raise position of the float switch
Insufficient flow/no flow	<ul style="list-style-type: none"> Reduced pumping capacity by dirty and abrasive water Hose or pipe is clogged Hose or pipe system is damaged 	<ul style="list-style-type: none"> Clean product or have worn-out parts replaced Unclog hose or pipe Replace it
Product does not switch off	Float switch cannot move down	Ensure the floating switch can move freely
Product switches off after short operating period	<ul style="list-style-type: none"> Thermal cut-out stops product due to blockage Thermal cut-out stops product due to high water temperature Impeller is caught by foreign substance 	<ul style="list-style-type: none"> Remove blockage and clean the product Make sure that the water temperature of max.35°C is not exceeded. Remove blockage

DECLARATION OF CONFORMITY / PERFORMANCE



Product Code 37119(QSB-JH-750B)
Product Description Dirty water pump 750W

1. Toolstation Limited, Express Park, Bristol Road, Bridgwater, Somerset TA6 4RN

This declaration of conformity is issued under the sole responsibility of Toolstation

2. Object of the declaration

The object of the declaration described above is in conformity with the relevant Community harmonization legislation:

- Supply of Machinery (Safety) Regulations 2008 (MD 2006/42/EC)
- Electromagnetic Compatibility Regulations 2016(EMC 2014/30/EU)
- The Restriction of the Use of Certain Hazardous Substances in Electrical and Electronic Equipment Regulations 2012(RoHS 2011/65/EU&2015/863/EU)
- REACH (EC) No 1907/2006

3. References to the relevant standards used (or references to the specifications in relation to which conformity is declared):

- BS EN 60335-1
- BS EN 60335-2-41
- BS EN 62233
- BS EN 55014-1
- BS EN 55014-2
- BS EN 61000-3-2
- BS EN 61000-3-3

4. Additional information:

Signed for and on behalf of Toolstation Limited

ENVIRONMENTAL INFORMATION



When your heater comes to the end of its life or you choose to update or upgrade it by replacing it, please do not dispose of it with your normal household waste. Please recycle where facilities exist. When you need to dispose of this heater, check with your retailer or local authority for suitable options. Regulations encourage the recycling of Waste from Electrical and Electronic Equipment (DIRECTIVE 2012/19/EU OF THE EUROPEAN PARLIAMENT AND OF THE COUNCIL of 4 July 2012 on waste electrical and electronic equipment (WEEE)).

GUARANTEE

Toolstation products deliver reliable service for normal, household use in domestic settings. All Toolstation products are individually tested before leaving the factory.

If you are a consumer and you experience a problem with your Toolstation product, which is found to be defective due to faulty materials or workmanship within the Guarantee Period, this Toolstation Guarantee will cover repair or - at the discretion of Toolstation – replacement with a functionally equivalent Toolstation product.

Your product is under guarantee for 2 years from the date of purchase or the date of delivery of the product, if later.

The guarantee is subject to the following provisions:

- The guarantee does not cover accidental damage, misuse, cabinet parts, knobs, or consumable items.
- The product must be correctly installed and operated in accordance with the instructions contained in this manual.
- It must be used solely for domestic purpose.
- The guarantee will be rendered invalid if the product is re-sold or has been damaged by inexpert repair.
- Specifications are subject to change without notice.
- The manufacturer disclaims any liability for the incidental or consequential damages.
- The guarantee is in addition to, and does not diminish your statutory or legal rights.

CUSTOMER SUPPORT

www.toolstation.com/contact

Call us 0808 100 7211

Mobile friendly 0330 333 3303

Email: info@toolstation.com

Made in China

