

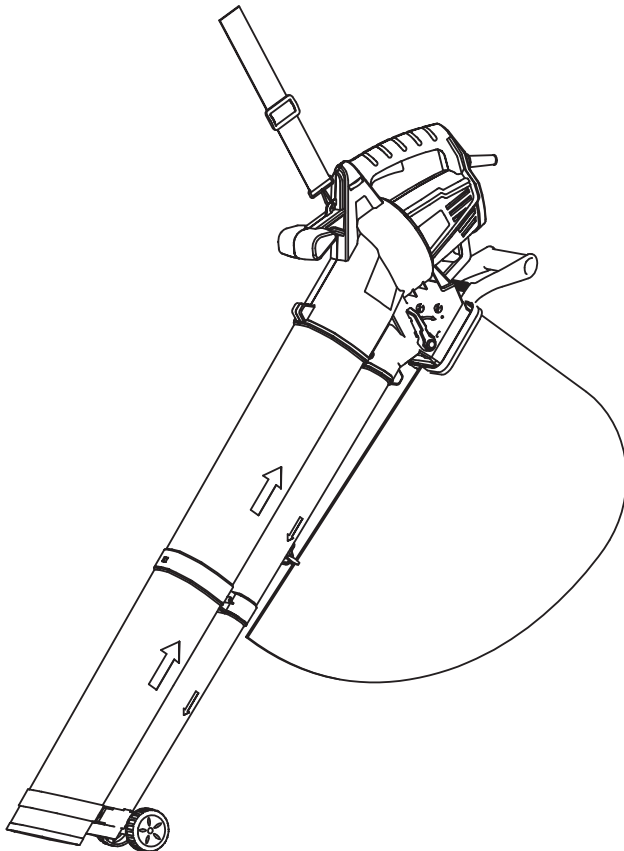

Original User's Instructions

2600W Electric Blower Vacuum

SKU: 18783



READ BEFORE USE

PLEASE KEEP THESE INSTRUCTIONS FOR FURTHER REFERENCE

CONTENT

• WHAT'S IN THE BOX -----	3
• SPECIFICATIONS -----	4
• EXPLANATIONS AND SYMBOLS, CAUTIONS AND WARNINGS -----	5
• IMPORTANT SAFETY WARNINGS -----	7
• PRODUCT DESCRIPTION AND IDENTIFICATIONS -----	14
• ASSEMBLY AND OPERATING INSTRUCTIONS -----	15
• CARE AND CLEANING -----	18
• TROUBLE SHOOTING -----	19
• DECLARATION OF CONFORMITY / PERFORMANCE -----	20
• ENVIRONMENTAL INFORMATION -----	21
• GUARANTEE -----	22
• CUSTOMER SUPPORT -----	22

WHAT'S IN THE BOX

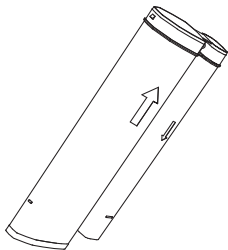

Lower tube x 1

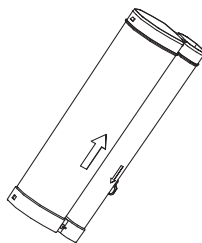

Upper tube x 1

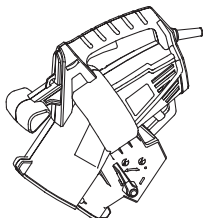

Housing x 1

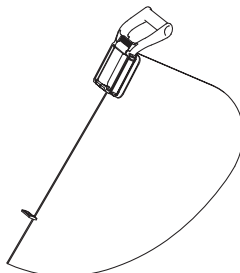

Collection bag
and bracket x 1

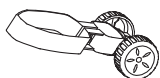

Bracket wheel x 1



Screw x 4

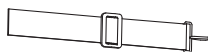

Belt x 1

If you do not have all these items, please contact:

www.coreservice.co.uk

Hotline: +44 01904 947568

Email support@coreservice.co.uk

TOOLS REQUIRED



SPECIFICATION

Technical Data	
Model No.	DT2260F
Voltage / Frequency	220V-240V~ , 50Hz
Input Power	2600W
No Load Speed	9000~15,000/min
Air Speed	160-270km/h
Max. air volume	13.2m ³ /min
Collection bag	35L
Mulching rate	10 : 1
Net Weight	3.33kg
Measured Sound Pressure Level	90.2dB(A) K=3dB
Measures Sound Power Level	102.4dB(A) K=3dB
- Guaranteed sound power level	105dB(A)
	4.27m/s ² K=1.5m/s ²
Cable	PVC 2 x 0.75mm ² , 10m, BS plug

The sound values have been determined according to noise noise directive 2000/14/EC & 2005/88/EC

The sound intensity level for the operator may exceed 80 dB(A) and ear protection measures are necessary.

The declared vibration value has been measured in accordance with a standard test method (according to EN 786) and may be used for comparing one product with another. The declared vibration value may also be used in a preliminary assessment of exposure.

The declared vibration value has been measured in accordance with a standard test method (according to EN 786) and may be used for comparing one product with another. The declared vibration value may also be used in a preliminary assessment of exposure.



WARNING!

Depending on the actual use of the product the vibration values can differ from the declared total! Adopt proper measures to protect yourself against vibration exposures! Take the whole work process including times the product is running under no load or switched off into consideration!

Proper measures include among others regular maintenance and care of the product and cutting attachments, keeping hands warm, periodical breaks and proper planning of work processes!

EXPLANATIONS AND SYMBOLS, CAUTIONS AND WARNINGS



Caution / Warning.



Read the instruction manual.



Wear hearing protection.



Wear eye protection.



Wear dust protection.



Wear protective gloves.



Wear protective, slip-resistant footwear.



Switch the product off and disconnect it from the power supply before assembly, cleaning, adjustments, maintenance, storage and transportation.



Remove plug from the mains immediately if the cable is damaged or cut.



Do not expose the product to rain or wet conditions.



Warning: The fan is still rotating when open or close the cover, be careful, specially the inlet cover.



Be aware of people around you and do not direct towards them.



Objects thrown by the product could hit the user or other bystanders. Always ensure that other people and pets remain at a safe distance from the product when it is in operation. In general, children must not come near the area where the product is.



Guaranteed sound power level value in 105dB.



This product is of protection class II. That means it is equipped with enhanced or double insulation.



The product complies with the applicable European directives and an evaluation method of conformity for these directives was done.



UK Conformity Assessed



WEEE symbol. Waste electrical products should not be disposed of with household waste. Please recycle where facilities exist. Check with your Local Authority or local store for recycling advice.

IMPORTANT SAFETY WARNINGS

IMPORTANT READ CAREFULLY BEFORE USE KEEP FOR YOUR REFERENCE



WARNING! When using the product the safety rules must be followed. For your own safety and that of bystanders, please read these instructions before operating the product. Please keep the instructions safe for later use.

Training

- Read the instructions carefully. Be familiar with the controls and the proper use of the product.
- Never allow people unfamiliar with these instructions or children to use the product. Local regulations can restrict the age of the operator.
- Keep in mind that the operator or user is responsible for accidents or hazards occurring to other people or their property.
- This product is not intended for use by persons (including children) with reduced physical, sensory or mental capabilities, or lack of experience and knowledge, unless they have been given supervision or instruction concerning use of the product by a person responsible for their safety.
- Children should be supervised to ensure that they do not play with the product.

Preparation

- The personal protective equipment protects your own health and the health of others and ensures the smooth operation of the device.
- Wear suitable work clothing, such as sturdy shoes with nonslip

soles, long, robust trousers, gloves, safety goggles and ear protection. Wear these at all times while operating the machine. Never use the device barefooted or wearing open sandals. Wear respiratory protection to protect against dust.

- Do not wear clothing or jewellery that could be sucked into the air intake. Wear protective headwear to contain long hair. Keep long hair away from the suction apertures.
- Pay attention to people, especially children, pets, open windows, etc. The blown material can be thrown in their direction.
- Stop working if they are in close proximity. Keep a safety distance of 5 m around you.
- Be familiar with your surroundings and pay attention to potential dangers that may be overlooked when working.
- Carefully inspect the surface to be cleaned and remove all wires, stones, cans and other foreign bodies.
- Use a rake or broom to remove foreign bodies before beginning the blowing/suction process.
- Use both parts of the blowpipe so that the airflow can work close to the ground.
- In very dry conditions, lightly moisten the surface or use a sprayer to reduce the build-up of dust.
- Do not work with a damaged or incomplete device or one which has been converted without the permission of the manufacturer.
- Before use, check the safety status of the device, in particular the mains cable and the switch.
- Only use the device when fully assembled.
- Only use the device in suction mode if the collection bag is attached. Check the collection bag regularly for wear or damage.
- Never operate the device with defective protection equipment or faulty protection covers or without any protection equipment.
- Please be aware that the operator or user is responsible for accidents or injuries to other people or their property.
- Avoid wearing loose clothing, clothing with hanging laces or ties.
- Operate the machine in a recommended position and only when

standing on a solid, flat surface.

- Do not operate the machine on a paved surface or a gravel surface where the ejected material could cause injury.
- Always perform a visual inspection prior to use to make sure that the shredding machine(including its bolts) and other fastening equipment are secured, and that the housing is undamaged and the protective equipment and shields are present.
- Replace worn or damaged components in sets to ensure balance. Replace damaged or illegible markings.

Operation

- Do not switch on the device if it is held upside down or is not in operating position. Avoid starting the device unintentionally.
- Make sure that the device is switched off before you pick it up or carry it. Having your finger on the switch off the device while carrying ,it can cause accidents.
- Never point the device at others,and in particular, do not point the air jet at the eyes and ears during operation.
- Always ensure secure positioning, particularly on slopes,when working. Always hold the device tightly with both hands and only work with a correctly adjusted carrying strap.Do not stretch too far and do not lose your balance.
- Keep fingers and feet away from the suction pipe aperture and impeller. There is a risk of injury.
- If you are tired or lacking in concentration or have consumed alcohol or tablets, do not work with the device. Always have a break on time.
- Work using common sense.
- Move slowly, do not run.
- Prolonged use of the device can lead to blood circulation disorders in the hands caused by vibration. You can however extend your machine use time by wearing appropriate gloves or by taking regular breaks.

- Avoid operating the machine in poor weather conditions, especially when there is a lightning hazard. Only work in daylight or where there is good artificial illumination.
- Do not vacuum burning, glowing or smoking materials (e.g. cigarettes, embers etc.), vapours or highly flammable, toxic or explosive substances.
- Stop the machine and disconnect the plug from device .Ensure the moving parts are at a full standstill.
 - when you are not using the device or when you are transporting or leaving it unattended;
 - before removing any obstruction or blocked channels,
 - before checking, cleaning or carrying out other work on the machine.
 - after contact with foreign bodies or if abnormal vibration occurs.
- Do not use the device in a closed or poorly ventilated area.
- Do not use the device near flammable liquids or gases. There is a risk of fire or explosion if this advice is not heeded.
- In the case of an accident or malfunction during operation, the device must be switched off immediately and disconnect the plug from power source. Read the “Troubleshooting” section to correct any malfunctions.
- Ensure that the in-feed is empty prior to starting the machine.
- Keep your face and body away from the in-feed aperture.
- Do not allow hands or other body parts or clothing to enter the in-feed or discharge chute, or to be in the vicinity of moving parts.
- Ensure you are standing securely and do not lose your balance. Avoid an abnormal work posture. When material is being taken in by the machine, never stand on a higher level than the base of the machine.
- Do not stand within the ejection zone while operating the machine.
- Take extreme care when feeding material into the machine to

ensure no metallic objects, stones, bottles, canisters or other foreign objects are taken in.

- Do not allow processed material to accumulate in the ejection zone since this can prevent proper ejection and cause the material to be brought back into the machine via the in-feed aperture.
- If the machine becomes clogged, turn off the power source and disconnect the machine from the mains supply or remove the batteries before freeing any refuse.
- Never operate the machine with defective protective equipment, or shields, or without safety equipment, e.g. without the collection bag being connected.
- Keep the power source free of refuse or other accumulated material to prevent it from becoming damaged and to avoid a potential fire.
- If the cutting mechanism comes into contact with a foreign object or the machine starts to emit unusual noises or vibrate, immediately turn off the power source and wait for the machine to come to a standstill. Disconnect the machine from the mains supply or remove the batteries and perform the following steps before re-starting and operating the machine:
 - investigate for damage;
 - replace or repair damaged parts;
 - check for loose parts and tighten as necessary.
- Ensure that you do not touch any of the dangerous moving parts before you have unplugged the machine from the mains supply or removed the batteries from the machine, and that the dangerous moving parts have come to a complete standstill.
- In the case of an accident or malfunction during operation, the device must be switched off immediately. Injuries must be properly treated or medical assistance sought. Read the “Troubleshooting” section to correct any malfunctions.

Maintenance and storage

- Regularly check the functionality and integrity of the device to avoid danger to the operator.
- Replace worn or damaged parts in the interests of safety. Only use original replacement parts and accessories.
- Do not try to repair the device yourself, unless you have professional training. All work not mentioned in these instructions may only be performed by authorised service representatives commissioned by us.
- Store the device in a dry place and out of reach of children.
- Treat your device with care. Clean the ventilation slits regularly and follow the maintenance instructions.
- Keep all inlets for the cooling air free of debris.
- Do not use the device if the switch cannot be turned on and off. Damaged switches must be replaced at a customer service workshop. Do not overload your device. Only work within the power range indicated. Do not use low-performance machines for heavy work. Do not use the device for purposes for which it is not intended.
- If you stop the machine for maintenance, inspection, storage or to change accessories, switch off the power source, disconnect the machine from the mains supply or remove the batteries and ensure that all moving parts have come to standstill. Allow the machine to cool down before the inspection, changing accessories, etc.,
- Maintain the machine with care and keep it clean.
- Always allow the machine to cool down before storage.
- Be aware that the shredding machine can always still move even if the power source is switched off by the locking function of the protective equipment. Be aware of this when maintaining the shredding machine.
- Never try to circumvent the locking function of the protective equipment.

Emergency

Familiarise yourself with the use of this product by means of this instruction manual. Memorise the safety directions and follow them to the letter. This will help to prevent risks and hazards.

- a. **Always be alert when using this product, so that you can recognise and handle risks early.** Fast intervention can prevent serious injury and damage to property.
- b. **Switch off and disconnect from the power supply if there are malfunctions.** Have the product checked by a qualified professional and repaired, if necessary, before you operate it again.

Residual risks

Even if you are operating this product in accordance with all the safety requirements, potential risks of injury and damage remain. The following dangers can arise in connection with the structure and design of this product:

- a. Health defects resulting from vibration emission if the product is being used over long periods of time or not adequately managed and properly maintained.
- b. Injuries and damage to property due to broken attachments or the sudden impact of hidden objects during use.
- c. Danger of injury and property damage caused by flying objects.
- d. Injuries and damage to property to due to thrown and fallen objects.



WARNING! This product produces an electromagnetic field during operation! This field may under some circumstances interfere with active or passive medical implants! To reduce the risk of serious or fatal injury, we recommend persons with medical implants to consult their doctor and the medical implant manufacturer before operating this product!

PRODUCT DESCRIPTION AND IDENTIFICATIONS

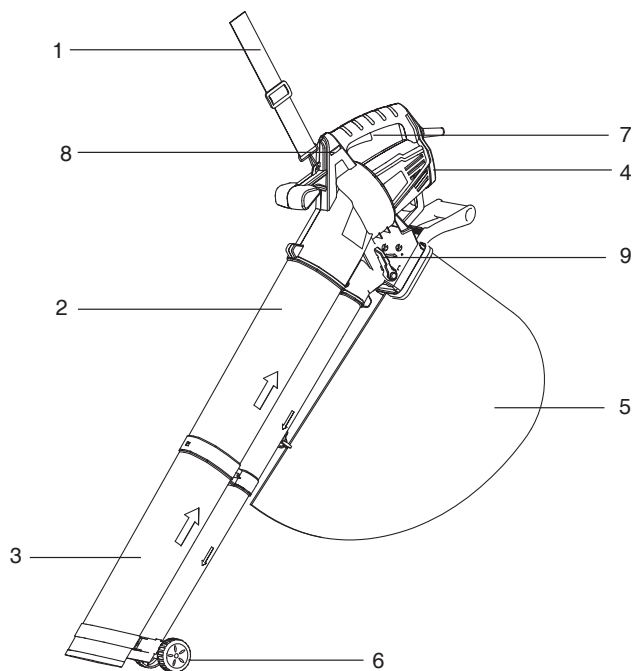

- 1 Belt
- 2 Upper tube
- 3 Lower tube
- 4 Housing
- 5 Collection bag
- 6 Bracket wheel
- 7 Switch
- 8 Speed adjustable switch
- 9 Function selector lever

Not all the accessories illustrated or described are included in standard delivery.

ASSEMBLY AND OPERATING INSTRUCTIONS



Warning!

The Vacuum-Blower must not be used or switched on until it has been fully assembled.

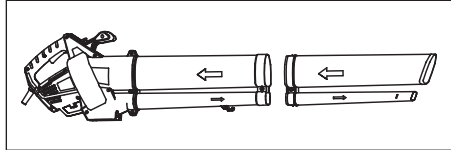

Fig.2

Assembly (Fig.3 Fig.4 and Fig.5)

1. Pull out the two suction/blower tubes, one Vacuum-blower body, 1set wheel + bracket, four screws that in the manual bag from package, the user need to assemble the tube 2-1 Insert into tube 2-2 forcibly, fasten the screw (ST4 x 50) until they connect well. Please refer to Fig. 3. And then put the whole tube into the machine body and secure fixed by other two provided screw (ST4 x 16), refer to Fig. 4.

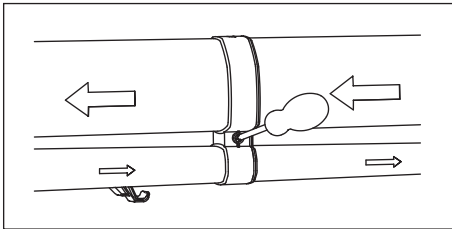

Fig.3

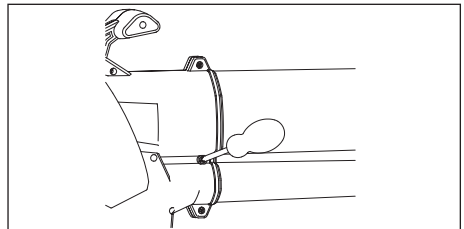

Fig.4

2. Refer to Figure 5, holding bracket of wheels and install it in the proper position of 2-1 tube, and then tighten the ST4 x16 screw.

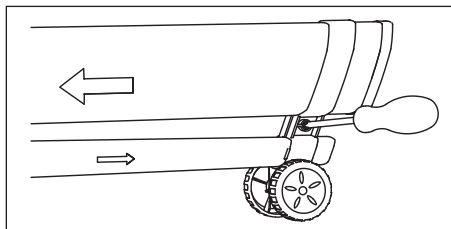

Fig.5



WARNING:

IF ANY PART IS MISSING OR DAMAGED, DO NOT PLUG IN THE MACHINE UNTIL YOU HAVE REPLACED THE MISSING OR DAMAGED PART.

Fitting the debris collection bag (Fig.6 and Fig. 7)

Before fitting the debris collection bag ensure that the Vacuum/Blow selector lever operates smoothly and that it is not obstructed by debris from the previous use.

Hold the hook on collection bag to tube (refer to Fig. 6), and then locate the bracket of debris collection bag to insert the curve tube (Refer to Fig. 7).

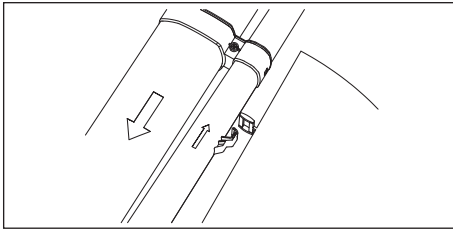

Fig.6

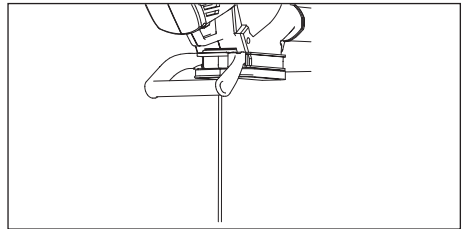

Fig.7

• Starting the Vacuum-Blower

Before start the Vacuum-Blower, ensure that the two intermediate suction/blower tubes together with the machine body are fitted correctly.

• Using the Vacuum-Blower

Do not attempt to pick up wet debris, allow fallen leaves etc, to dry out before using the Vacuum Blower. The Vacuum-Blower can be used to blow debris from patios, paths, driveways, lawns, bushes and borders. It will also pick up leaves, paper, small twigs and wood chippings. When the using the Vacuum-Blower in Vacuum mode, the debris is sucked up through the suction tube before being ejected into the debris collection bag, as the debris passes through the suction fan it is partially shredded. The shredded organic debris is ideal to use as mulch around plants.



Warning! Any hard objects, such as stones, tin cans glass etc, will damage the suction fan.

Important

Do not use the Vacuum-Blower to suck up water or very wet debris.

Never operate the Vacuum-Blower without the debris collection bag fitted.

Operating the Vacuum-Blower



WARNING: IF THE CORD HAS BEEN DAMAGED, HAVE IT REPLACED BEFORE USING THE BLOWER.

Blower mode

Inspect the area to be worked before starting. Remove any objects or debris that could be thrown, jammed or become entangled in the Vacuum-Blower.

Select the blow function using the selector lever on the side of the machine (Fig.8) and switch on. With the Vacuum- Blower resting on its wheels, move the Vacuum-Blower forwards directing the nozzle at the debris to be cleared.

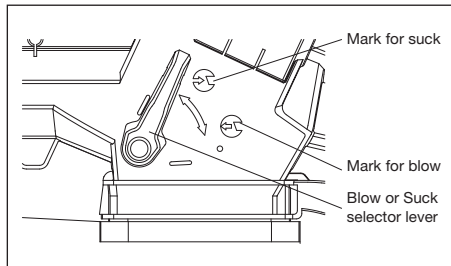

Fig.8

Alternatively hold nozzle just above the ground and swing the machine from side to side, moving forwards and directing the nozzle at the debris to be cleared. Blow the debris into a convenient heap then use the vacuum function to collect the debris.

Vacuum mode

Inspect the area to be worked before starting. Remove any objects or debris that could be thrown, jammed or become entangled in the Vacuum-Blower. Select the vacuum function using the selector lever on the side of the machine (Fig. 8) and switch on. With the Vacuum-Blower resting on its wheels move the Vacuum-Blower forwards directing the nozzle at the debris to be collected. Alternatively with the Vacuum-Blower held just above the ground swing the machine from side to side, moving forwards and directing the nozzle at the debris to be collected. Do not force the nozzle into the debris as this will block the suction tube and reduce the efficiency of the machine.

Organic materials such as leaves contain a large amount of water that can cause them to stick to the inside of the suction tube. To reduce sticking the material should be left for a few days to dry out.



WARNING: WHEN DISCHARGE THE LEAVES WHICH HAVE BEEN SHREDED, DISCONNECT THE PLUG TO THE MAIN POWER SUPPLY AND PUT THE SWITCH TO OFF POSITION.

CARE AND CLEANING

Warning! Before carrying out any checks or maintenance operations, disconnect the plug from the electric power supply.

Check your machine regularly before starting the work. Make sure that all nuts, bolts and screws are tight and that the guards are fitted correctly.

All damaged and worn parts should be replaced in order to maintain the Vacuum-Blower in a safe working condition.

Never leave material in the Vacuum-Blower or the debris collection bag. This could be dangerous when starting the Vacuum-Blower.

After use the Vacuum-Blower should be thoroughly cleaned.

Ensure that the Vacuum-Blower is switched off and disconnected from the mains supply. Remove and empty the debris collection bag. Ensure that the Vacuum / Blow selector lever operates smoothly and that it is not obstructed by debris. Brush any loose debris from around the fan and inside the suction/blower tube.

Always keep the ventilation slots in motor housing clean

Never clean or spray a machine with water. Clean the motor housing only with a moist cloth and never use detergents or solvents! These could ruin the plastic parts of the machine. Finally, dry the motor housing carefully.

Store the appliance in a dry place, out reach of children.

if the replacement of the supply cord is necessary, this has to be done by the manufacturer or his agent in order to avoid a safety hazard.

WARNING: FOR YOUR OWN SAFETY THIS BLOWER&VAC. IS DOUBLE INSULATED, TO AVOID ELECTRICAL SHOCK, FIRE, OR INJURY, USE ONLY PARTS IDENTICAL TO THOSE IN THE PARTS LIST. REASSEMBLE EXACTLY AS THE ORIGINAL ASSEMBLY TO AVOID ELECTRICAL SHOCK.

TROUBLE SHOOTING

Use this section to help you to try and solve any problems you may have:

PROBLEM	POSSIBLE CAUSES	REMEDIES
Blade stuck	There may be small twigs stuck in, or there may be large wet leaves and other leaves that are too large, mixed with wet soil.	Caused by irregular operation, please read the manual carefully and standardize the operation

NOTE: IF YOU EXPERIENCE A PROBLEM WITH YOUR PRODUCT, PLEASE DO NOT ATTEMPT TO OPEN OR REPAIR THE PRODUCT YOURSELF. DOING SO MAY VOID THE WARRANTY AND COULD CAUSE DAMAGE OR PERSONAL INJURY. IF THE PROBLEM STILL PERSISTS, PLEASE CONTACT US BY REFERRING TO THE SERVICE & SUPPORT INFORMATION ON THE FOLLOWING PAGE.

DECLARATION OF CONFORMITY / PERFORMANCE



Product Code: 18783/DT2260F

Product Description: Hawksmoor 2600W Electric Blower Vacuum

1.Toolstation Limited, Express Park, Bristol Road, Bridgwater, Somerset TA6 4RN

This declaration of conformity is issued under the sole responsibility of Toolstation

2.Object of the declaration

The object of the declaration described above is in conformity with the relevant Community harmonization legislation:

Supply of Machinery (Safety) Regulations 2008
2006/42/EC

Electromagnetic Compatibility Regulations 2016
2014/30/EU

The Restriction of the Use of Certain Hazardous Substances in Electrical and Electronic Equipment
Regulations 2012

2011/65/EU&(EU)2015/863

Noise Emission in the Environment by Equipment for use Outdoors Regulations 2001
2000/14/EC amended by 2005/88/EC:

- | | |
|--|-------------|
| - Conformity Assessment Procedure as per | Annex V |
| - Measured Sound Power Level | 102.4 dB(A) |
| - Declared Guaranteed Sound Power Level | 105 dB(A) |

3.References to the relevant standards used (or references to the specifications in relation to which conformity is declared:

BS EN 60335-1, BS EN 50636-2-100, BS EN 62233, AfPS GS 2019:01 PAK
BS EN 55014-1, BS EN 55014-2, BS EN IEC 61000-3-2, BS EN 61000-3-3

4.Additional information:

Signed for and on behalf of Toolstation Limited

ENVIRONMENTAL INFORMATION



The symbol on the product or its packaging indicates that this product must not be disposed of with your other household waste. Instead, it is your responsibility to dispose of your waste equipment by handing it over to a designated collection point for the recycling of waste electrical and electronic equipment. The separate collection and recycling of your waste equipment at the time of disposal will help conserve natural resources and ensure that it is recycled in a manner that protects human health and the environment. For more information about where you can drop off your waste for recycling, please contact your local authority, or where you purchased your product.

GUARANTEE

Toolstation products deliver reliable service for normal, household use in domestic settings. All Toolstation products are individually tested before leaving the factory.

If you are a consumer and you experience a problem with your Toolstation product, which is found to be defective due to faulty materials or workmanship within the Guarantee Period, this Toolstation Guarantee will cover repair or - at the discretion of Toolstation - replacement with a functionally equivalent Toolstation product.

Your product is under guarantee for 2 year from the date of purchase or the date of delivery of the product, if later.

The guarantee is subject to the following provisions:

- The guarantee does not cover accidental damage, misuse, cabinet parts, knobs, or consumable items.
- The product must be correctly installed and operated in accordance with the instructions contained in this manual.
- It must be used solely for domestic purpose.
- The guarantee will be rendered invalid if the product is re-sold or has been damaged by inexpert repair.
- Specifications are subject to change without notice.
- The manufacturer disclaims any liability for the incidental or consequential damages.
- The guarantee is in addition to, and does not diminish your statutory or legal rights.

CUSTOMER SUPPORT

www.coreservice.co.uk

Call us +44 01904 947568

Email: support@coreservice.co.uk

Made in China