

Code:

ST90CP10-53

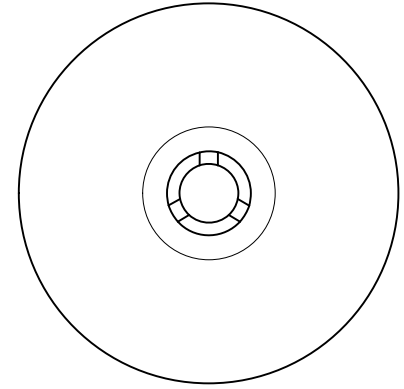

CP Plastic Grid

Part No.	Code
1	40M
2	ABSCON-BDY-40X1.5
3	KITBAG-M5X40PZCS
a	P-B-4X6 (Bag)
b	P-M5X40-PZCSK
4	L-ST90XXXX-53 (Leaflet)
5	P-C-S1H (Carton)
6	P-C-ST90 (Carton)
7	P-L-ST90CP10-53 (Label)
8	P-R-110MMDWFS
9	P-STW90RING-SL
10	ST70-OUTLETNUT
11	ST90MECPTOP+SUPP
a	P-SSHEXM6X20
b	STW90GRID-MECP
c	STW90GRID-SUP-GR
12	STW9030T/B3H-SUB
a	P-OR-055.00-2.00
b	STW9030T/B3H-SPIN
i	SPINWELD
ii	STW90-LID-3HF+5MM
iii	P-5MM-INSERT
iv	STW90-LID-3H-FLAT
v	STW9030TRAPBODY
c	STW90WASTE-3H-25
13	STW90WASTESEAL
14	STWSEAL-3H

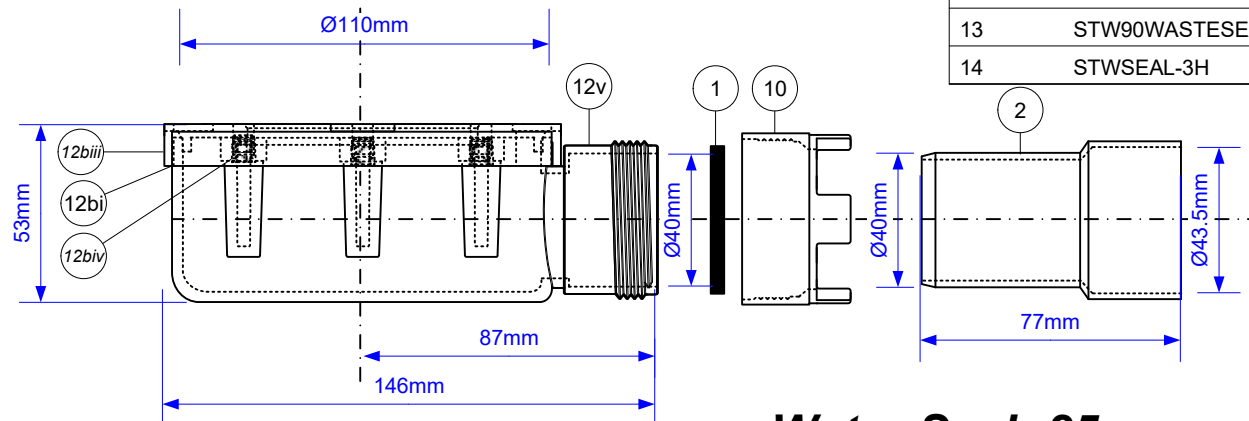
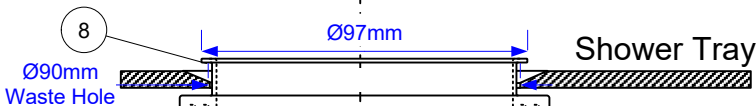
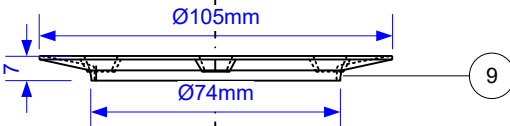
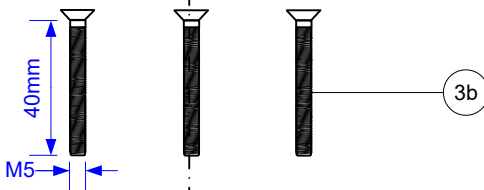
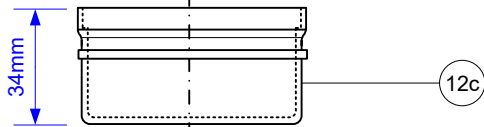
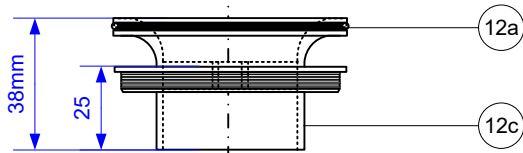
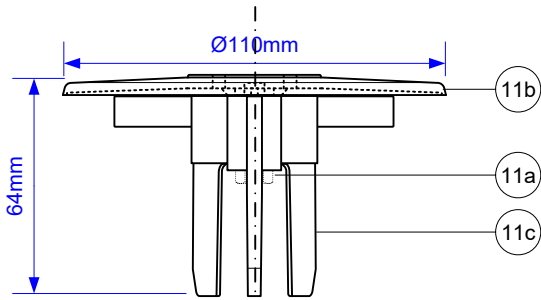

Water Seal: 25mm



Drawing verified
correct as of:

16/11/2021
RM

DRAWN BY

RM

SCALE

1: 2.25

REVISED

03/12/2018, 05/08/2019
14/10/2019, 24/09/2020
16/11/2021

FILENAME

ST90CP10-53.VSD

DATE

16/11/2021