

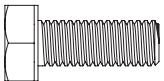
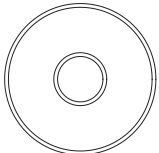
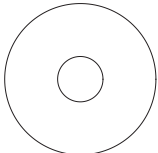
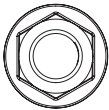
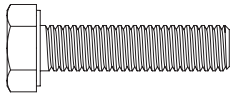
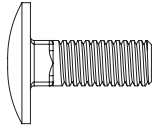

IN8087

ULTI Bars - X4

FX4012 X16 (M6X16) 	FX4013 X24 (M6) 	FX4014 X24 (RUBBER) 	FX4016 X32 (M6) 	FX4021 X16 (M6X25) 	FX4042 X16 (M6X16) 	MA6019 X2 	MA6020 X8 
MA6065 X8 	ME0203 X8 	ME0729 X1 	ME0730 X1 	ME0731 X4 	ME0732 X1 	ME0733 X1 	AS3190 X4 

TOOLS REQUIRED

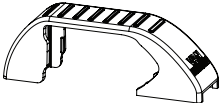
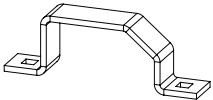
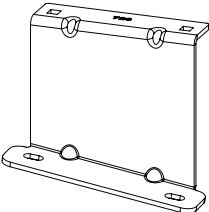
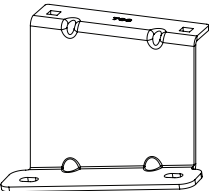
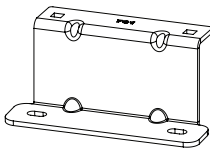
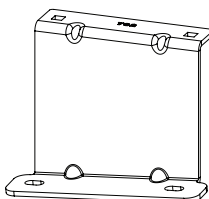
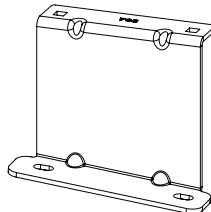
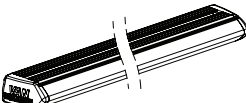
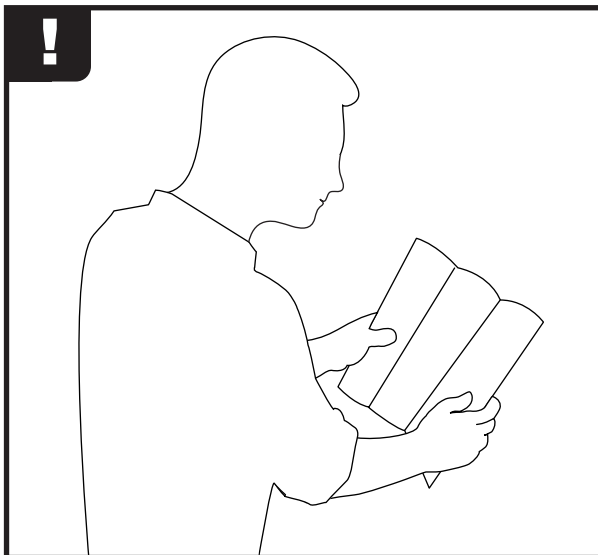
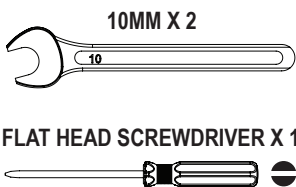

GB. Tested to 80kg per bar. Maximum load is in accordance with the vehicle manufacturer's load bearing capacity (refer to the vehicle handbook). **Do not exceed this limit.**



FR. Testé à 80 kg par barre. La charge maximale doit être conforme à la capacité de charge du constructeur de véhicule (veuillez- vous référer au livret du véhicule). **Ne dépassez pas cette limite.**



DE. Geprüft bis 80kg pro bar. Die Maximallast steht im Einklang mit der angegebenen Ladekapazität des Fahrzeugherstellers (diese finden Sie im Fahrzeughandbuch). **Die Maximallast darf nicht überschritten werden.**



DK. Testet til 80 kg pr. bar. Maksimal lasteevne afhænger af varevognproducentens angivelser i varevognens håndbog. **Overskrid ikke denne grænse.**

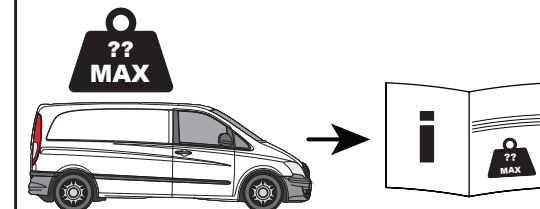
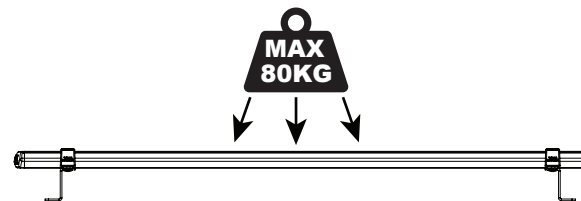

This FITTING INSTRUCTION is the property of VAN GUARD ACCESSORIES LTD. and must not be used for manufacturing purposes, copied nor communicated in any way to third parties without written permission from VAN GUARD ACCESSORIES LTD.

IN8087_F

Van Guard Accessories Ltd
Fair Oak Close, Exeter Airport Business Park,
Exeter, Devon, EX5 2UL
www.van-guard.co.uk

VG264-4

Vehicle:
Mercedes Vito: 2004 on
Wheel Base: Compact (L1)
Roof Height: Low (H1)
Rear Doors: Twin / Tailgate

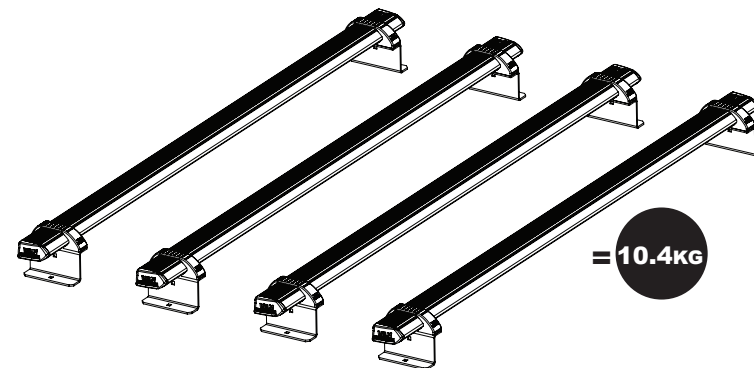
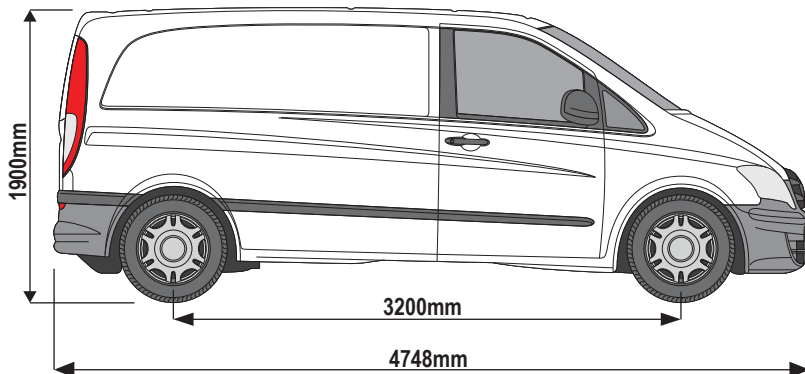

VG264-4

Vehicle:
Mercedes Vito: 2004 on
Wheel Base: Long (L2)
Roof Height: Low (H1)
Rear Doors: Twin / Tailgate

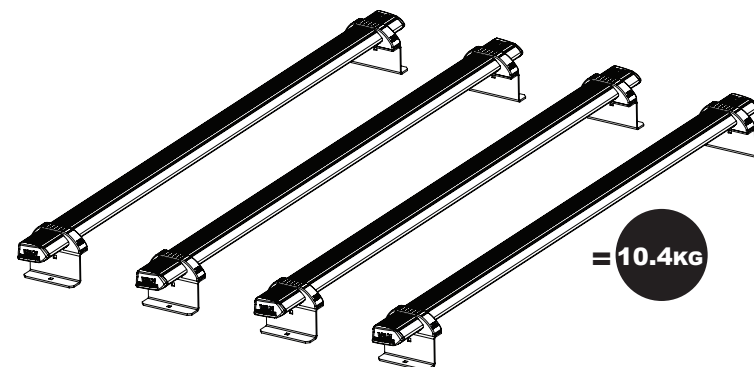
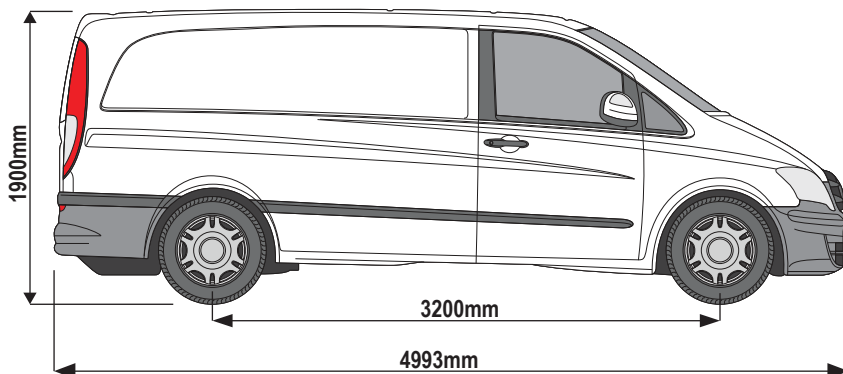

VG264-4

Vehicle:
Mercedes Vito: 2004 on
Wheel Base: Extra Long (L3)
Roof Height: Low (H1)
Rear Doors: Twin / Tailgate

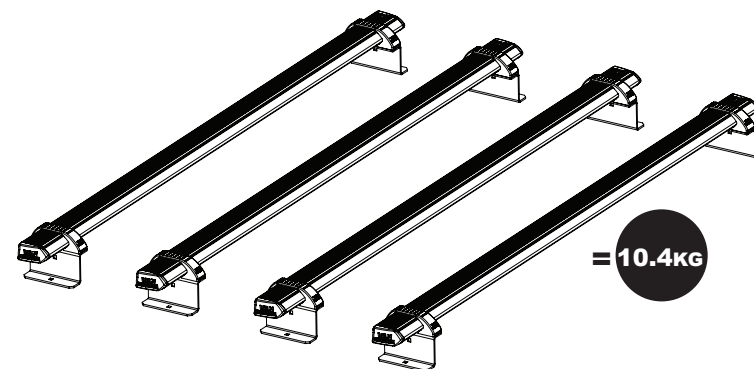
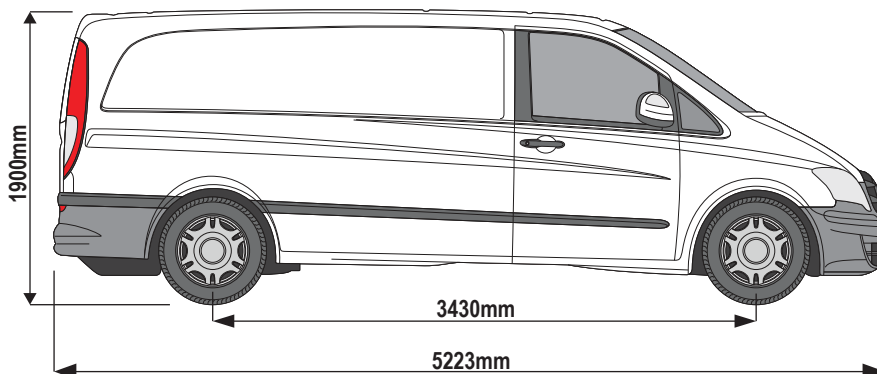

1

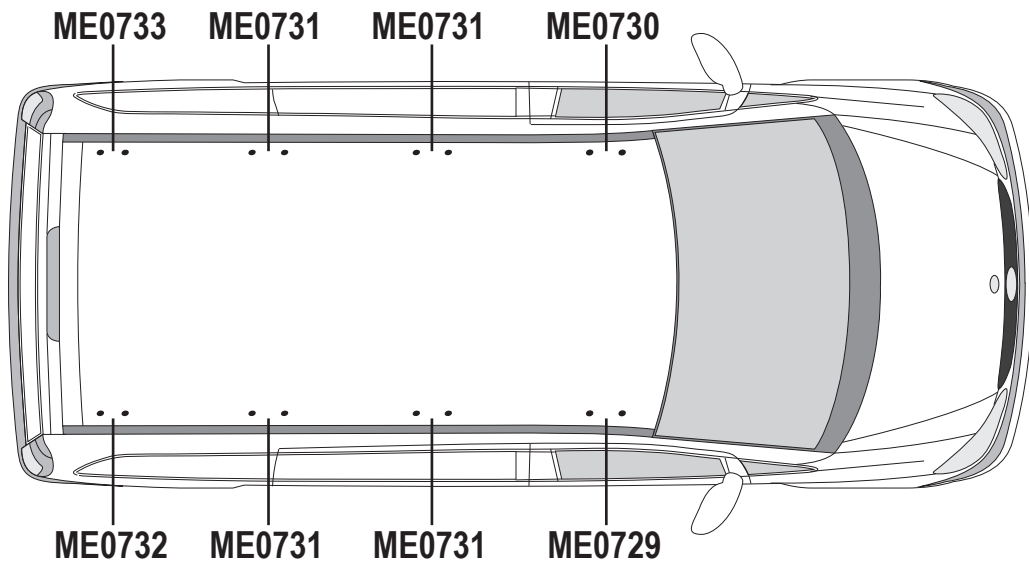

ME0729

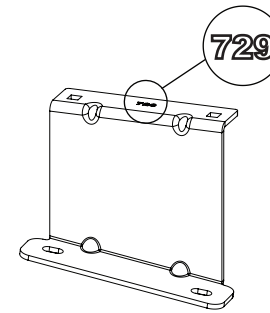

ME0730

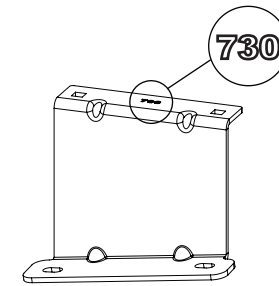

ME0731

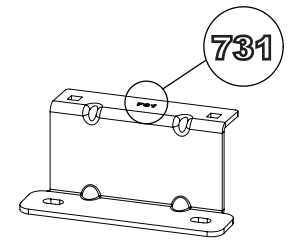

ME0732

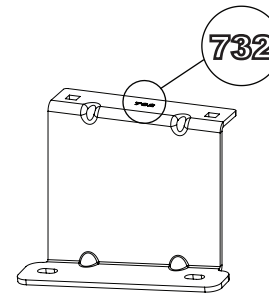

ME0733

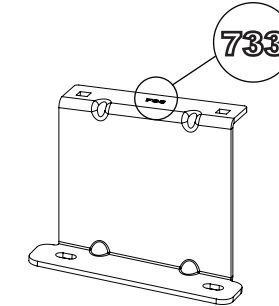

2

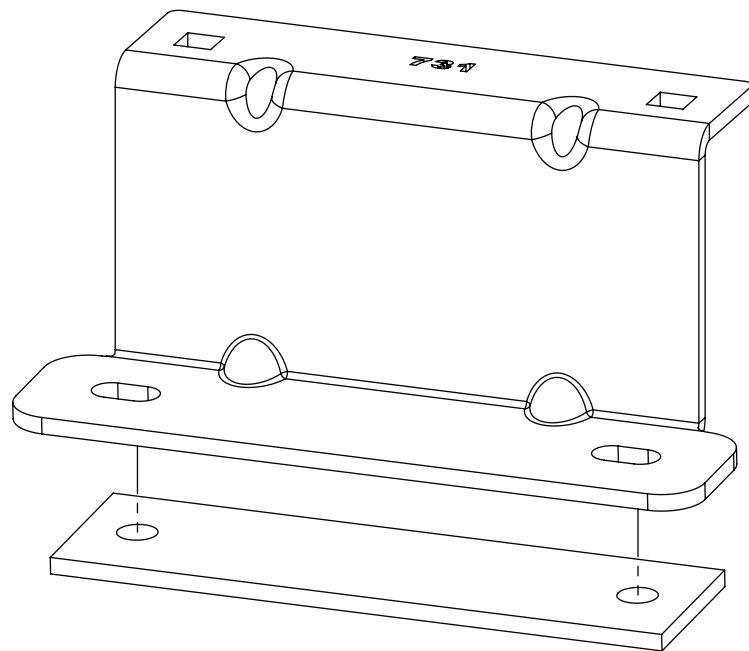

3

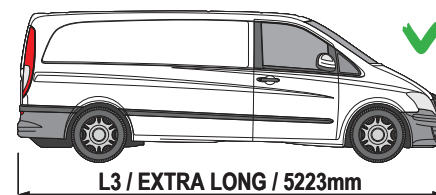
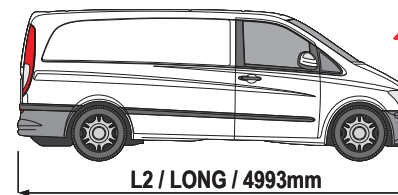
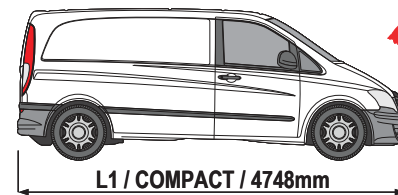

ME0732

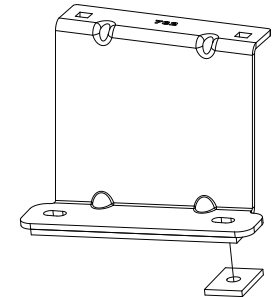

ME0733

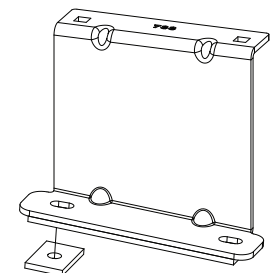

4

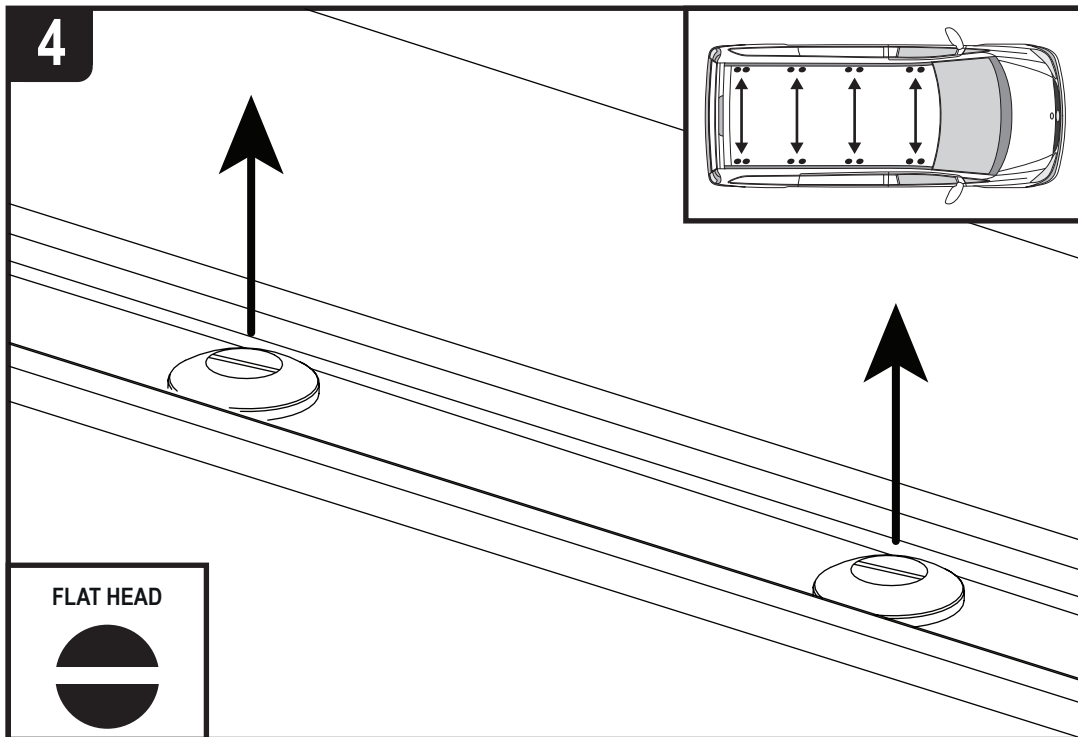

5

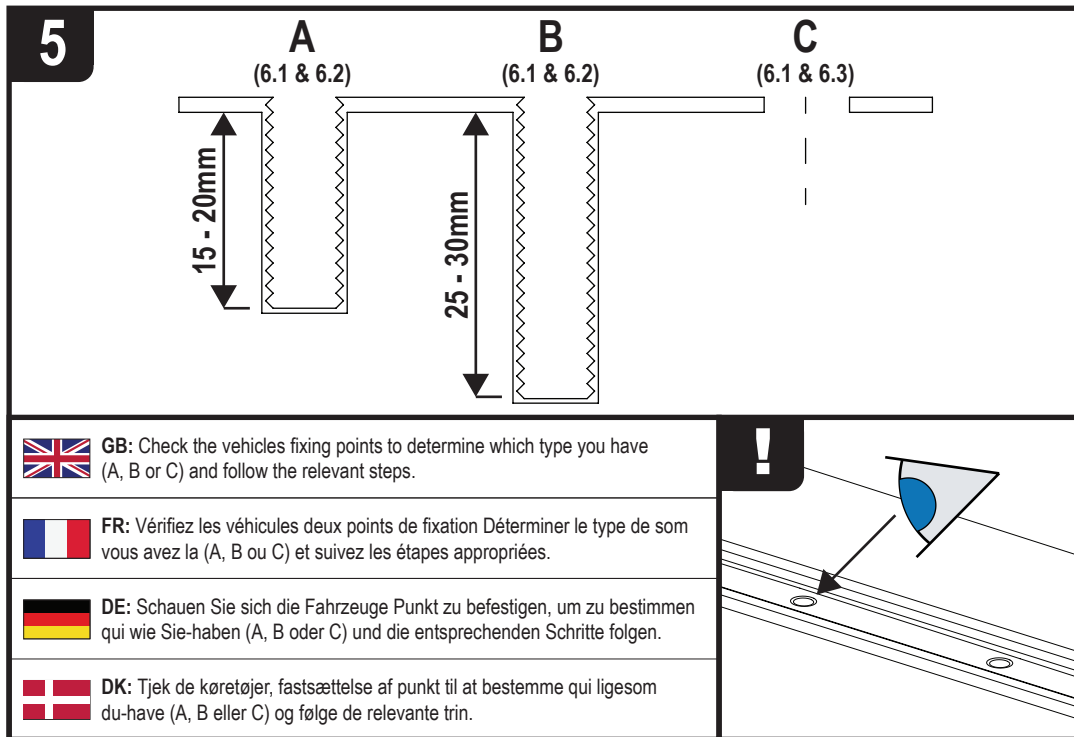

6.1

A + B + C

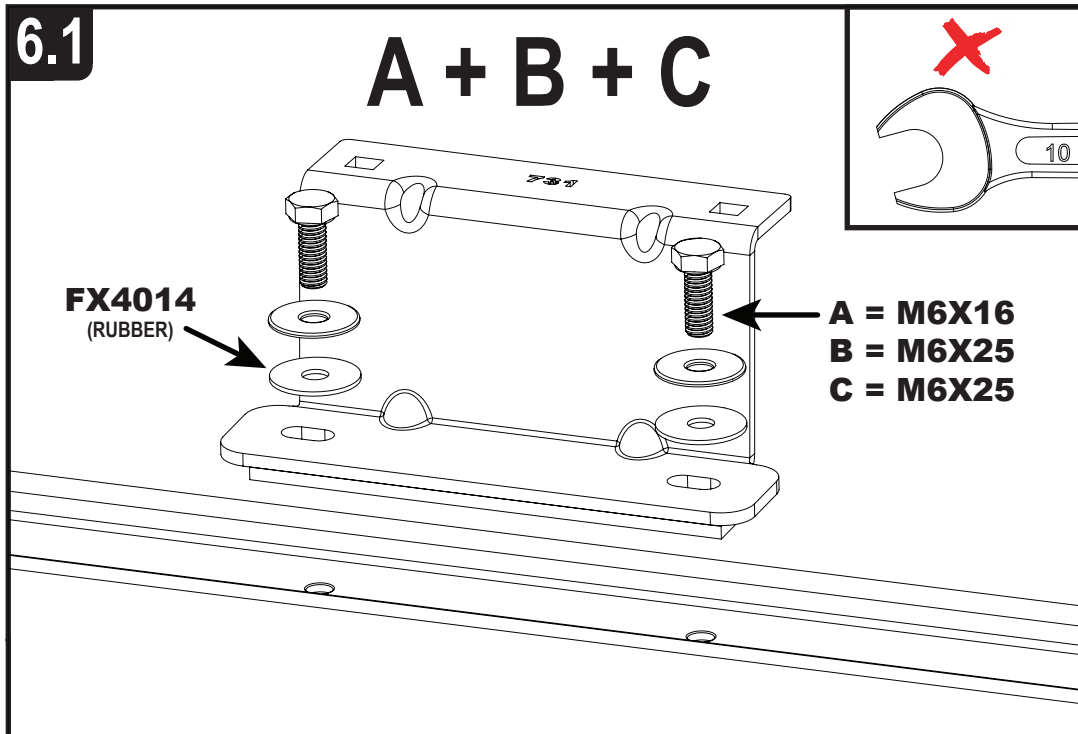

6.2

A + B

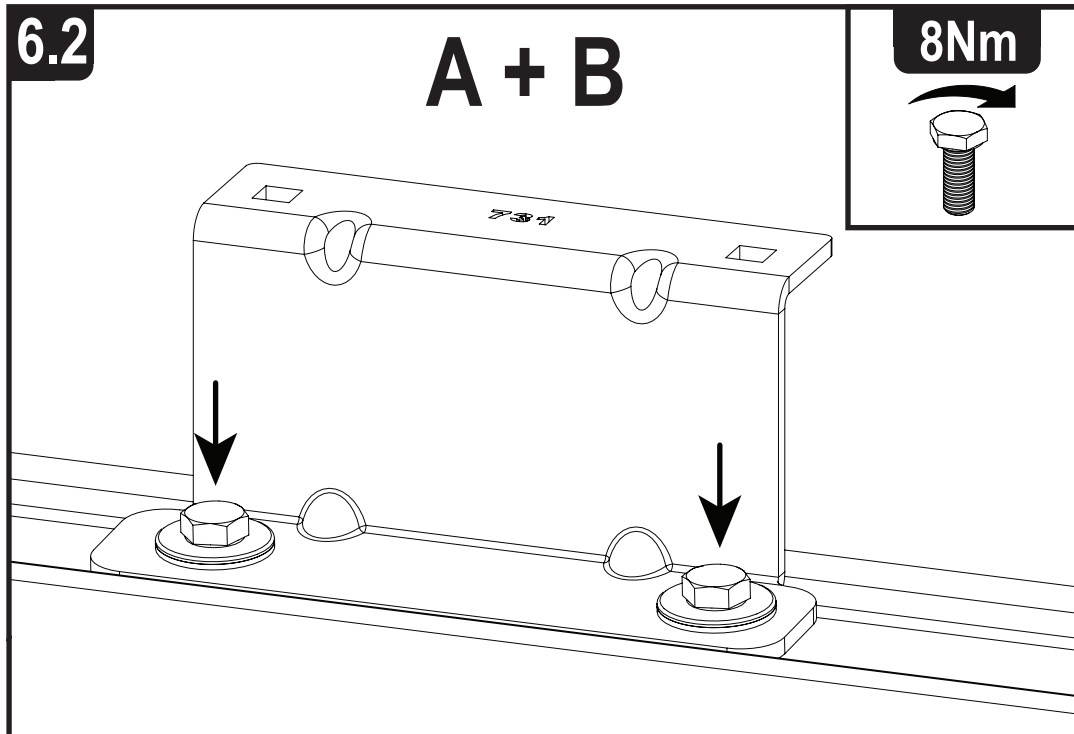

6.3

C

8Nm

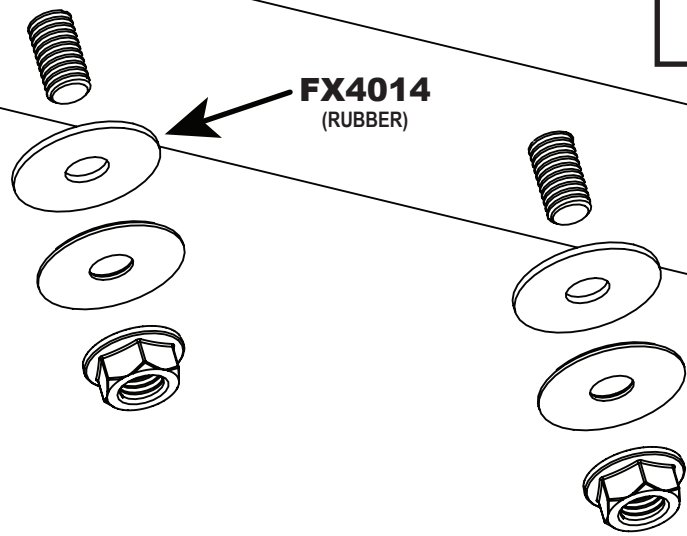
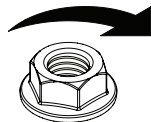

7

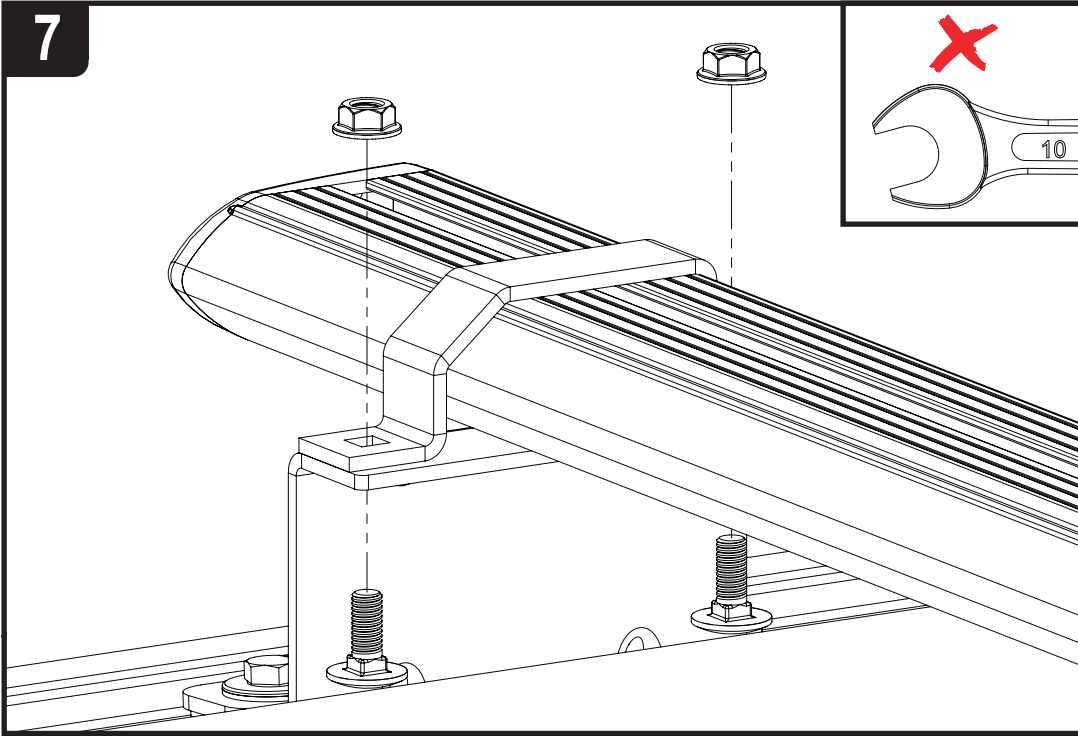

8

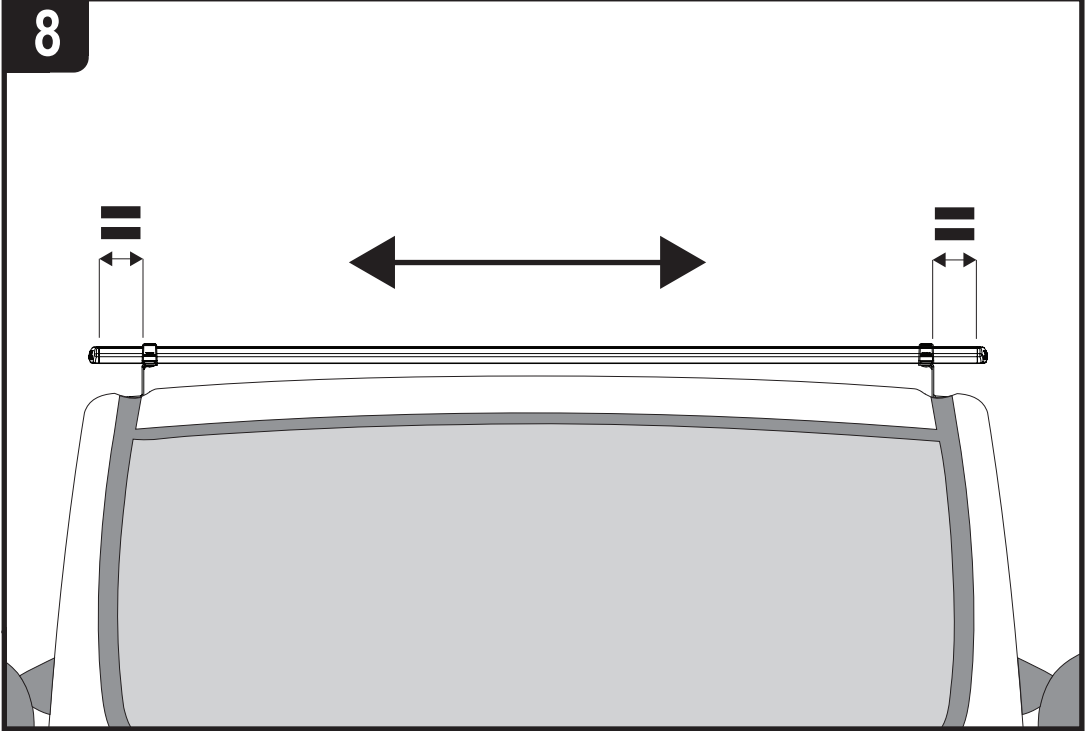

9

8Nm

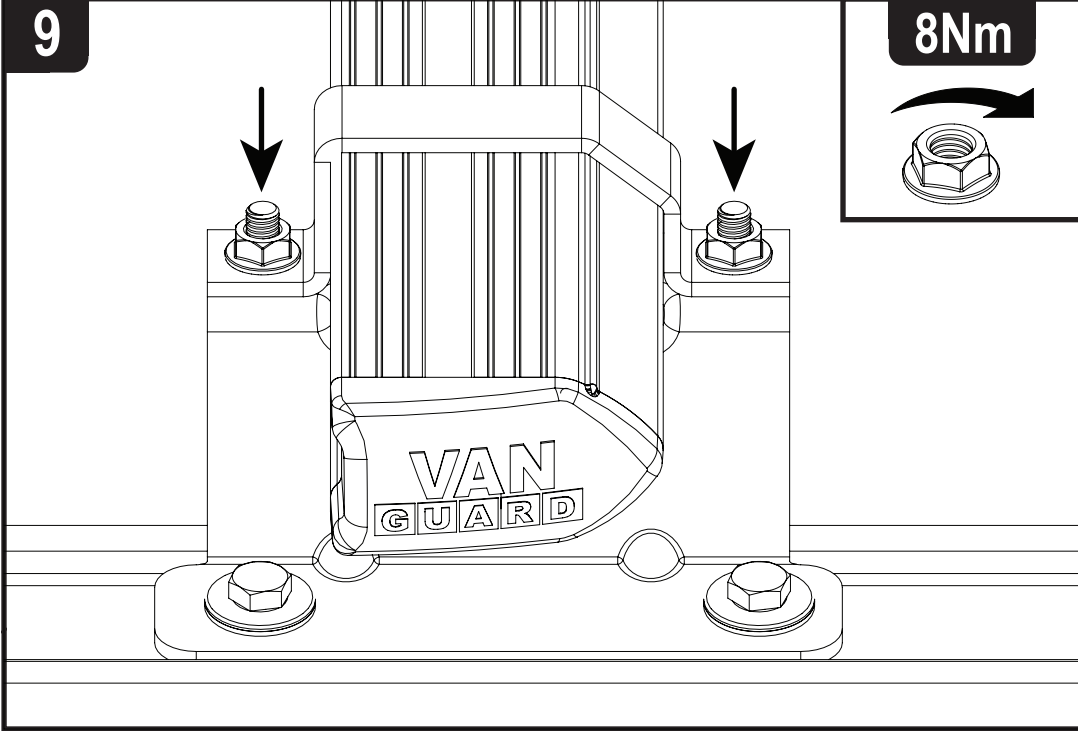

1.

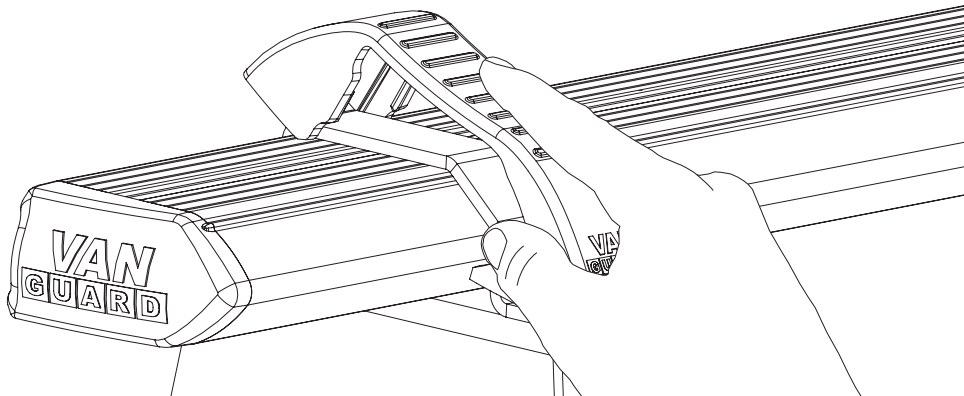

2.

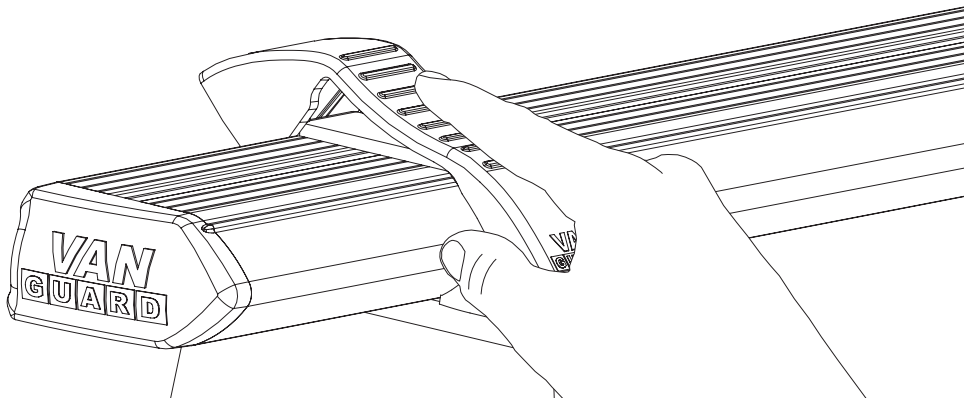

3.

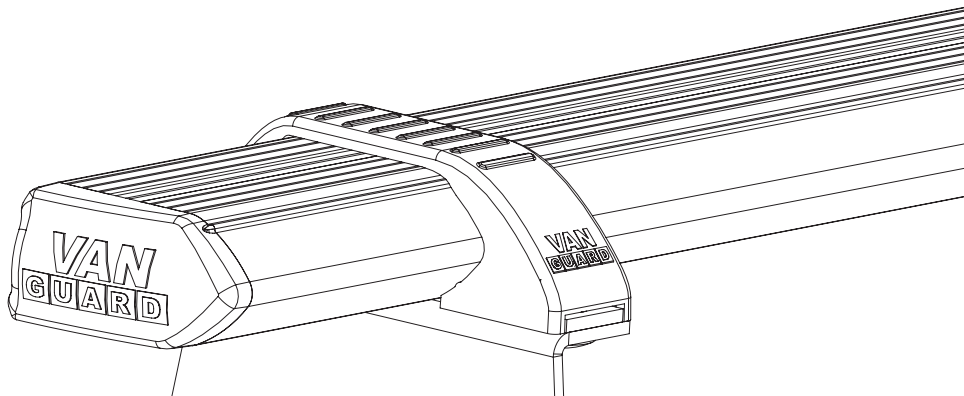

GB

1. Regularly inspect all fixings and parts. Any damaged or worn parts should be immediately removed from the vehicle and replaced.

2. Take care when loading and unloading goods on to and off the vehicles roof.

3. Van Guard Accessories LTD and/ or its distributors do not accept liability for:

- Any products that have been fitted incorrectly.
- Any products which have been fitted to the incorrect vehicle.
- Any products that have been modified in any way or are being used for any purpose that they are unintended for.

4. It is important that the end user receives this document and that instructions are retained for future use.



FR

1. Inspecter régulièrement toutes les fixations et les pièces. Les pièces endommagées ou usées doivent être immédiatement retiré du véhicule et remplacé.

2. Prendre garde lors du chargement et du déchargement de marchandises vers et hors des véhicules toit.

3. Van Guard Accessoires Ltd et/ ou ses distributeurs n'accepte pas de responsabilité pour:

- Les produits qui ont été ajustés de manière incorrecte.
- Les produits qui ont été montés sur le véhicule incorrect.
- Les produits qui ont été modifiés de quelque façon ou sont utilisés à toutes fins qu'ils sont involontaires.

4. Il est important que l'utilisateur final reçoit ce document et que les instructions soient conservés pour une utilisation futur.



DE

1. Prüfen Sie regelmäßig alle Befestigungen und Teile. Alle verschlissenen oder beschädigten Teile sollten sofort aus dem Fahrzeug ausgebaut und erneuert.

2. Vorsicht beim Be- und Entladen von Gütern auf und abseits der Fahrzeuge.

3. Van Guard Accessories LTD und/ oder seinen Händlern keine Haftung für:

- Sämtliche Produkte, die falsch montiert worden.
- Alle Produkte, die auf die falsche Fahrzeug.
- Alle Produkte, die nicht in irgendeiner Weise verändert oder verwendet für jeden Zweck, sie sind unbeabsichtigt.

4. Es ist wichtig, dass der Endbenutzer erhält dieses Dokument und die Anweisungen für eine zukünftige Verwendung aufbewahrt werden.



DK

1. Undersøg med jævne mellemrum alle løsele og fæstninger. Beskadigede eller slidte dele bør straks fjernes fra køretøjet og repareres eller erstattet.

2. Vær meget opmærksom ved lastning og losning af varer fra varevognens tag.

3. VanGuard Accessories Ltd og/eller deres distributører accepterer ikke ansvar for:

- Produkter der ikke er monteret korrekt som angivet i monteringsvejledning.
- Produkter der er blevet monteret på et køretøj, de ikke er beregnede til.
- Produkter der er blevet modificerede på nogen måde eller bliver brugt på en måde, hvortil de ikke er beregnede.

4. Det er vigtigt, at dette dokument overdrages til slutbruger af produktet og at vejledning er gemt til senere brug.