

# ebb+flo

**User Instructions**

## **Cool Touch Thermostatic Bar Diverter Mixer Shower**

**81971 (V1)**

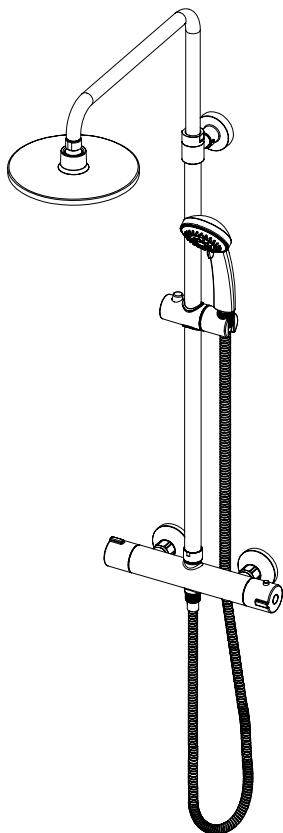

**PLEASE KEEP THESE INSTRUCTIONS FOR FUTURE REFERENCE**

## WHAT'S IN THE BOX

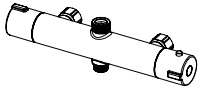

Bar valve x1



Sealing washer x2



Wall Plate x2



Eccentric unions x2



Fixing Bracket x1



Wall screw x1



Wall plug x1



Hexagonal key x1



Shower hose x1



Handset x1



Showerhead x1

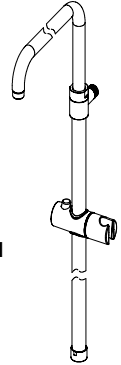

Shower tube assembly x1

If you need any help, please contact us:

0808 100 7211 or 0330 333 3303

## TOOLS REQUIRED ( tools not supplied )

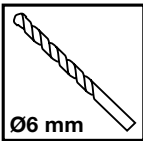
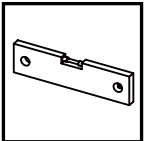
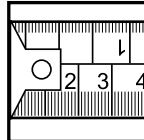
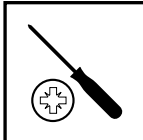
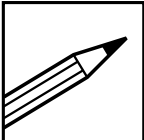

Ø6 mm

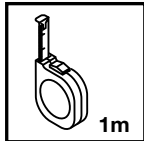

1m

## HEALTH AND SAFETY

- Identify all components and check pack contents.
- Turn off mains water supply.
- Prior to drilling into walls, check that there are no hidden electrical wires, cables or water supply pipes. This can be checked with the aid of an electronic detector.
- Wear eye protection.

## WATER SUPPLY TEMPERATURE

Hot Water Maximum: 70°C

Recommended 60-65°C

Cold Water Minimum: 5°C

Recommended 10-15°C

Operating Pressure Range: Min. 0.5 bar, max. 5.0 bar

Always maintain a 10°C difference between hot system temperature and maximum hot setting of valve.

Hot and Cold Maximum pressure differential should be no more than 2 bars. If this limit is exceeded, fit a pressure reducing valve (not supplied).

Operating pressures on hot and cold lines should be kept as even as possible in order to ensure the maximum efficiency of the mixer.

When water pressure is higher than 5 bar a pressure reducing valve (not supplied) must be fitted before the mixer.

Flow restrictors (not supplied) can be fitted into the wall unions to reduce water consumption on high pressure system.

## ASSEMBLY AND USE

1. Flush pipe work prior to installation to remove debris from the system.
2. Turn off water supply following system flushing.
3. Install the ½ inch section of the Eccentric union (4) to the supply pipes (the centres are 140-160mm) being sure to fit adequate seals (not supplied). Ensure that the Eccentric unions (4) on the same lever, the centre of the 2x Eccentric unions (4) are 150±1 mm.

Note: these Unions are not compression fittings.

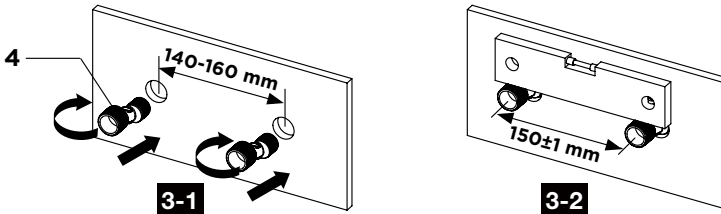

4. From the front, align the Eccentric Unions (4) with the Bar Valve (1) inlets. Screw Flange (3) to the ¾ inch section of the Eccentric Unions (4) protruding through the wall. Sealant can be used between the Flange (3) and the wall.

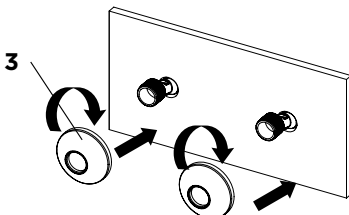

**5. Install Bar Valve (1) with sealing washer (2) to the Eccentric Unions (4).**

**Note:** the outlet of the bar valve to be downward, the cold inlet (indicated by a blue dot on the rear of the mixer) to the right. then tighten the nuts of the Bar Valve (1) until secure.

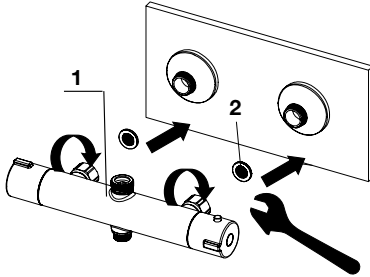

**6. Using a level, measure from the central point, vertical to 747mm and mark, as shown.**

**7. Drill and prepare fixings for the fixing bracket using the components supplied (if suitable).**

**8. Insert the wall plug (7), Secure the fixing bracket (5) using the supplied wall screw (6, if suitable). use the orientation of the fixing bracket (5) and the slotted fixing to allow for minor adjustments.**

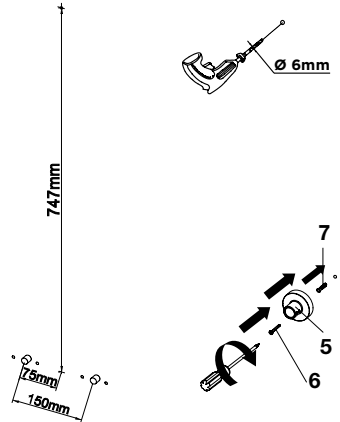

**9. The telescopic section of the riser can adjust the height between 840-1170mm, loosen the fixing nut on the rail bracket, adjust to the desired height and re-tighten the fixing nut.**

**10. Position the shower tube assembly (12) on the bar valve outlet, Ensure the sealing washer is in the outlet, hand tighten the nut to allow enough free movement to gauge a fit.**

**11. Tilt the shower tube assembly (12) back and slot the rail bracket into the fixing bracket (5), hold in place by gently tightening the grub screws using 2.5 mm hexagonal key (8).**

**Note:** You can make a minor adjustment to the fixing bracket (5) to ensure the shower tube is level and tighten grub screws to secure.

**12. Tighten the fixing nuts of the shower tube using a suitable tool, taking care not to overtighten.**

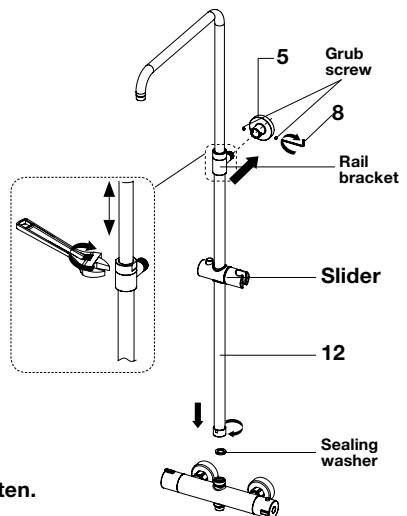

13. Turn on water supplies and check for leaks.
14. Ensuring the hose washer is in position, attach the non-conical end of the shower hose (9) to the bar valve. Run the shower for a few seconds to clear any debris that may be present. Then attach the conical end of the shower hose (9) to the handset (10), then place the hose in the slider.
15. Ensure the hose washer is in place, screw the shower head (11) onto the arm, taking care not to damage the plated surface. Tighten carefully using a suitable tool taking care not to overtighten.

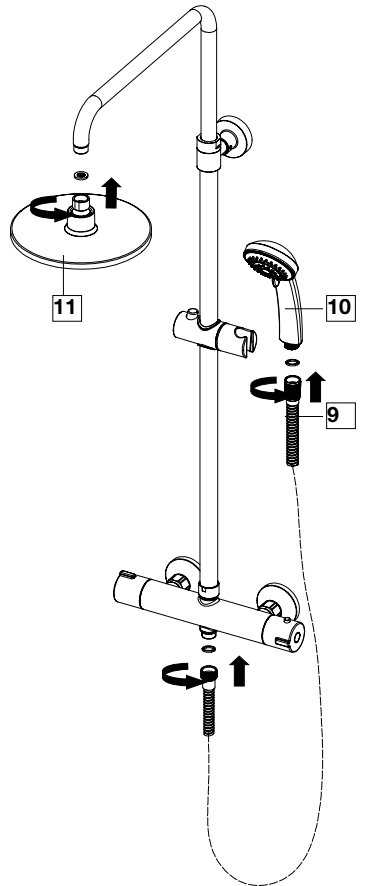

## TEMPERATURE SETTING (TO BE DONE ONLY WHEN ESSENTIAL)

This mixer has been set in the factory under balanced pressures and hot water supply at 65°C.

When your operating conditions vary significantly from the above, the temperature of the mixed water may vary from the setting. In this case, you can set the temperature of the mixer to suit your requirements.

The valve is set to a maximum 48°C. This can be checked if required using a thermometer. If this temperature is incorrect, you can reset it as the following:

1. Turn the handle to 38°C position.
2. Remove handle cap, then the handle screw, then the temperature handle.
3. Without removing the black stop, turn the spindle of thermostatic valve until the temperature is at the required level.
4. Test again using a thermometer.
5. When the required temperature is reached, re-fit the components, so that the chrome button stop will be at your new set temperature.

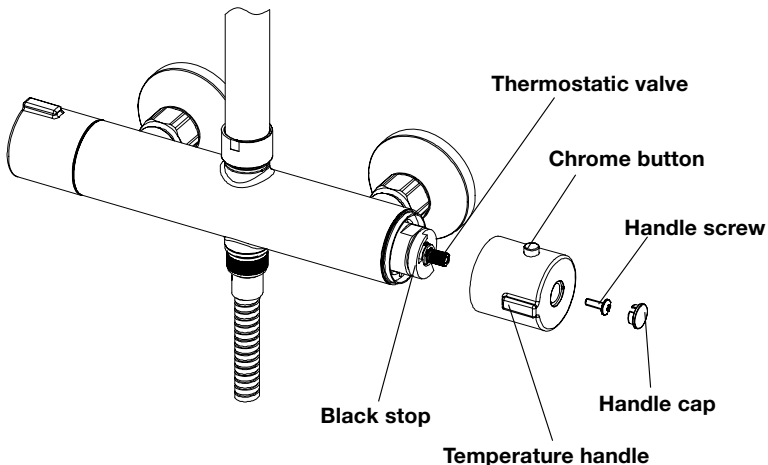

## MAINTENANCE

### Cleaning the flow cartridge

- (1) Before carrying out any maintenance, turn off the mains water supply. If unsure contact a qualified tradesman.
- (2) Remove the cap (1), grub screw (2), flow handle (3).
- (3) Unscrew the retaining nut (4) using a suitable spanner, then remove the diverter cartridge (5), clean the diverter cartridge (5) rinse thoroughly under cold water to remove any build up of limescale or debris.
- (4) If necessary replace the diverter cartridge (5).
- (5) Re-fit the diverter cartridge (5) into the body, tighten the Retaining Nut (4) using a suitable spanner.
- (6) Re-fit the flow handle (3), tighten the grub screw (2) and re-fit cap (1) to handle (3).

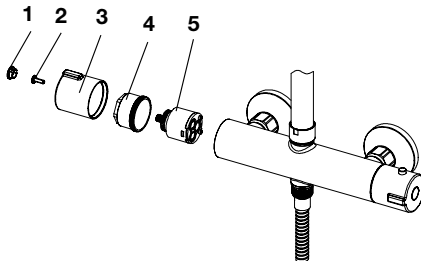

### Cleaning the thermostatic cartridge

- (1) Before carrying out any maintenance, turn off the mains water supply. If unsure contact a qualified tradesman.
- (2) Remove the cap (1), grub screw (2), temperature handle (6).
- (3) Pull the black stop (7) from the cartridge (9). Remove the retaining nut (8) using a suitable spanner, remove and clean the thermostatic cartridge (9) rinse thoroughly under cold water to remove any build up of limescale or debris. Note: take note of the position of the black stop (7) and cartridge (9), they must be re-fitted in the same position.
- (4) Replace the cartridge (9) into the body, tighten the retaining nut (8) using a suitable spanner.
- (5) Re-fit the black stop (7), temperature handle (6), tighten the grub screw (2) and re-fit cap (1) to handle.

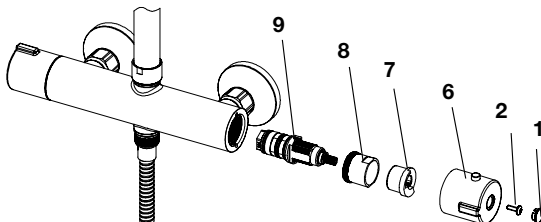

## TROUBLESHOOTING

Symptom	Cause	Remedy
No flow or low flow rate and /or varying temperatures.	Check showerhead, hose and filters for any blockage.	Clean as necessary. Refer to Aftercare section (page 7).
	Partially closed stop or service valve in water supply pipework to the shower valve.	Open stop or service valve.
	Instantaneous water heater cycles on and off as the flow rate or pressure is too low.	Increase water flow rate or pressure through system. Contact the boiler manufacturer.
	Head of water is below the minimum distance required.	Raise the cistern or fit a shower booster pump.
	Inlet filter is partially blocked.	Clean or replace, flush through pipework before refitting.
	Hot or cold water being drawn off elsewhere causing pressure changes or instantaneous boiler temperature changes.	Do not use other water outlets when using the shower.
	Make sure the maintained inlet pressures are nominally balanced and sufficient.	Refer to Water Supply Temperature (page 3).
	Airlock or partial blockage of the pipework.	Flush through pipework to ensure removal of debris and any airlocks.
Only hot or cold water from the shower valve outlet.	No hot or cold water reaching the shower valve.	Check hot and cold feeds (the valve will shut down if either the hot or cold supply fails).
	Partially closed stop or service valve in water supply pipework to the shower valve.	Open stop or service valve.
	Inlet filter is partially blocked.	Clean or replace, flush through pipework before refitting.
Water leaking from showerhead.	Inlet water supplies are reversed (hot to cold supply).	Check the connections are the correct way round. Hot on the left and cold on the right when viewed from the front. Rework pipework as necessary.
	This is normal for a short time after turning off.	Adjust angle of showerhead in holder as necessary to vary draining time.
Maximum water temperature too hot or cold.	Shower flow valve failing to close fully, possibly due to water borne debris.	Remove flow valve and check. Refer to Aftercare section (page 7) before dismantling shower valve.
	Maximum water temperature set incorrectly.	Reset maximum water temperature. Refer to Temperature setting (page 6).
Outlet water temperature too hot / cold.	Inlet filter is partially blocked.	Check inlet filters for any blockages and clean as necessary.
	Installation conditions outside operating parameters.	Refer to Water Supply Temperature (page 3). Refer to Aftercare section (page 7). Refer to Temperature setting (page 6).
Water temperature too cold Maximum water temperature incorrectly set.	Hot water temperature is less than 10°C above the required blend temperature.	Adjust hot water temperature or wait for water to reheat if stored system is used.
	Instantaneous water heater not igniting because water flow rate is too low.	Increase water flow rate through the system. Check inlet filters and clean or replace. Refer to Aftercare section (page 7). Contact the boiler manufacturer.

## CARE AND CLEANING

Whilst modern plating techniques are used in the manufacture of these fittings, the plating will wear if not cleaned properly. The safest way to clean your product is to wipe with a soft damp cloth. Stains can be removed using washing up liquid. All cleaning powders and liquids will damage the surface of your fitting even the non-scratch cleaners.

## TROUBLE SHOOTING

PROBLEM	CAUSE	REMEDY
No flow or low flow rate	Partially closed isolation valve.	Open isolation valve.
	Airlock or partial blockage in the supply pipework.	Flush through pipework to ensure removal of debris and any airlocks.

## CUSTOMER SUPPORT

[www.toolstation.com/contact](http://www.toolstation.com/contact)

Call us 0808 100 7211

Mobile friendly 0330 333 3303

Email [info@toolstation.com](mailto:info@toolstation.com)

Made in china