

Original User Instructions

Wessex High Speed/Floor Dryer

SKU: AI019

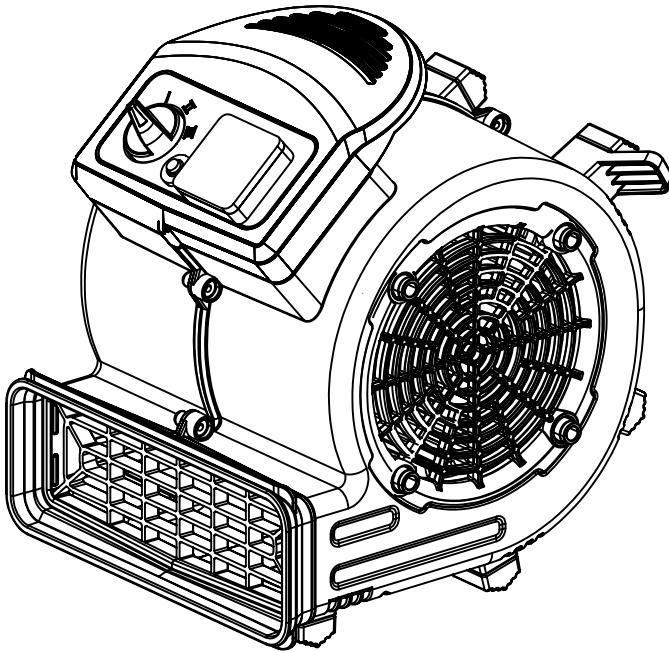

READ BEFORE USE

PLEASE KEEP THESE INSTRUCTIONS FOR FURTHER REFERENCE

CONTENTS

• WHAT'S IN THE BOX	3
• SPECIFICATIONS	4
• EXPLANATIONS AND SYMBOLS, CAUTIONS AND WARNINGS	5
• IMPORTANT SAFETY WARNINGS	6
• PRODUCT DESCRIPTION AND IDENTIFICATIONS	9
• OPERATING INSTRUCTIONS	10
• CARE AND CLEANING	13
• TROUBLESHOOTING	14
• DECLARATION OF CONFORMITY / PERFORMANCE	16
• ENVIRONMENTAL INFORMATION	17
• WARRANTY	18
• CUSTOMER SUPPORT	18

WHAT'S IN THE BOX

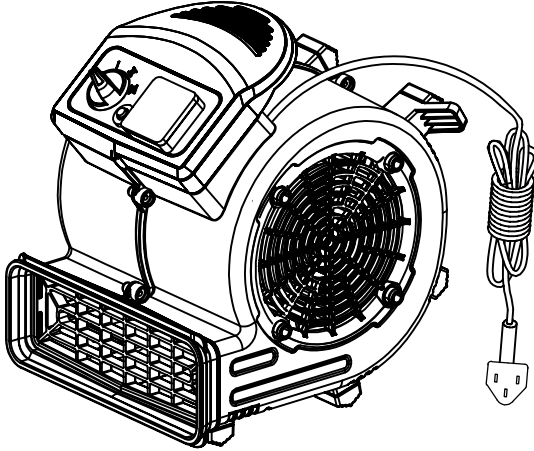

Floor Dryer x 1

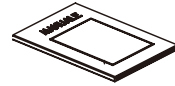

Manual x 1

If you do not have all these items, please contact:

www.coreservice.co.uk

Hotline: +44 01904 947568

Email support@coreservice.co.uk

SPECIFICATIONS

Technical Data	
SKU / Model	AI019 / JNC2-P
Rated voltage	220-240V~ 50Hz
Maximum load for extension socket	2100W
Rated power	124W
Speed settings	3
Air speed	13.5/14.5/16m/s
Operating positions	0°/45°/90°
Stackable	Yes
Protection class	Class I
Cable specification	H05VV-F 3G1.5mm ² , 3m, BS plug
Weight (approx.)	3.5 kg
Product Dimensions (approx.)	260 x 260 x 300mm

EXPLANATIONS AND SYMBOLS, CAUTIONS AND WARNINGS



Warning!



Read the instructions.



Wear a dust mask.



Wear hearing protection.



Class I tool



The product complies with the applicable European directives, and an evaluation method of conformity for these directives was done.



Recycle unwanted materials instead of disposing of them as household waste. All tools, hoses and packaging should be sorted, taken to the local recycling centre and disposed of in an environmentally safe way.



The product complies with the applicable UK directives and an evaluation method of conformity for these directives was followed.

IMPORTANT SAFETY WARNINGS



WARNING! Read all safety warnings, instructions, illustrations and specifications provided with this floor dryer.

Failure to follow all instructions listed below may result in electric shock, fire and/or serious injury.

Retain all warnings and instructions for future reference.

This appliance can be used by children aged 8 years and above, and persons with reduced physical, sensory, or mental capabilities, or lack of experience and knowledge, if they have been given supervision or instruction concerning the use of the appliance in a safe way and understand the hazards involved.

Children should not play with the appliance. Cleaning and maintenance should not be performed by children without supervision.

If the supply cord is damaged, it must be replaced by the manufacturer, its service agent or similarly qualified persons in order to avoid a hazard.

1. **IMPORTANT:** Read the operating instructions before assembling and using for the first time.
2. Check that the mains voltage is the same as the mains voltage specified on the rating plate.
3. Disconnect the appliance from the mains supply under the following circumstances: when it is not in use, before any attempt to open the casing, and before performing any cleaning or maintenance.

4. Never clean the appliance with solvents.
5. Never pull the plug out of the socket by pulling the cable.
6. Never leave the appliance unattended when ready for use.
7. Keep away from children and pets.
8. Take care to ensure that the power cable does not get damaged by being run over, crushed, pulled or similar.
9. Do not use the appliance if the power cable is in less than perfect condition.
10. If the power cable has to be replaced, the replacement must comply with the design specifications of the manufacturer.
11. Never use the appliance to blow the following items: burning matches, smoldering ash and cigarette butts, combustible, caustic, flammable or explosive substances, vapour or liquids.
12. This appliance is not suitable for blowing dust which can be harmful to your health.
13. Store the appliance in a dry indoor location.
14. Never use the appliance if it is damaged.
15. Have the appliance serviced only by an authorised after-sales service outlet.
16. Use the appliance only to carry out work for which it has been designed.
17. Take extra care when cleaning the steps.
18. Use only genuine accessories and spare parts.
19. Keep children and other persons away from the electric tool while it is being used. Allowing yourself to get distracted can cause you to lose control of the tool.

20. This appliance is equipped with an overload protection device which may shut down the unit during operation. To reduce the risk of injury from accidental starting, turn off unit and unplug power cord when not in use or before servicing.
21. This floor dryer must be grounded. If it should malfunction or break down, grounding provides a path of least resistance for electric current to reduce the risk of electric shock.
22. This floor dryer is for use on a nominal 220-240 V circuit, and has a grounded plug. The floor dryer should not be plugged into an outlet if it is not grounded. Do not use with an extension cord.

Service

Have your floor dryer serviced by a qualified repair person using only identical replacement parts. This will ensure that the safety of the floor dryer is maintained.

PRODUCT DESCRIPTION AND IDENTIFICATIONS

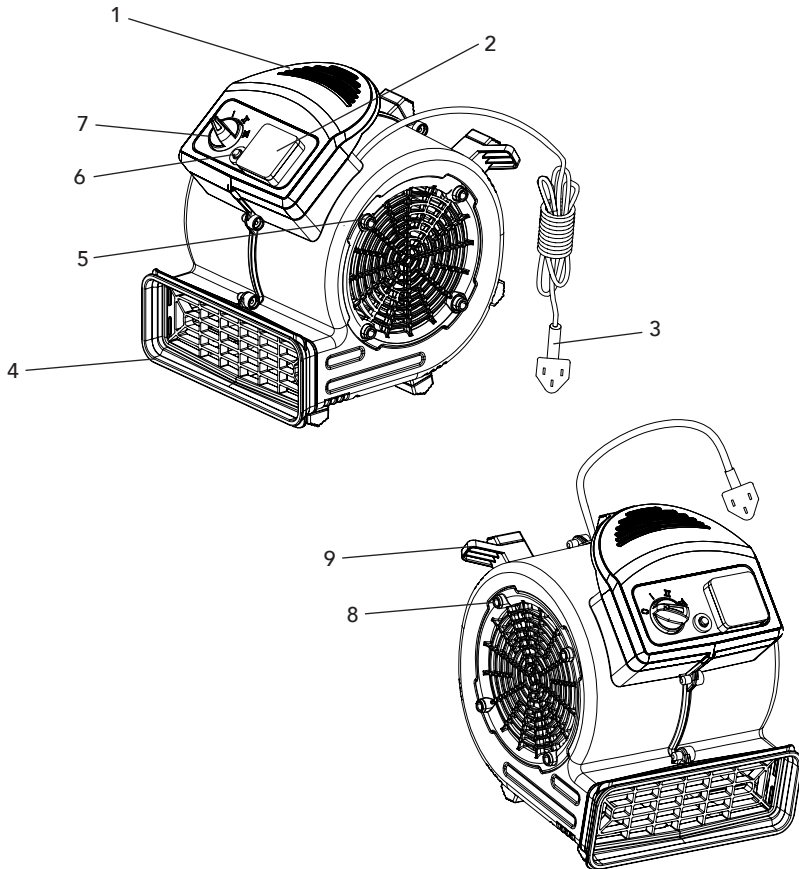

1. Handle/Cord wrap
2. Power extension socket
3. Power cord with BS plug
4. Air discharge grill
5. Receiver for stacking peg
6. Reset button
7. 3-Speed on/off switch
8. Peg for stacking on side
9. 3-Position anti-skid feet

Not all the accessories illustrated or described are included in standard delivery.

OPERATING INSTRUCTIONS

Intended Use: The high speed fan/floor dryer is designed for rapid drying and cooling for household use only. The appliance is not suitable for the operation around explosive, toxic, carcinogenic, or hazardous materials, liquids, vapors, or dusts.

The appliance is to be used only for its prescribed purpose. Any other use is deemed to be a case of misuse. The user / operator and not the manufacturer will be liable for any damage or injuries of any kind caused as a result of misuse. Please note that our equipment has not been designed for use in commercial, trade or industrial applications. Our warranty will be voided if the appliance is used in commercial, trade or industrial businesses or for equivalent purposes.



WARNING! To prevent serious injury from accidental operation, turn the power switch off and unplug the appliance from its electrical outlet before performing any procedure in this section.

Prior to connecting the floor dryer to the mains supply, ensure that the voltage and frequency indicated on the rating label match your mains supply.

To reduce the risk of electric shock, do not expose to rain or water.

To reduce the risk of electric shock, connect only to an outlet provided with a ground fault circuit interrupting device.

This is an automatically operated device - to reduce the risk of injury, disconnect from power supply before servicing.

Do not move or carry the floor dryer while it is operating.

Only operate on a level, stable surface to prevent the floor dryer from falling and potentially causing injury or damage to the unit or property.

Never operate this floor dryer with intake grills removed.

Do not run cord under carpeting. Do not cover cord with rugs, runners, or other coverings.

Do not route cord under furniture or appliances. Direct cord away from traffic areas where it will not be tripped over.

Do not put any object into intake openings. Do not operate floor dryer with any intake openings blocked.

Do not allow to be used as a toy. Close attention is necessary when used by or near children.

Direct air discharge at work area only; do not direct air at bystanders.

Do not leave floor dryer unattended when plugged in.

This floor dryer is equipped with an overload protection device which may shut down the unit during operation. To reduce the risk of injury from accidental starting, turn off unit and unplug power cord when not in use or before servicing.

Turn off floor dryer before unplugging.

Keep hair, loose clothing, fingers, and all parts of body away from openings and moving parts.

This floor dryer must be grounded. The plug must be inserted into an appropriate GFCI outlet.

Do not use with an extension cord.

Operation

1. Ensure that the 3-speed on/off switch is set to "0" (OFF) and the cord is unplugged.
2. Place the floor dryer in the desired position on a stable surface.
3. Plug in the floor dryer to an outlet.

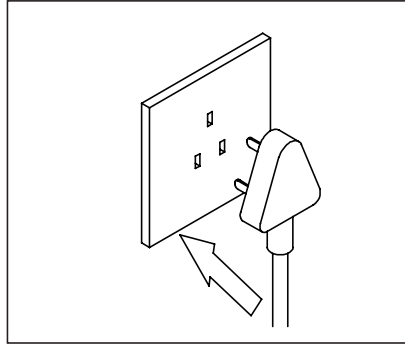

4. Turn on the appliance by rotating the 3-speed on/off switch clockwise to the desired speed
Speed I - 13.5m/s, Speed II - 14.5m/s, Speed III - 16m/s.

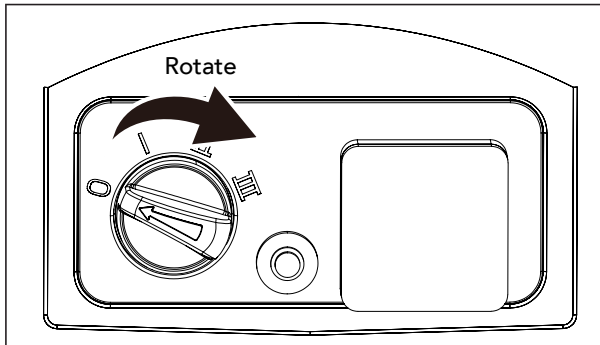

5. When finished with use, turn the 3-speed on/off switch counter-clockwise to the "0" (OFF) position and unplug the power cord from the outlet.

Operating positions

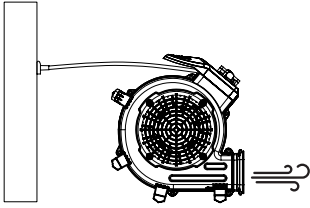

Carpet and Flooring (0°)

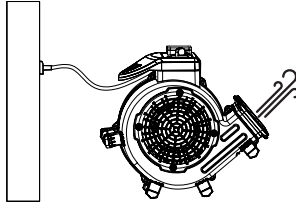

Stairs and Walls (45°)

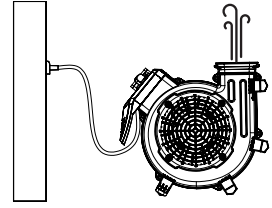

Ceilings (90°)

Power extension socket operation

Input voltage rating	220-240V~ 50Hz
Max Wattage from Motor	124W
Max Wattage from power extension socket	2100W

This floor dryer has a power extension feature which permits it to be coupled with other units or tools.

To operate the power extension feature, plug the first unit into a grounded electrical outlet. Then plug a second unit into the power extension socket of the first unit. A third unit can then be plugged into the power extension socket of the second unit, and subsequent units can be plugged in a similar manner.

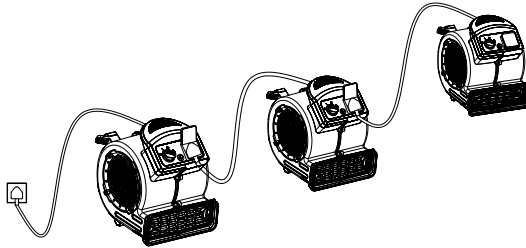

WARNING! Do not connect any tool or appliance with a power rating exceeding the maximum wattage specified above for the power extension socket.

Overload protection

The appliance is equipped with overload protection. When the appliance has activated the overload protection, operate the appliance as follows:

1. Wait until the floor dryer completely stops;
2. Remove and detach the other plugs from the power extension socket;
3. Press the reset button.

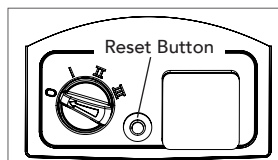

CARE AND CLEANING



IMPORTANT: Make sure that the tool has been thoroughly cleaned before storing it in a clean, dry and safe place, out of the reach of children.

Before storing the floor dryer, ensure the power switch is turned to the "0" (OFF) position, and unplug the unit from the power outlet. The power cord should be securely wrapped around the cord wraps on the handle. Always remove the plug from the power outlet before commencing any maintenance.

Never use chemical cleaners or an abrasive cloth to clean the floor dryer, use a mild detergent and warm water. Dry with a soft dry cloth. Do not oil the motor. Store in a dry place.

To conserve space while storing multiple units, this floor dryer can be stacked together with multiple additional units. To stack, the pegs on the intake grill on the power switch side of the unit must be inserted into the peg receiver on the opposite side of the partner unit.

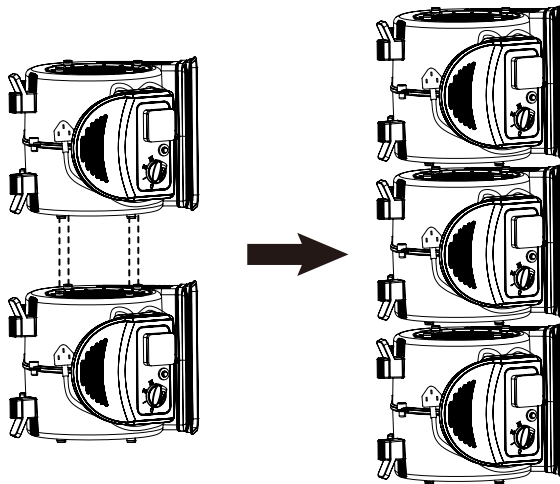

CAUTION: To prevent damage to floor dryer, property damage, or personal injury: Do not stack more than three units high. Stack only on a stable, level, even surface. Do not transport stacked units unless they are braced on all sides.



CAUTION: Do not turn on the floor dryer while it is stacked. The stacking pegs are for storage purposes only.

After each use

1. Inspect the plug and the cord to ensure that it has not been damaged during operation or between uses. If the plug or cord is damaged, do not use the floor dryer and replace the damaged part immediately.
2. Check the air intake and air discharge grills and make sure they are free of blockage.

TROUBLESHOOTING

Use this section to help you to try and solve any problems you may have:

PROBLEM	POSSIBLE CAUSES	REMEDIES
The floor dryer will not operate	Not connected to power supply	Connect to power supply
	Power cord or plug is defective	Have it checked by a specialist electrician
	Overload protection has engaged	First check and remove any tool or other devices from the power tool extension socket. Then set switch to the "0" (OFF) position and press the reset button.
Product does not reach full power	Extension cord not suitable for operation with this product	Do not use an extension cord
	Power source (e. g. generator) has too low voltage	Connect to another power source
	Air discharge grill are blocked	Clean the air discharge grill
The floor dryer runs but makes loud scraping noise	Damage to the unit has caused deformed housing or misaligned wheel	Contact a qualified electrician or the Customer Support service for assistance. Do not attempt to repair the appliance yourself.
The floor dryer runs but blower wheel does not rotate.	The blower wheel and housing are jammed.	Contact a qualified electrician or the Customer Support service for assistance. Do not attempt to repair the appliance yourself.
	There is a problem with the switch or capacitor.	Contact a qualified electrician or the Customer Support service for assistance. Do not attempt to repair the appliance yourself.
The floor dryer runs briefly then shuts off due to overload protection.	The intake grill or air discharge grill is obstructed	Contact a qualified electrician or the Customer Support service for assistance. Do not attempt to repair the appliance yourself.
	The motor is damaged or worn out	Contact a qualified electrician or the Customer Support service for assistance. Do not attempt to repair the appliance yourself.

NOTE: If you experience a problem with your appliance, please do not attempt to open or repair the appliance yourself. Doing so may void the warranty and could cause damage or personal injury. If the problem still persists, please contact us by referring to the service & support information on the following page.

DECLARATION OF CONFORMITY / PERFORMANCE



1. Product Models: AI019 (JNC2-P)
2. Product Description: Wessex High Speed Fan / Dryer / Air Mover
3. Name and Address of the Manufacturer (or its authorised representative in the UK): Toolstation - company number 04372131.
4. This declaration of conformity is issued under the sole responsibility of Toolstation.
5. The object of the declaration described above is in conformity with the relevant Union harmonisation legislation:
 - The Electrical Equipment (Safety) Regulations 2016 (2014/35/EU)
 - Electromagnetic Compatibility Regulations 2016 (2014/30/EU)
 - The Restriction of the Use of Certain Hazardous Substances in Electrical and Electronic Equipment Regulations 2012 (2011/65/EU&(EU)2015/863)
6. References to the relevant standards used or references to the specifications in relation to which conformity is declared:

EN 60335-1
EN 60335-2-80
EN 62233
EN IEC 55014-1
EN IEC 55014-2
EN IEC 61000-3-2
EN 61000-3-3

Signed for and on behalf of Toolstation - company number 04372131.

ENVIRONMENTAL INFORMATION



The symbol on the product or its packaging indicates that this product must not be disposed of with your other household waste. Instead, it is your responsibility to dispose of your waste equipment by handing it over to a designated collection point for the recycling of waste electrical and electronic equipment. The separate collection and recycling of your waste equipment at the time of disposal will help conserve natural resources and ensure that it is recycled in a manner that protects human health and the environment. For more information about where you can drop off your waste for recycling, please contact your local authority, or where you purchased your product.

WARRANTY

Toolstation products deliver reliable service for normal, household use in domestic settings. All Toolstation products are individually tested before leaving the factory. If you are a consumer and you experience a problem with your Toolstation product, which is found to be defective due to faulty materials or workmanship within the Warranty Period, this Toolstation Warranty will cover repair or - at the discretion of Toolstation – replacement with a functionally equivalent Toolstation product. Your product is under warranty for 1 year from the date of purchase or the date of delivery of the product, if later.

The warranty is subject to the following provisions:

- The warranty does not cover accidental damage, misuse, parts, knobs, or consumable items.
- The product must be correctly installed and operated in accordance with the instructions contained in this manual.
- It must be used solely for domestic purpose.
- The warranty will be rendered invalid if the product is re-sold or has been damaged by inexpert repair.
- Specifications are subject to change without notice.
- The manufacturer disclaims any liability for incidental or consequential damages.
- The warranty is in addition to, and does not diminish your statutory or legal rights.

CUSTOMER SUPPORT

www.coreservice.co.uk

Call us +44 01904 947568

Email: support@coreservice.co.uk

Made in China

Imported by Toolstation 04372131.

Wessex Electrical is a Toolstation brand. Toolstation is part of Travis Perkins Trading Company Limited.